

**HEAVY DUTY (H.D.) COUPLER**

NO SCALE

NOTES

1. BOLTS TO BE A-36 1 1/2" DIAMETER.
2. BOLTS, NUTS, WASHERS AND SLEEVES TO BE ZINC PLATED.
3. WASHERS TO BE 3 1/2" O.D. X 7 GAUGE.
4. SHIP WITH NUTS AND WASHERS PLACED ON BOLTS.

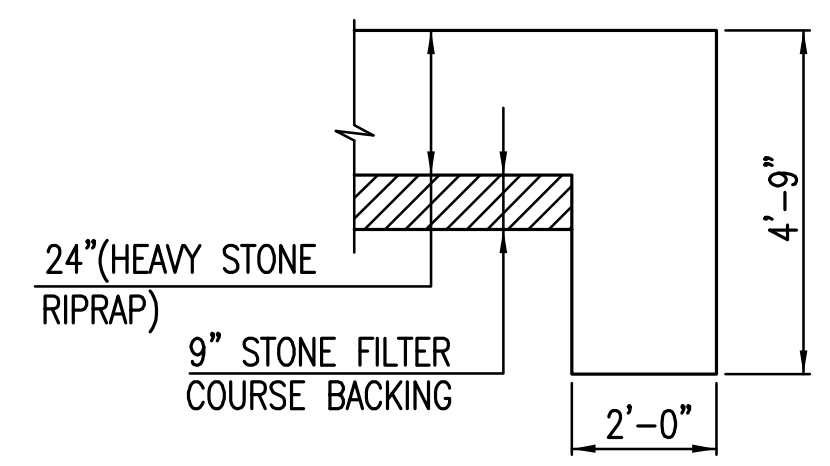

**TYPICAL SECTION THRU TOEWALL**

NO SCALE

NOTES

1. ALL RIPRAP FOR THIS PROJECT SHALL BE NATURAL STONE. NEITHER BROKEN CONCRETE, FABRIC ENVELOPE, NOR PREMIXED DRY PACKAGED CONCRETE BAG ALTERNATES WILL BE ALLOWED, UNLESS INDICATED OTHERWISE.
2. TOEWALLS SHALL BE INSTALLED ALONG ALL UNPROTECTED EDGES OF STONE RIPRAP.
3. GROUTING OF THE SURFACE OF THE RIPRAP SHALL NOT BE PERFORMED, UNLESS INDICATED OTHERWISE. GROUTING OF THE TOEWALLS SHALL BE PERFORMED PER CITY SPECIFICATIONS.

**HEAVY STONE RIPRAP DETAILS**

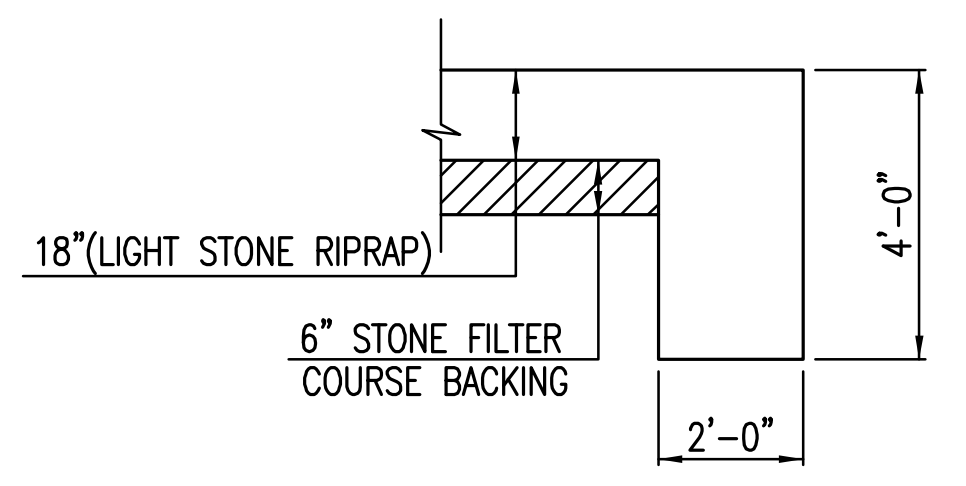

**TYPICAL SECTION THRU TOEWALL**

NO SCALE

NOTES

1. ALL RIPRAP FOR THIS PROJECT SHALL BE NATURAL STONE. NEITHER BROKEN CONCRETE, FABRIC ENVELOPE, NOR PREMIXED DRY PACKAGED CONCRETE BAG ALTERNATES WILL BE ALLOWED, UNLESS INDICATED OTHERWISE.
2. TOEWALLS SHALL BE INSTALLED ALONG ALL UNPROTECTED EDGES OF STONE RIPRAP.
3. GROUTING OF THE SURFACE OF THE RIPRAP SHALL NOT BE PERFORMED, UNLESS INDICATED OTHERWISE. GROUTING OF THE TOEWALLS SHALL BE PERFORMED PER CITY SPECIFICATIONS.

**LIGHT STONE RIPRAP DETAILS**

Saved 08-31-2011 9:31:54 AM by MASON  
 Plot Scale: 1:1 09-06-2011 4:10:38 PM by JEBRA, MASON  
 J:\Civil\06201\dwg\Sws\Third Add\06201\_D05

J:\Civil\06201\dwg\Sws\Third Add\06201\_D05.dwg



<b>MISCELLANEOUS DETAILS (STORM SEWER)</b>			
CITY ENGINEER <b>JAMES L. ARMOUR, P.E., L.S.</b>			
PROJECT NUMBER <b>468-84771</b>	OCA NUMBER <b>751504</b>	DATE <b>11/2010</b>	
CITY ENGINEER'S OFFICE CITY HALL - SEVENTH FLOOR 455 NORTH MAIN STREET WICHITA, KANSAS 67202-1620 (316) 268-4501		DESIGN	DRAWN
		SHEET <b>6 of 25</b>	