



Cook, Flatt & Strobel  
ENGINEERS, P.A.  
CFS

CFS PROJECT NO:  
10-5048

CITY OF WICHITA, KANSAS  
E. HARRY ST. & WOODLAWN ST.  
INTERSECTION  
DATE: 08-01-11 DESIGNED BY: KWB DRAWN BY: JR CHECKED BY: KKH

SHEET TITLE:  
SIGNAL  
WIRING  
PLAN

PROJECT NUMBER  
87N-0494-01

FINAL  
PLANS

SHEET NUMBER:  
49 of 69

SYMBOLS

- 1 - Junction Box Number
- 2 - Service Box Number
- B - Sign Letter
- 27 - Signal Head Number
- P03 - Pedestrian Head Number
- 5 - Detection Zone

- LEGEND
- A POWER LEAD IN WIRE 6 AWG 3-1C
  - B THRU TRAFFIC SIGNAL CABLE 14 AWG 7C
  - C LT. TURN TRAFFIC SIGNAL CABLE 14 AWG 7C
  - D PEDESTRIAN SIGNAL CABLE 14 AWG 7C
  - E NOT IN USE
  - F VIDEO COMM./POWER CABLE
  - G GROUND 8 AWG 1C
  - H RT. TURN TRAFFIC SIGNAL CABLE 14 AWG 7C

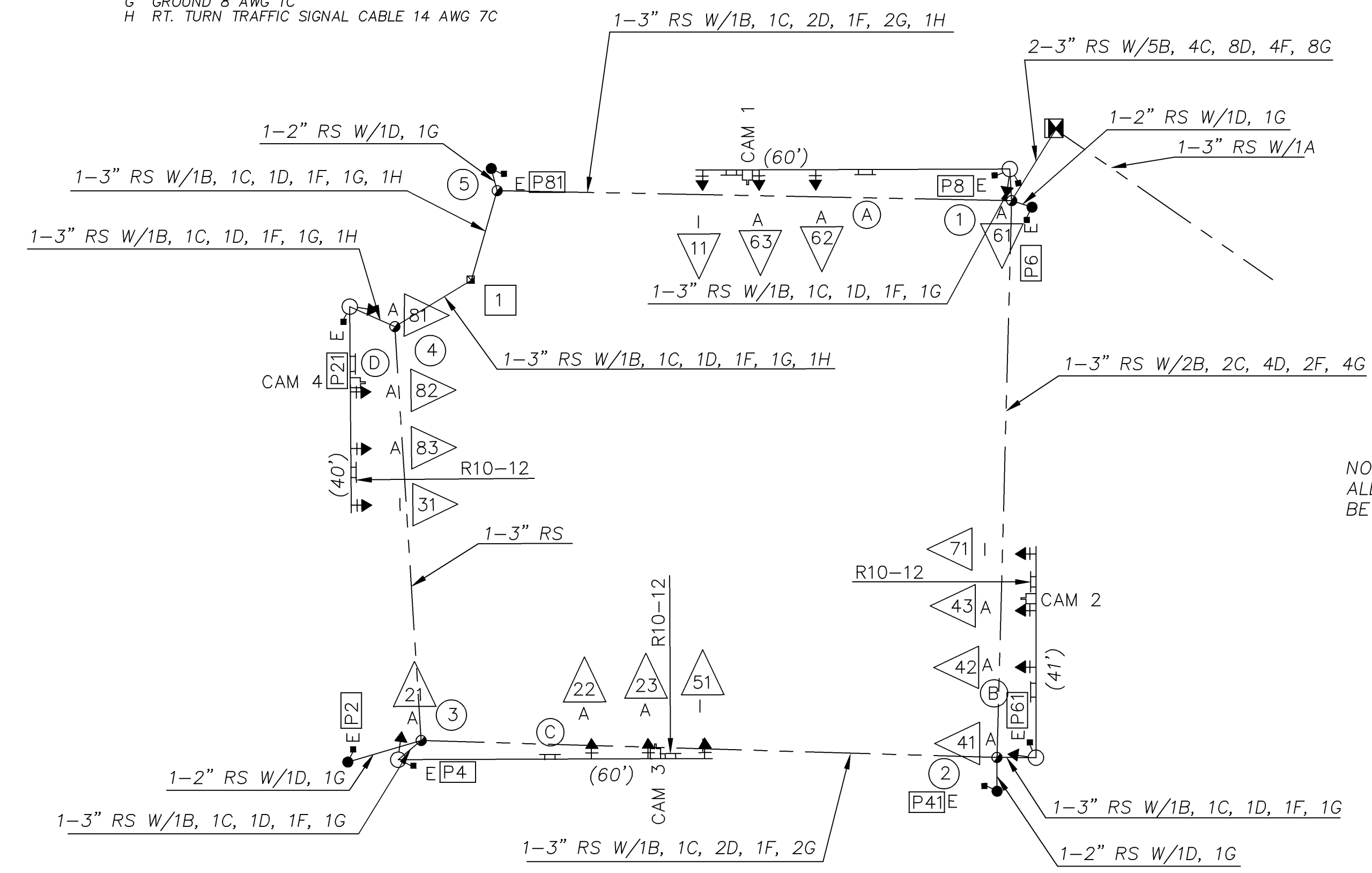

NOTE:  
ALL CONDUIT TO  
BE RIGID STEEL.

WIRING DIAGRAM

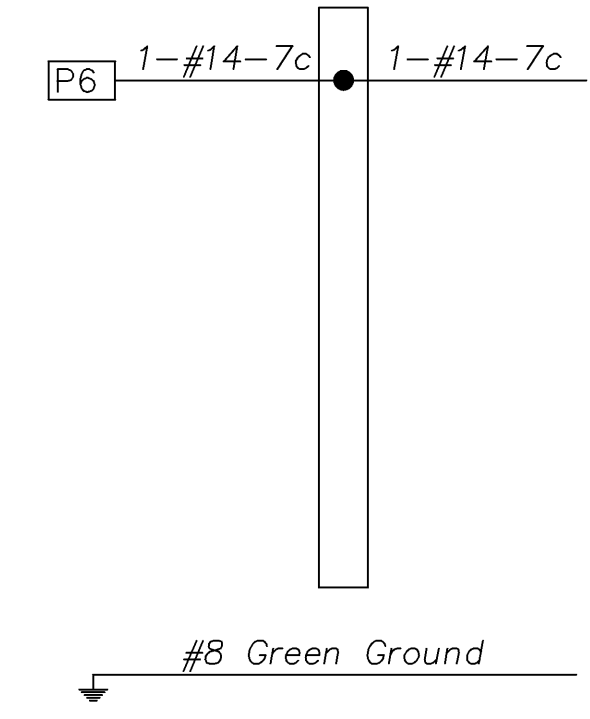

PEDESTRIAN POLE 1

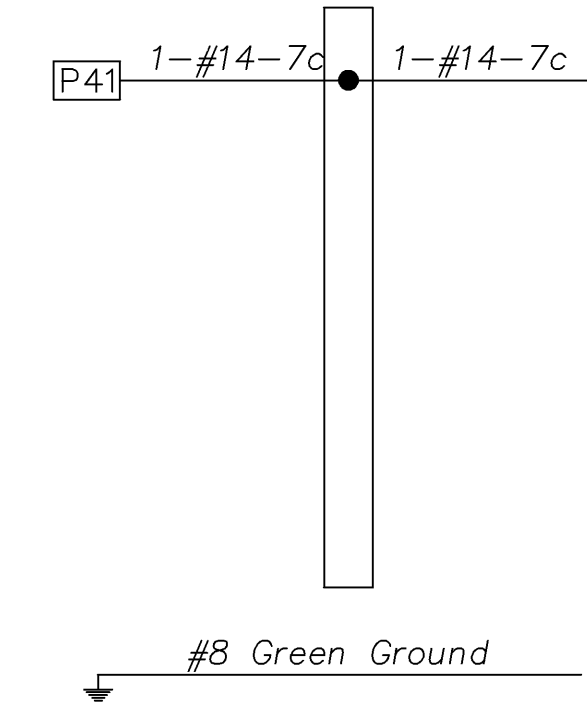

PEDESTRIAN POLE 2

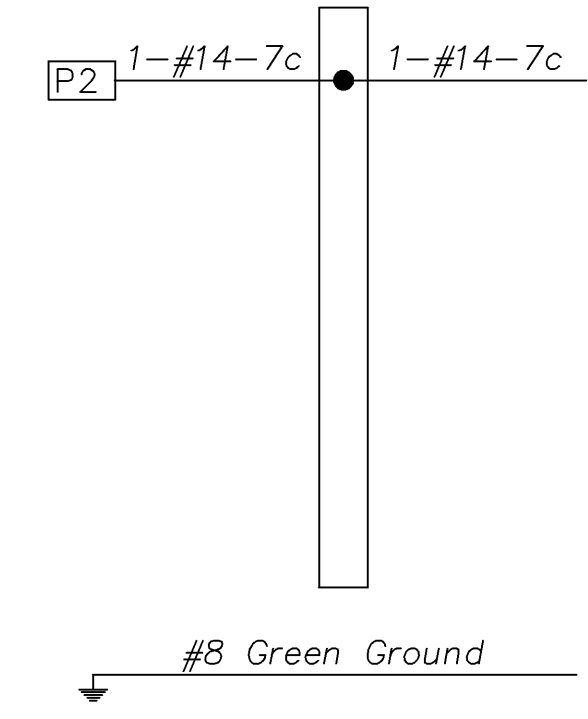

PEDESTRIAN POLE 3

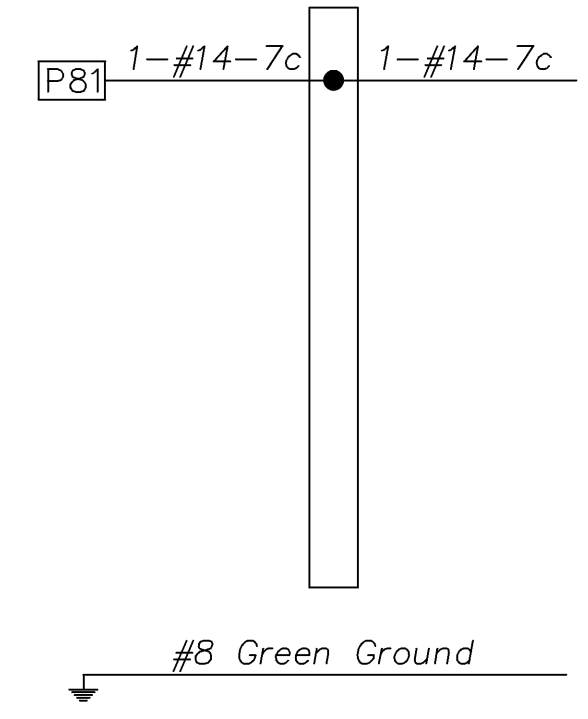

PEDESTRIAN POLE 4

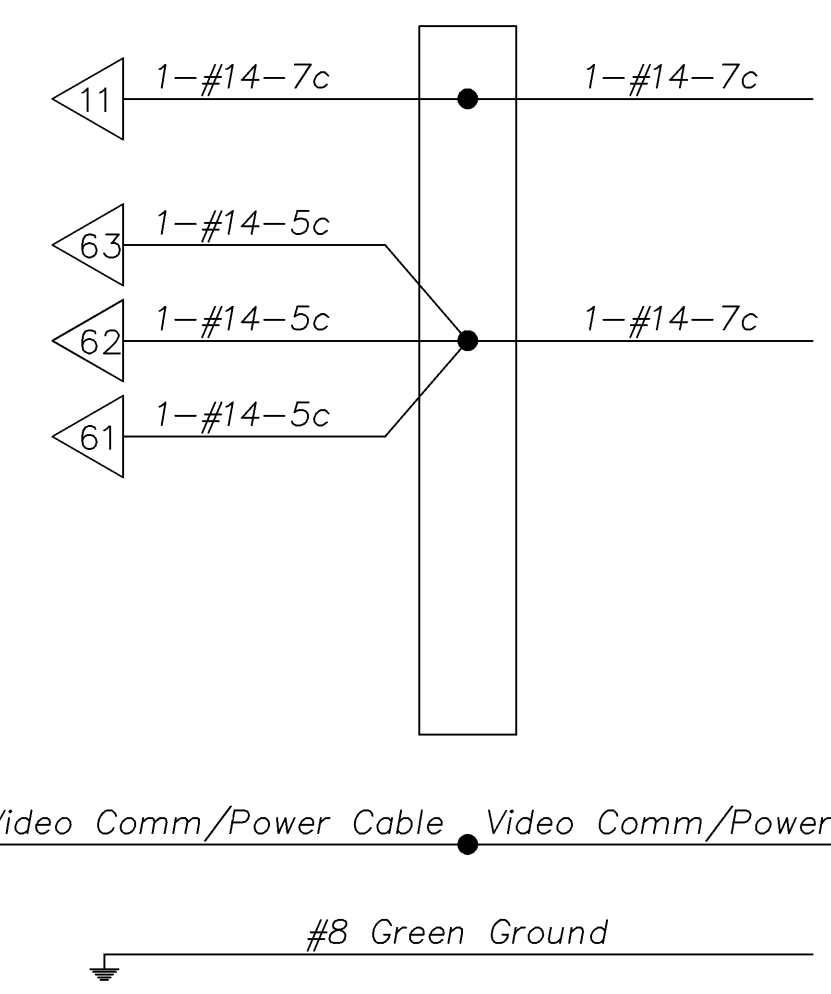

SIGNAL POLE 1

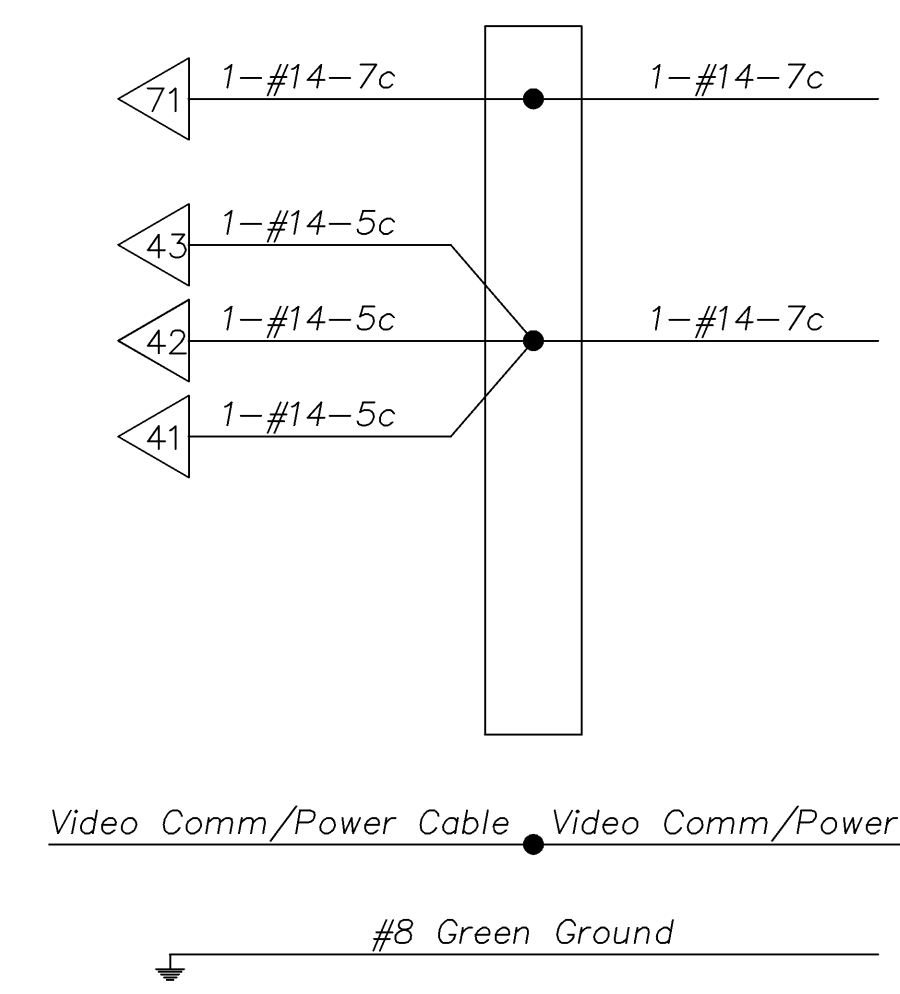

SIGNAL POLE 2

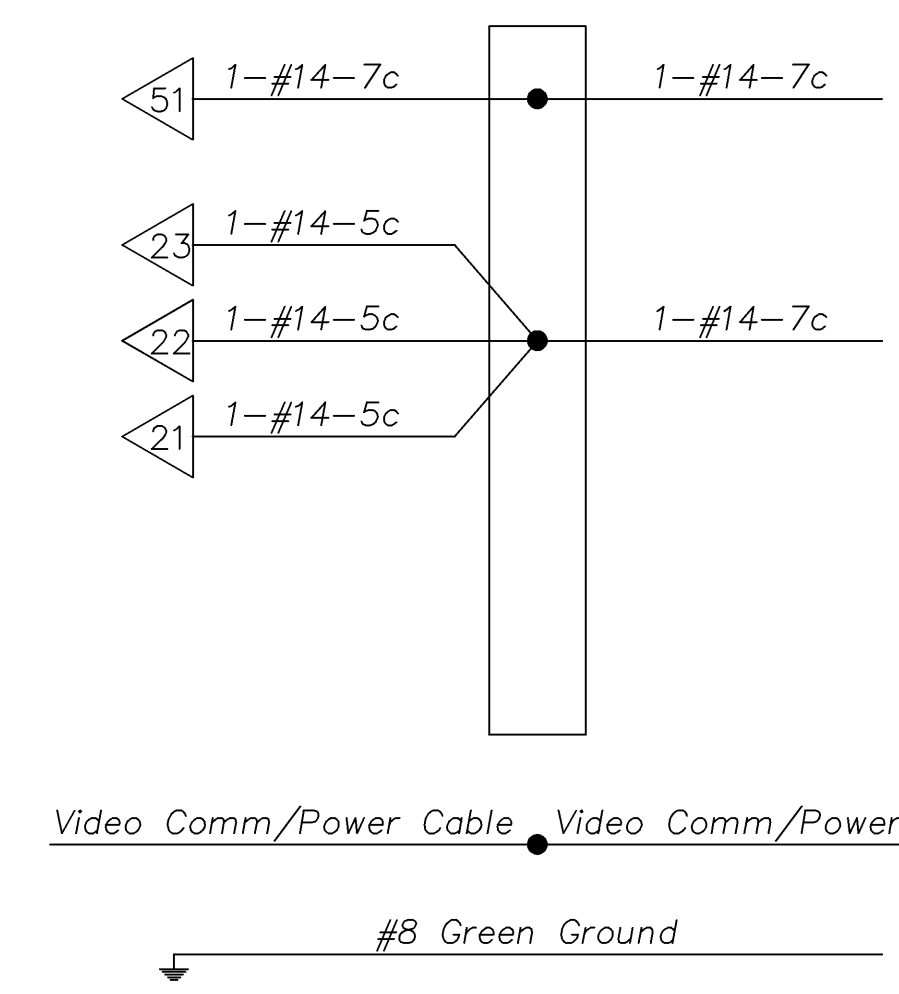

SIGNAL POLE 3

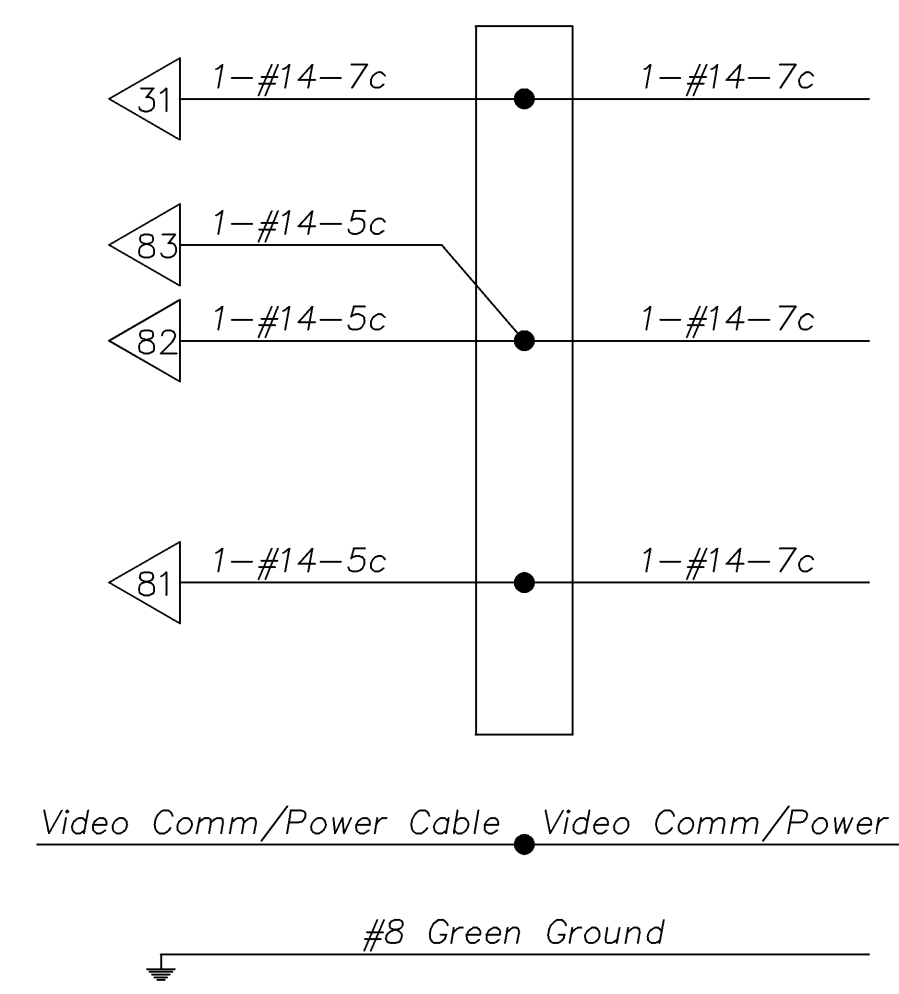

SIGNAL POLE 4

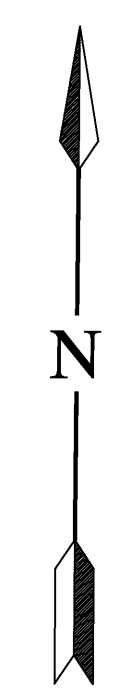

J:\2011\87N-0494\87N-0494-01\87N-0494-01-11-01.dwg, INT. DETAIL, 08/01/11 4:26:17 PM