

**CONCRETE FULL RADIUS DRIVES
(RESIDENTIAL DRIVES)**

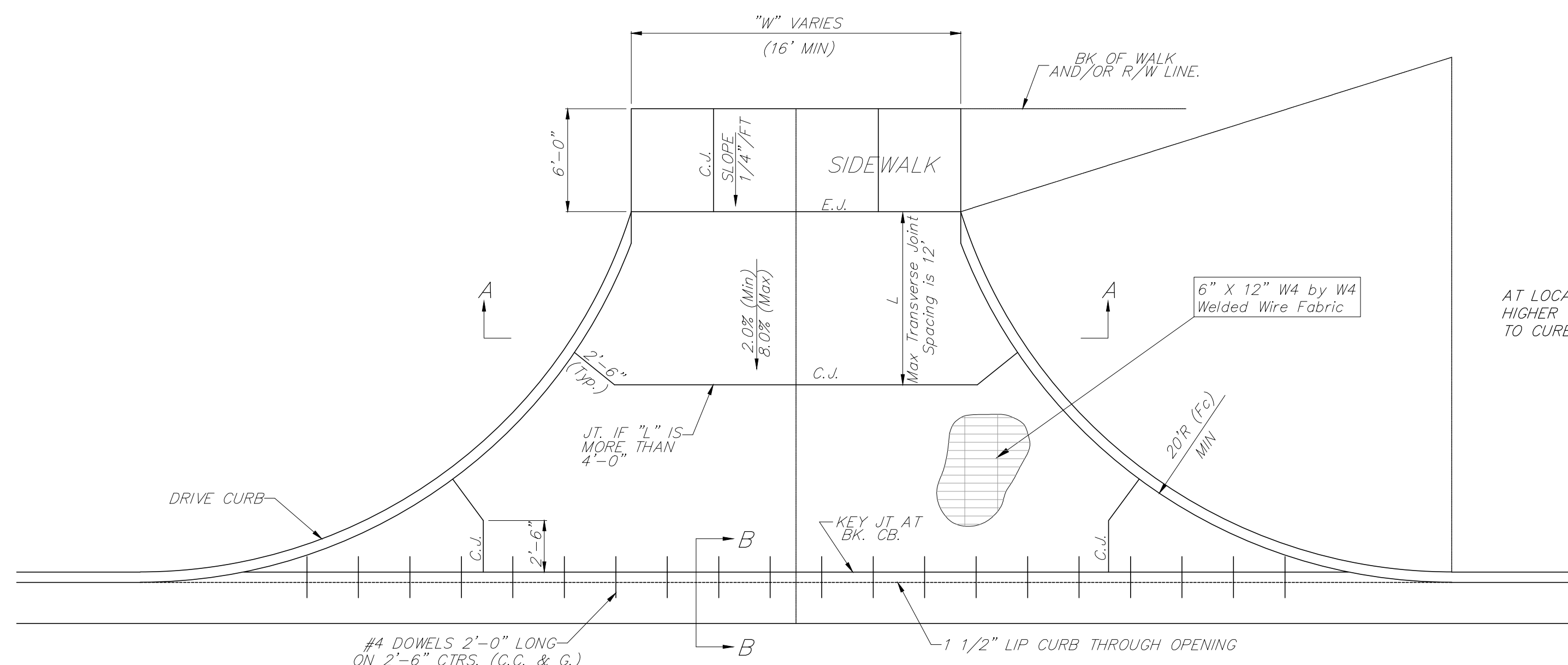

**CONCRETE PARTIAL RADIUS DRIVES
(COMMERCIAL DRIVES)**

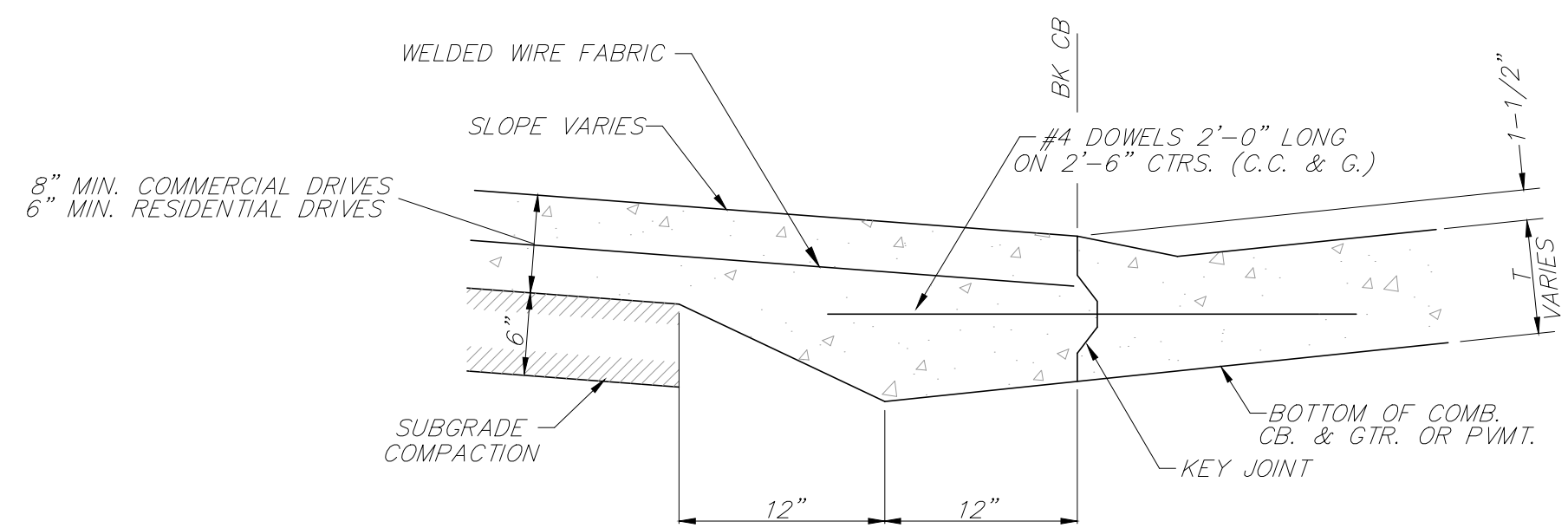

**BACK OF CURB DETAIL
SECTION B-B
(NO SCALE)**

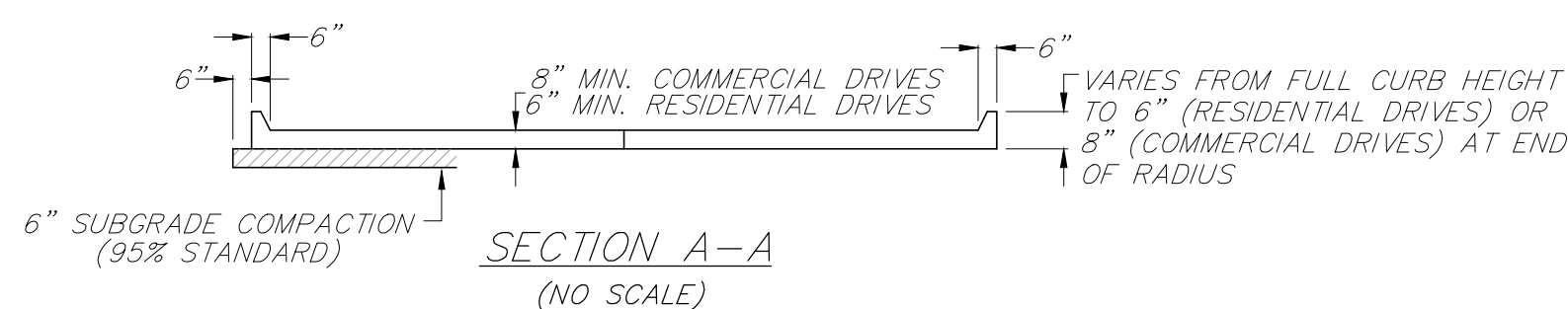

**SECTION A-A
(NO SCALE)**

GENERAL NOTES

1. CONCRETE DRIVEWAY CONSTRUCTION DETAILED ON THIS SHEET IS FOR USE WITH FULL HEIGHT STREET CURBS.
2. ONE LONGITUDINAL JOINT SHALL BE CONSTRUCTED ALONG THE CENTERLINE OF CONCRETE DRIVES HAVING A "W" DIMENSION OF 24' OR LESS. TWO LONGITUDINAL JOINTS SHALL BE CONSTRUCTED WITH EQUAL SPACINGS NOT TO EXCEED 10' FOR CONCRETE DRIVES WITH A "W" DIMENSION GREATER THAN 24'.
3. JOINT SPACING IN THE DRIVEWAY WALK SECTION SHALL BE A MINIMUM OF 3' AND A MAXIMUM OF 6' AND ARE TO BE EQUALLY SPACED WITHIN THIS RANGE. WALK SECTION SHALL BE CONSTRUCTED TO THE SAME THICKNESS AS THE DRIVEWAY.
4. DOWEL BARS SHALL BE OMITTED FROM THE KEYED CONSTRUCTION JOINT ALONG THE BACK OF THE STREET CURB LINE WHEN DRIVEWAYS ARE CONSTRUCTED IN CONJUNCTION WITH NEW CONCRETE PAVEMENT CONSTRUCTION.
5. ADDITIONAL THICKNESS OF DRIVE AS INDICATED IN THE DRAWINGS WILL NOT BE PAID FOR DIRECTLY AND THIS COST SHALL BE INCLUDED IN THE UNIT PRICE BID FOR THE DRIVEWAY CONSTRUCTION.
6. ONE HALF INCH EXPANSION JOINTS SHALL ALSO BE INSTALLED ALONG THE PROPERTY LINE AND/OR BACK OF WALK LINE WHEN DRIVE CONSTRUCTION ALONG THIS LINE ABUTS CONCRETE PARKING LOTS OR CONCRETE DRIVE EXTENSION.
7. ALL CONCRETE RESIDENTIAL DRIVEWAYS SHALL BE A MINIMUM OF 8" IN THICKNESS AND SHALL BE WITH REINFORCEMENT.
8. ALL CONCRETE COMMERCIAL DRIVEWAYS SHALL BE A MINIMUM OF 8" IN THICKNESS AND SHALL BE WITH REINFORCEMENT. DRIVEWAYS MAY BE CONSTRUCTED THICKER THAN 8" WITH 6"x12" W4-W4 WELDED WIRE FABRIC WHEN PROPERLY AUTHORIZED BY THE PROPERTY OWNER WITH THE ENGINEERS CONCURRENCE. NO EXTRA PAYMENT WILL BE MADE FOR DRIVEWAYS THICKER THAN 8".
9. COMPACTION OF SUBGRADE BENEATH PROPOSED DRIVES SHALL NOT BE PAID FOR DIRECTLY, BUT SHALL BE INCLUDED IN THE UNIT PRICE FOR THE BID ITEM REIN. CONC. DRIVE PVMT.

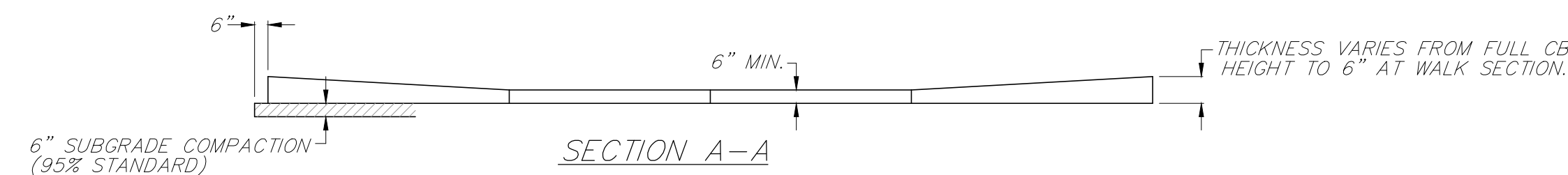
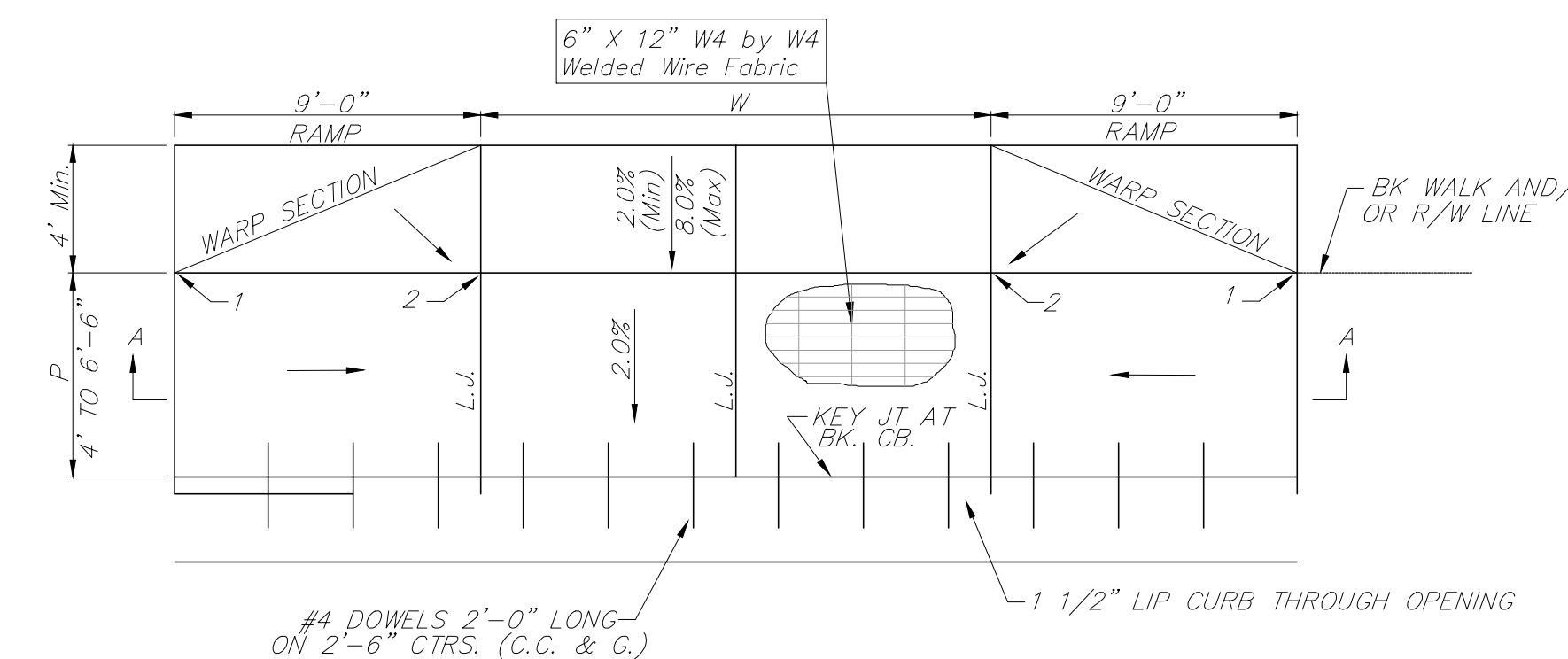

| PARKING WIDTH "P" | 4' | 4.5' | 5' | 5.5' | 6' | 6.5' |
|--|-------|-------|-------|-------|-------|-------|
| DIST. OF PT "1" ABOVE TOP OF FULL CURB | 0.08' | 0.09' | 0.10' | 0.11' | 0.12' | 0.13' |
| DIST. OF PT "2" BELOW TOP OF FULL CURB | -.30' | -.29' | -.28' | -.27' | -.26' | -.25' |

FULL RAMP DRIVE (P = 4.0' TO 6.5')