

TYPICAL 35' B-B PAVEMENT DETAILS

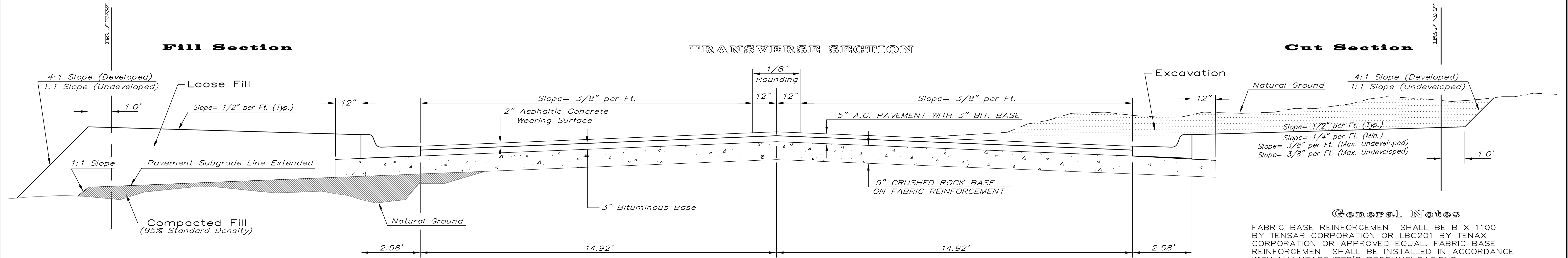

General Notes
 FABRIC BASE REINFORCEMENT SHALL BE B X 1100 BY TENSAR CORPORATION OR LBO201 BY TENAX CORPORATION OR APPROVED EQUAL. FABRIC BASE REINFORCEMENT SHALL BE INSTALLED IN ACCORDANCE WITH MANUFACTURER'S RECOMMENDATIONS.

ROCK BASE IS TO BE COMPACTED AND SMOOTHED WITH A STEEL FACED ROLLER PRIOR TO PLACEMENT OF ASPHALT. TACK COAT WILL NOT BE APPLIED TO ROCK BASE.

A TACK COAT OF EMULSIFIED ASPHALT (SC-1H OR CSS-1H) SHALL BE APPLIED AT AN APPROXIMATE RATE OF 0.05 GALLONS PER SQUARE YARD BETWEEN EACH LIFT OF ASPHALTIC MATERIAL.

BITUMINOUS BASE AND ASPHALTIC CONCRETE WEARING SURFACE SHALL BE PLACED WITH A LAYDOWN MACHINE HAVING AUTOMATIC CONTROLS FOR LINE AND GRADE.

CONSTRUCTION JOINTS IN EACH LIFT SHALL BE STAGGERED A MINIMUM DISTANCE OF ONE (1) FOOT FROM JOINTS IN PRECEDING LIFTS AND PLACED SO THAT A JOINT WILL BE CONSTRUCTED ON THE CENTERLINE OF THE TOP LIFT.

THE ASPHALTIC CONCRETE PAVEMENT BETWEEN THE COMBINED CURB AND GUTTER SHALL BE PAID AS SQUARE YARDS OF 5\"/>

CRUSHED ROCK GRADATION REQUIREMENTS
 PERCENT OF AGGREGATE RETAINED

2-1/2"	0
3/4"	20 - 60
#4	50 - 80
#40	80 - 94
#200	90 - 98

ROCK QUALITY SHALL CONFORM TO THE REQUIREMENTS SPECIFIED BY THE KDOT 1990 EDITION STANDARD SPECIFICATION SUBSECTION 1102 FOR DURABILITY CLASS I.

* UNDERDRAIN AGGREGATE
 Percent of Aggregate Retained

1"	0
3/4"	0 to 10
3/8"	45 to 80
#4	90 to 100
#8	95 to 100

NOTE: Place 4" PVC Perforated Pipe at all drainage sump locations.
 Cost of Underdrain System to be Incidental to the Reinforced Crushed Rock Subgrade.
 Inlet Type May Vary From That Shown.

Rock Quality Shall Conform To The Requirements Specified By K.D.O.T. 1990 Edition Standard Specification Subsection 1102 For Durability Class I.

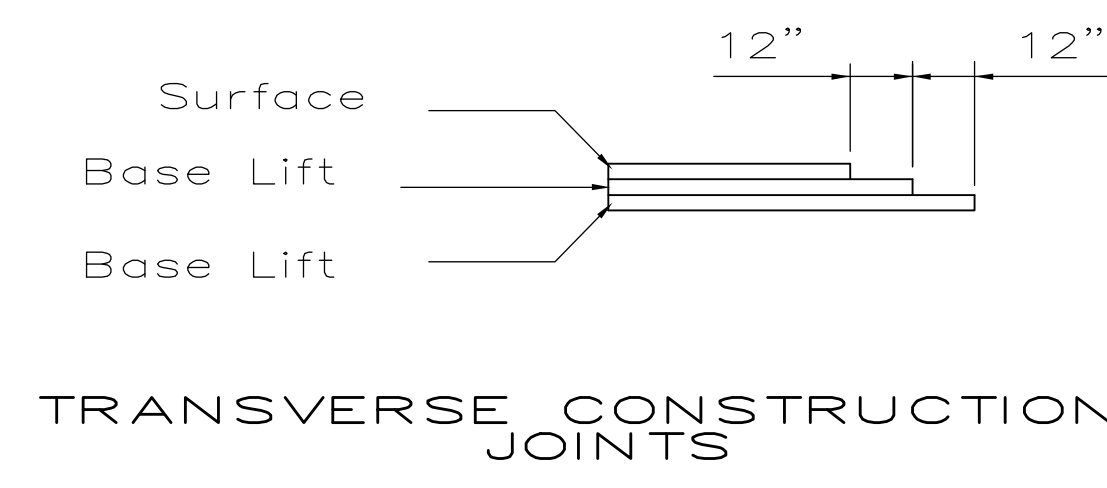

Transverse construction joints shall be constructed in flexible base pavements at locations where pavement joints existing flexible base pavement as shown by the detail. All costs associated with the construction of the transverse joint shall be included in the bid price for Square Yards 5\"/>

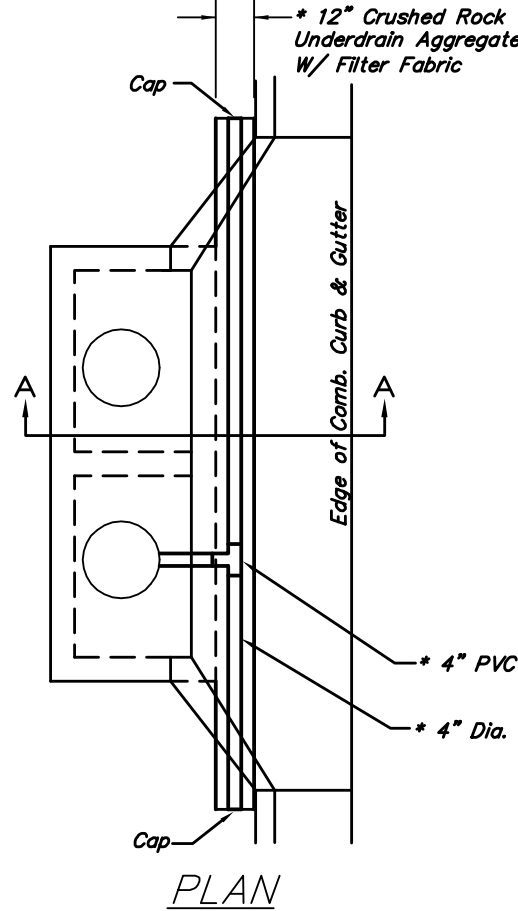

PAVEMENT UNDERDRAIN DETAIL
 NOT TO SCALE

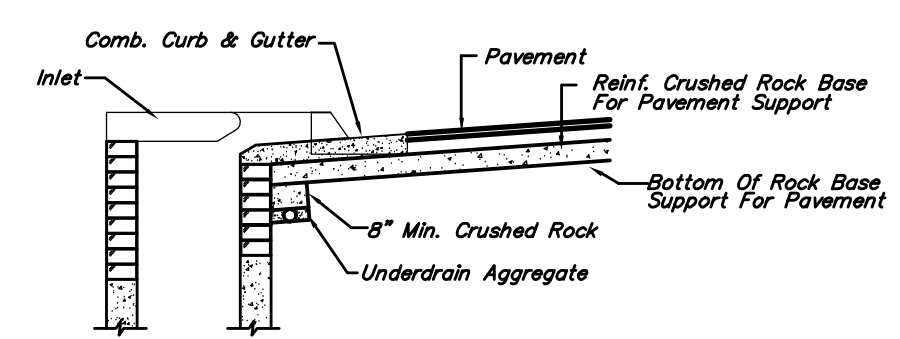

(Min. 16 Perforations Per Lin. Ft. @ 1/4" Dia.)
 Perforations To Be on Bottom Half

SECTION A-A

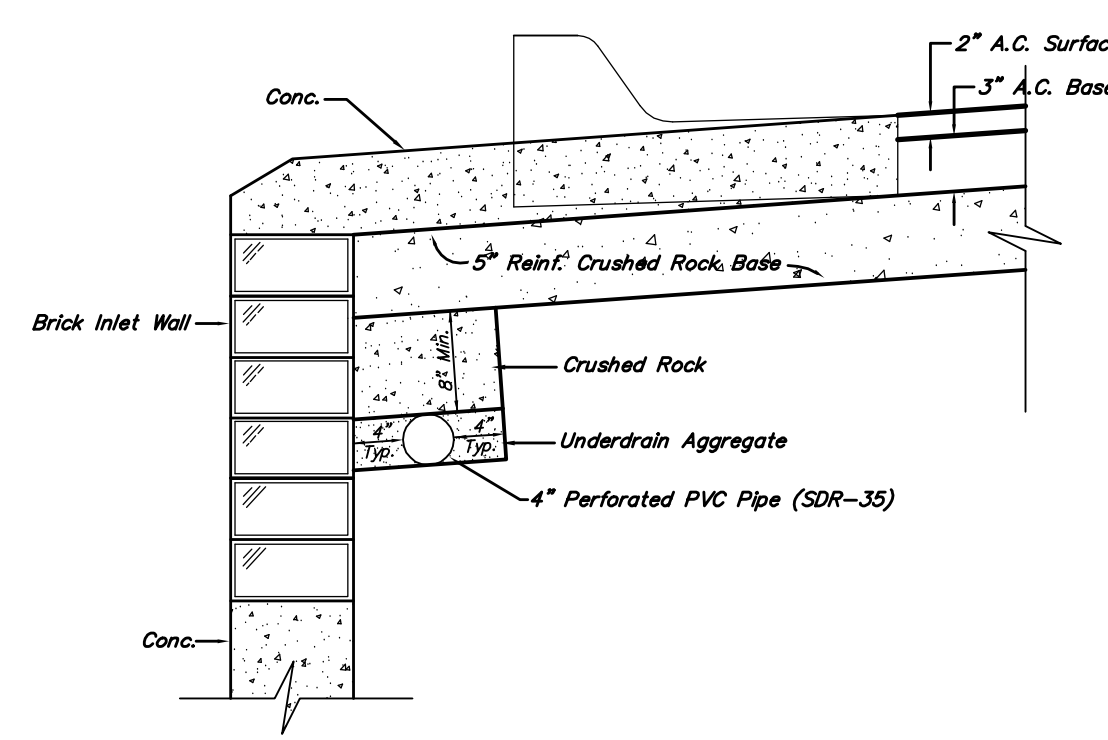

TRENCH DRAIN DETAIL FOR RES. STREETS
 NOT TO SCALE

	35' B-B Pavement Detail 5" AC Pavement with 5" Reinf. Rock Base City of Wichita, KS	
	Baughman Company, P.A. 515 Ellis St. Wichita, KS 67211 P 316-2637271 F 316-2634149 ENGINEERING SURVEYING PLANNING LANDSCAPE ARCHITECTURE	
PROJECT NUMBER	DESIGN C.O.W.	DRAWN STAFF
REVISIONS:	APPROVED	DATE 07/12
SCALE NONE	SHEET 2 OF 35	