

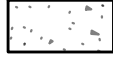





LEGEND

-  4" Concrete Sidewalk
-  Brick Pavers
-  Curb & Gutter
-  8" Concrete Pavement on a 7" Crushed Rock Base, Reinforced
-  9" Concrete Pavement on a 6" Crushed Rock Base, Reinforced
-  Flow Path for Drainage

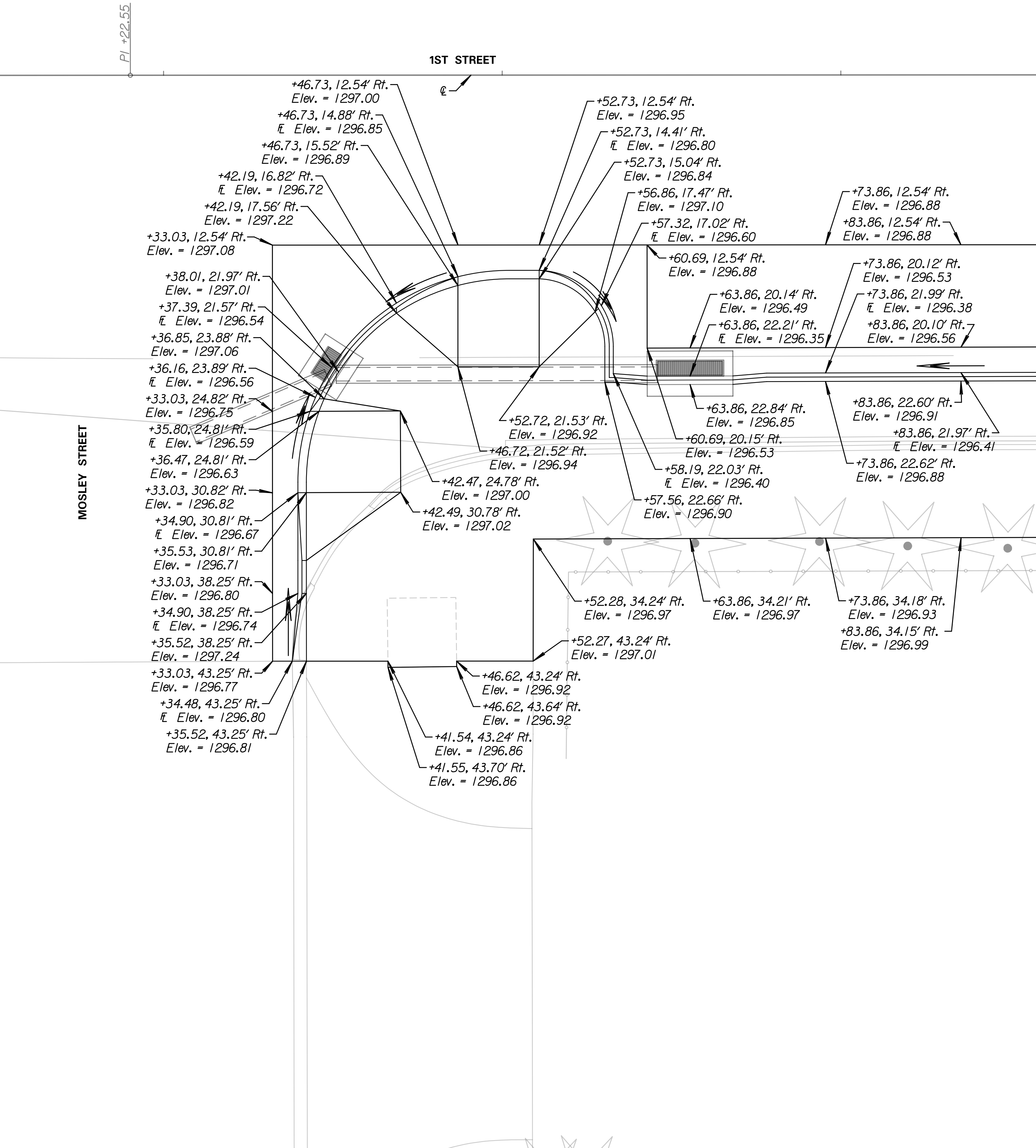
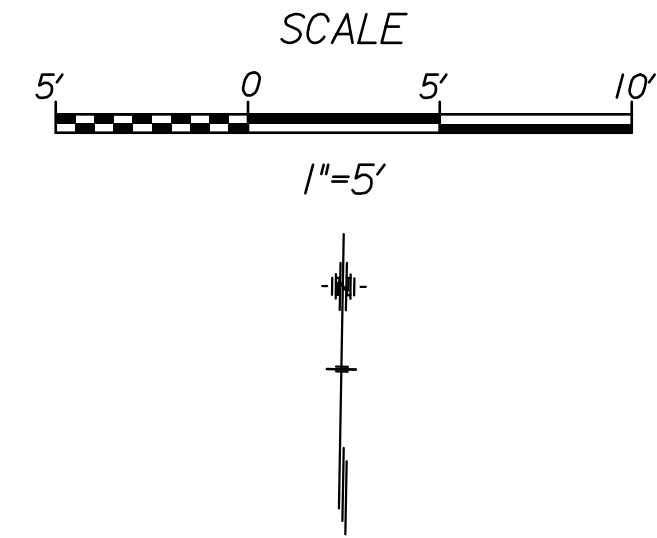
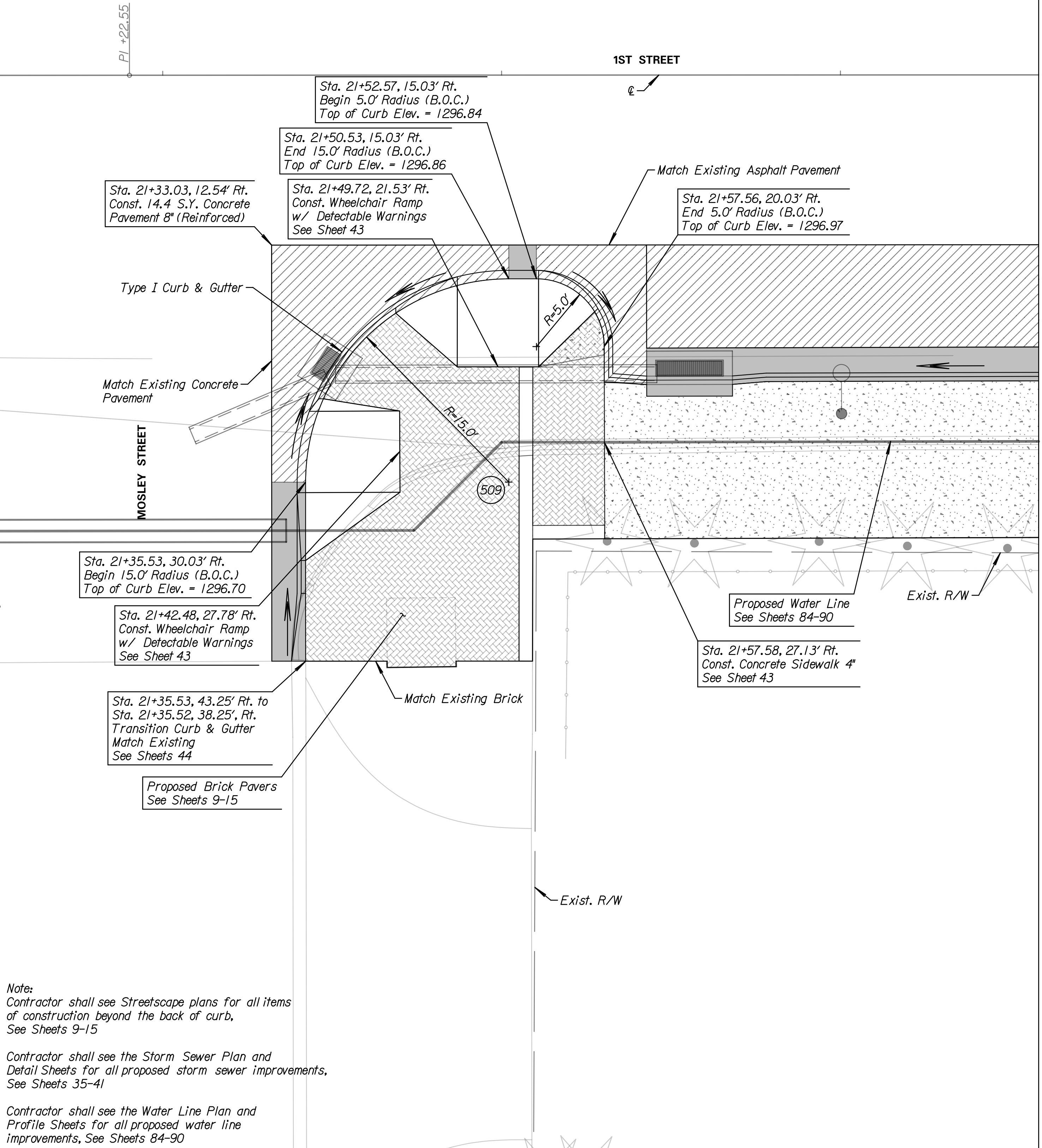

Tran Systems

245 NORTH WACO
SUITE 222
WICHITA, KANSAS 67202
PHONE: 316-303-3000
FAX: 316-303-0166

CONSULTANTS:

LK ARCHITECTURE, INC.

345 RIVERVIEW
SUITE 200
WICHITA, KANSAS 67208
PHONE: 316-268-0230

1ST STREET IMPROVEMENTS
SANTA FE TO WASHINGTON IN OLD TOWN
WICHITA, KANSAS
CITY OF WICHITA

REVISIONS:	MARK	DATE	DESCRIPTION

PROJ NO: 472-85285
SCALE: 1"=5'
DATE: 7/5/2017
DESIGNED BY: TAU
DRAWN BY: TAU
CHECKED BY: MDB

SHEET TITLE:
**S.E. QUADRANT
DETAIL LAYOUT
1ST STREET &
MOSLEY STREET**

SHEET NO.
29
SHEET 29 OF 90

taumhd 7/5/2017 3:55:59 PM c:\tran\systems\proj\taumhd\48273\CLAY\M01-110.dgn