

NOTE:

- ALL METAL TO BE POWDER COATED. COLOR: RAL TEXTURED NUTMEG
- SURFACE MOUNT BENCH. EXTEND ANCHORS THROUGH PAVERS INTO CONC. BASE.
- ALL HARDWARE TO BE 18-8 SS
- PROVIDE SAMPLES OF ACRYLIC PANEL FOR REVIEW.
- PROVIDE SAMPLES OF WOOD SEAT FOR REVIEW.
- PROVIDE SAMPLES OF POWDERCOATING FOR REVIEW.

# 15 LIGHTED BENCH - PERSPECTIVE

- ALL DETAIL OF LIGHTED BENCH ARE SUPPLEMENTAL TO THE LIGHTED BENCH SPECIFICATIONS.
- PROVIDE SHOP DRAWINGS OF LIGHTED BENCH FOR REVIEW.
- LIGHTED BENCH TO BE LANDSCAPE FORMS BACKLESS BENCH (SF2622-001), OR ARCHITECT APPROVED EQUIVALENT.

1-1/2" = 1'-0"

### BENCH NOTE:

- ALL METAL TO BE POWDER COATED. COLOR: RAL TEXTURED NUTMEG
- SURFACE MOUNT BENCH. EXTEND ANCHORS THROUGH PAVERS INTO CONC. BASE
- ALL HARDWARE TO BE 18-8 SS
- PROVIDE SAMPLES OF ACRYLIC PANEL FOR REVIEW.
- PROVIDE SAMPLES OF WOOD SEAT FOR REVIEW.
- PROVIDE SAMPLES OF POWDERCOATING FOR REVIEW.

### LIGHTING NOTE:

- MANUFACTURER TO INSTALL LED LIGHTING WITHIN BENCH.
- COORDINATE STUB UP OF POWER SUPPLY W/ ELECT. CONTRACTOR.
- LOCATE STUB UP FOR POWER IN THE MIDPOINT OF THE BENCH BASE. SEE PLAN FOR BENCH LOCATIONS.

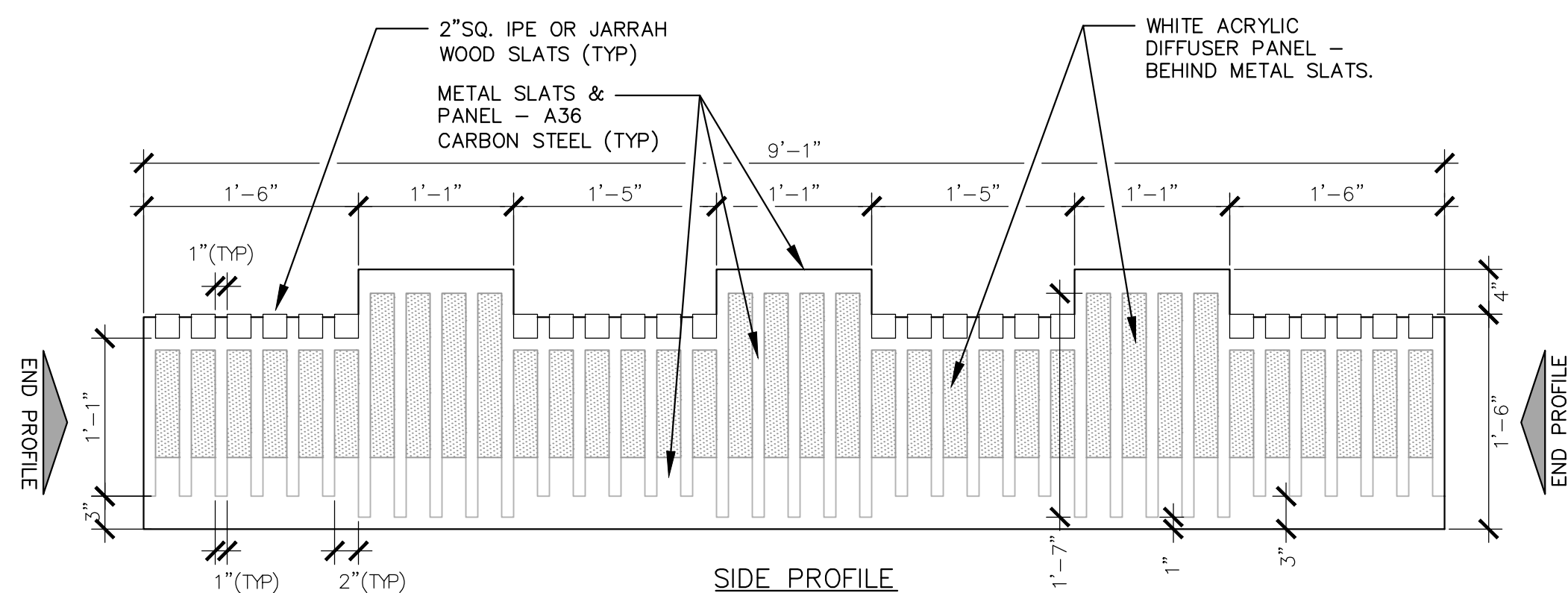
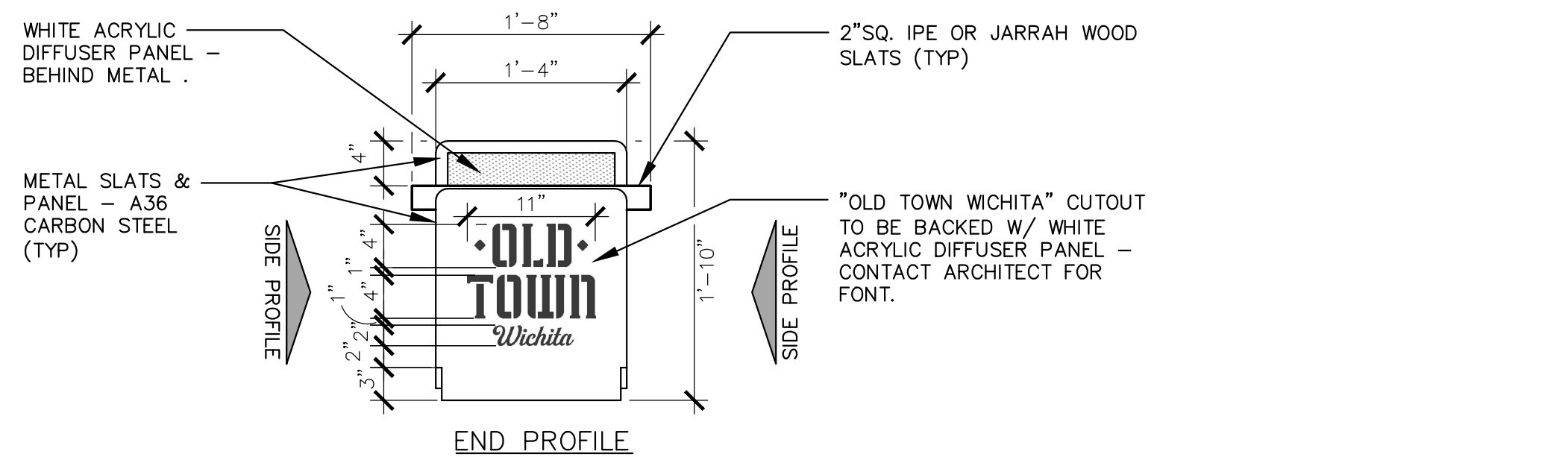

# 16 LIGHTED BENCH - PROFILES

- ALL DETAILS OF LIGHTED BENCH ARE SUPPLEMENTAL TO THE LIGHTED BENCH SPECIFICATIONS.
- PROVIDE SHOP DRAWINGS OF LIGHTED BENCH FOR REVIEW.
- LIGHTED BENCH TO BE LANDSCAPE FORMS BACKLESS BENCH (SF2622-001), OR ARCHITECT APPROVED EQUIVALENT.

1" = 1'-0"

# 17 LIGHTED BENCH - MOUNTING

- ALL DETAILS OF LIGHTED BENCH ARE SUPPLEMENTAL TO THE LIGHTED BENCH SPECIFICATIONS.
- PROVIDE SHOP DRAWINGS OF LIGHTED BENCH FOR REVIEW.
- LIGHTED BENCH TO BE LANDSCAPE FORMS BACKLESS BENCH (SF2622-001), OR ARCHITECT APPROVED EQUIVALENT.

1-1/2" = 1'-0"

NOTE:

- COORDINATE ANCHOR SPECIFICATION W/ MANUFACTURE & ARCHITECT.
- TOTAL OF EIGHT MOUNTS PER BENCH.
- ALL MOUNTING HARDWARE USED ON LIGHTED BENCH TO BE SS.

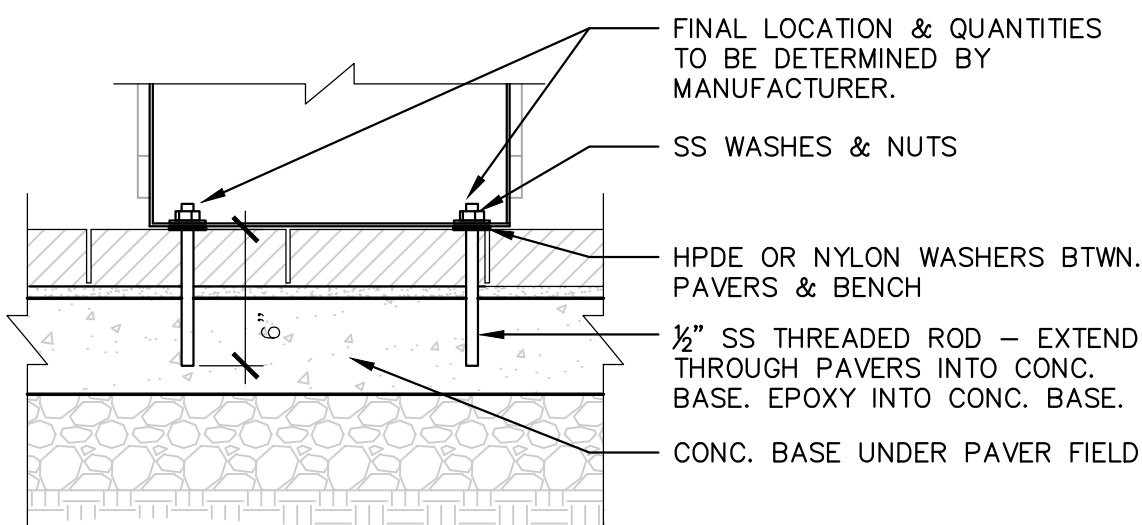

SF2622-001 1st & 2nd Street Parklet Benches

02870 (12 93 13) - 3

### LIGHTED BENCH

#### PART 1 GENERAL

##### 1.1 SECTION INCLUDES

- A. Products - Manufactured by Landscape Forms Inc.
  - SF2622-001 - PROP. BACKLESS BENCH (Or Architect Approved Equivalent)

##### 1.2 SUBMITTALS

- A. Product Data: Submit manufacturer's product data, storage and handling requirements and recommendations, installation methods and available colors, styles, Patterns and textures.
- B. Shop Drawings: Submit manufacturer's shop drawings, including plans and elevations, indicating overall dimensions.
- C. Samples: Submit manufacturer's samples of materials, finishes, and colors.
- D. Warranty: Manufacturer's standard warranty.

##### 1.3 QUALITY ASSURANCE

- A. Manufacturer's Qualifications: Manufacturer regularly engaged in manufacture of site furnishings for a minimum of 25 years.
- 1. Provide 5 similar reference projects with direct contact information.
- B. Product Support: Products are supported with complete engineering drawings. Submit final engineered shop drawings for Architect review prior to manufacture.
- C. Insurance: Liability insurance coverage of two million dollars
- D. Facility Operator: Welders and machine operators are certified for all AWS & ASTM standards that apply.

##### 1.4 DELIVERY, STORAGE, AND HANDLING

- A. Delivery: Deliver materials to site in manufacturer's original, unopened containers and packaging, with labels clearly identifying product name and manufacturer.
- B. Storage: Store materials in clean, dry area in accordance with manufacturer's instructions. Keep materials in manufacturer's original, unopened containers and packaging until installation.
- C. Handling: Protect materials and finish during handling and installation to prevent damage.

##### 1.5 WARRANTY

- A. Warranty Information:
  - Products will be free from defects in material and/or workmanship for a period of three years from the date of invoice.
  - The warranty does not apply to damage resulting from accident, alteration, misuse, tampering, negligence, or abuse.
  - Product, at the option of manufacturer, repair, replace, or refund the purchase price of any items found defective upon inspection by an authorized service representative.

#### PART 2 PRODUCTS

##### 2.1 MANUFACTURER

- A. Landscape Forms, Inc., 7800 East Michigan Ave, Kalamazoo, Michigan 49048. Toll Free (800) 521-2546. Phone (269) 381-0396. Fax (269) 381-3455. Website www.landscapeforms.com. E-mail specify@landscapeforms.com.
- B. Architect Approved Equivalent Manufacturer. Contractor shall submit alternative Manufacturer prior to bidding of project. Alternative manufacturers or products will not be approved after bid letting.

##### 2.2 PRODUCTS

###### A. 1st & 2nd Street Parklet Benches

- B. Style:
  - SF2622-001 - PROP. BACKLESS BENCH
    - Overall Height: 18"- Seat & 22"- Table
    - Overall Width: 20"
    - Length: 9'
- C. Mounting:
  - SF2622-001
    - Surface mounted with stainless steel hardware

##### 2.3 MATERIAL

- A. SF2622-001 - PROP. BACKLESS BENCH
  - Frame: A36 Carbon Steel
  - Hardware: 18-8 Stainless Steel
  - White acrylic diffuser panel
  - Static LED lighting and transformer

- B. All seat boards are IPE or Jarrah- exterior grade hardwood:
  - Seat board sizes per plans

##### 2.4 RECYCLED CONTENT

- A. Product:
  - Recycled Material Content: Minimum 65 percent.
  - Post-Consumer Material Content: Minimum 50 percent.
  - Pre-Consumer Material Content: Minimum 15 percent.
  - Recyclable: 100 percent.

##### 2.5 FABRICATION

- A. Shop fabricated & assembled benches.

##### 2.6 FINISHES

- A. Finish on Metal: Landscape Forms, Inc. "Pangard II" or Architect Approved Equivalent
  - Primer: Rust inhibitor.
  - Topcoat: Thermosetting TGIC polyester powder coat. UV, chip, and flake resistant.
  - Test Results: "Pangard II".
    - Gloss Consistency, Gardner 60 Degrees, ASTM D 523: Plus or minus 5 percent from standard.
    - UV Resistance, Color and Gloss, ASTM G 155, Cycle 7: Delta E less than 2 at 2.0 mils and less than 20 percent loss.
    - Cross-Hatch Adhesion, ASTM D 3359, Method B: 100 percent pass.
    - Flexibility Test, Mandrel, ASTM D 522: 3 mm at 2 mils.
    - Erichsen Cupping, ISO 1520: 8 mm.
    - Impression Hardness, Buchholz, ISO 2815: 95.
    - Impact Test, ASTM D 2794: 60 inch-pounds at 2.5 mils.
    - Pencil Hardness, ASTM D 3363: 2H minimum.
    - Corrosion Resistance, 1,500-Hour Test, ASTM B 117: Max undercutting 1 mm.
    - Humidity Resistance, 1,500-Hour Test, ASTM D 2247: Max blisters 1 mm.
- Color: RAL Textured Nutmeg.

##### B. Wood Finish:

- 1. Ipe or Jarrah wood seats to be natural. No oil, stain, varnish or paint

#### PART 3 EXECUTION

##### 3.1 EXAMINATION

- A. Examine areas to receive product.
- B. Notify Architect of conditions that would adversely affect installation or subsequent use.
- C. Do not begin installation until unacceptable conditions are corrected.

##### 3.2 INSTALLATION

- A. Install in accordance with manufacturer's instructions at locations indicated on the Drawings.
- B. Install level.
- C. Anchor securely in place.

##### 3.3 ADJUSTING

- A. Finish Damage: Repair minor damages to finish in accordance with manufacturer's instructions and as approved by Architect.
- B. Component Damage: Remove and replace damaged components that cannot be successfully repaired as determined by Architect.

##### 3.4 CLEANING

- A. Clean products promptly after installation in accordance with manufacturer's instructions.
- B. Do not use harsh cleaning materials or methods that could damage finish.

##### 3.5 PROTECTION

- A. Protect installed product to ensure that, except for normal weathering, racks will be without damage or deterioration at time of Substantial Completion.

Tran Systems

245 NORTH WACO  
SUITE 222  
WICHITA, KANSAS 67202  
PHONE: 316-303-3000  
FAX: 316-303-0166

CONSULTANTS:

LK Architecture, Inc. ©  
345 NORTH RIVERVIEW ST.  
SUITE 200  
WICHITA, KANSAS 67203  
PHONE: 316-268-0230

2ND STREET IMPROVEMENTS  
SANTA FE TO WASHINGTON IN OLD TOWN

WICHITA, KANSAS



REVISIONS:	MARK	DATE	DESCRIPTION

PROJ NO: 472-85284  
SCALE: N/A  
DATE: 07/13/2018  
DESIGNED BY: WAWELLS  
DRAWN BY: WAWELLS  
CHECKED BY: JABEST

SHEET TITLE:  
CUSTOM BENCH DETAILS & NOTES

SHEET NO.  
15  
SHEET 15 OF 103