

**LEGEND**

- Contraction Joint
- Longitudinal Joint
- Expansion Joint
- Proposed Water Flow

Note:  
All concrete pavement on 2nd Street shall be "Concrete Pavement, 9' (NRDJ)" unless otherwise noted in the plans or by the Engineer, for Concrete Pavement 9' (NRDJ) details, See Sheets 48 & 49

All concrete pavement on valley gutters shall be "Concrete Pavement (VG) 8' (Reinf.)" See Sheet 50

Pavement joints shall be continued through curb & gutter and match joint patterns where possible.

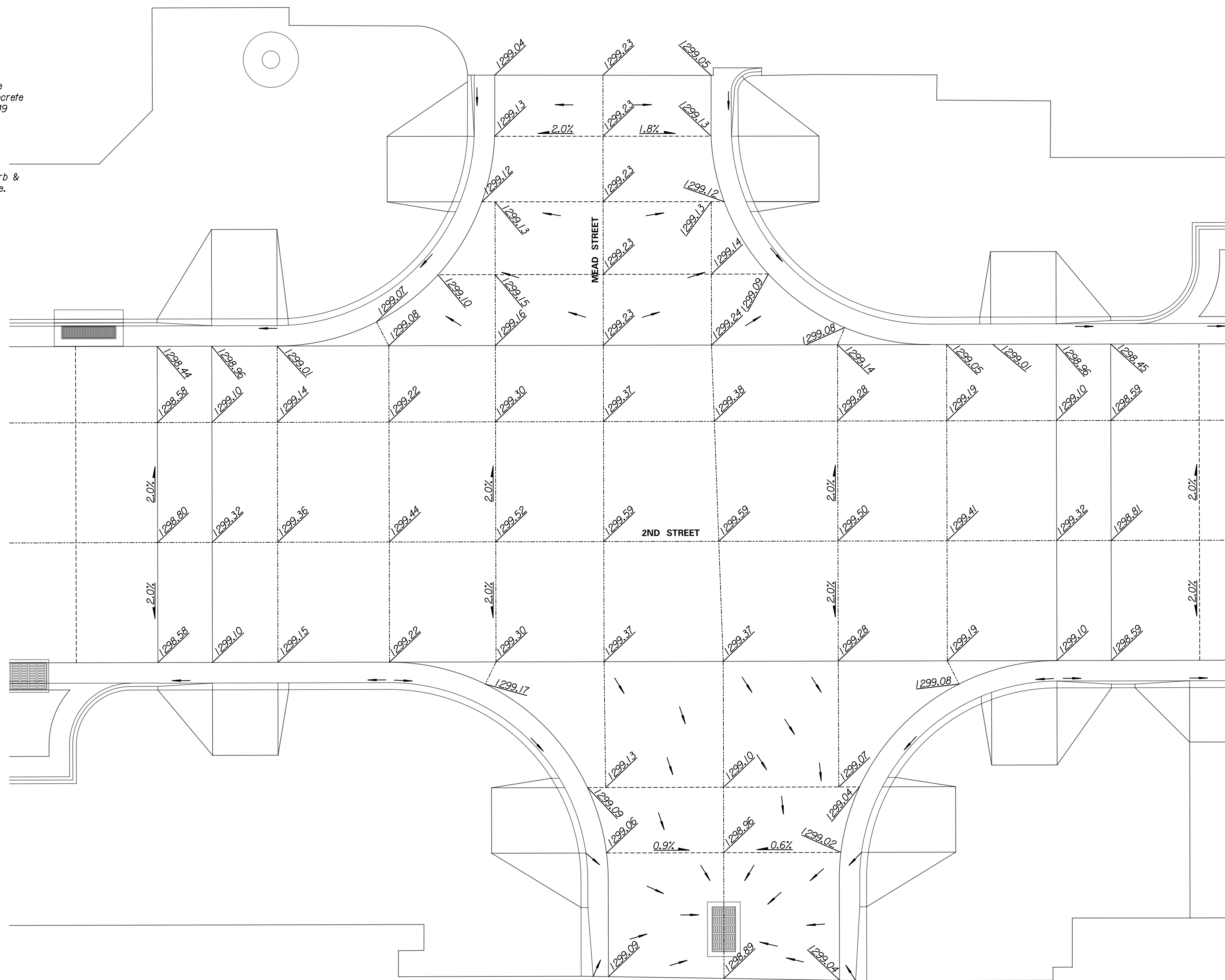
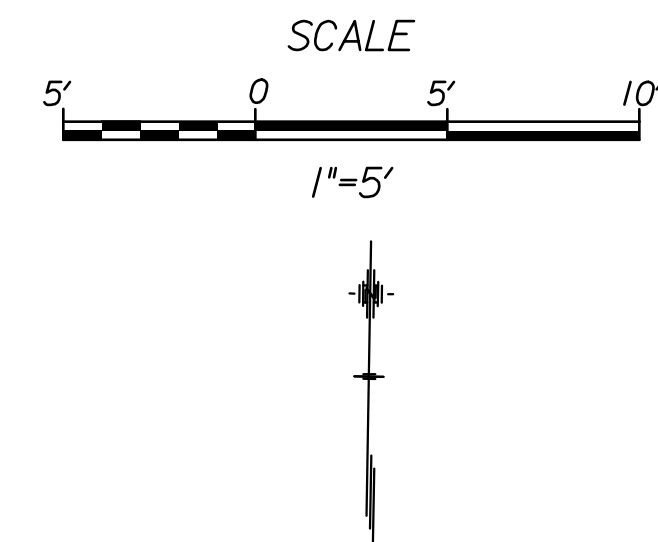

**Tran Systems**  
 245 NORTH WACO  
 SUITE 222  
 WICHITA, KANSAS 67202  
 PHONE: 316-303-3000  
 FAX: 316-303-0166

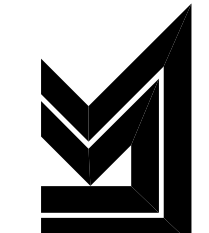
CONSULTANTS:  
  
 LK ARCHITECTURE, INC.  
 345 RIVERVIEW  
 SUITE 200  
 WICHITA, KANSAS 67208  
 PHONE: 316-268-0230

2ND STREET IMPROVEMENTS  
 SANTA FE TO WASHINGTON IN OLD TOWN  
 WICHITA, KANSAS  

REVISIONS:	MARK	DATE	DESCRIPTION

PROJ NO: 472-85284  
 SCALE: 1"=5'  
 DATE: 7/11/2018  
 DESIGNED BY: TAU  
 DRAWN BY: TAU  
 CHECKED BY: MDB

SHEET TITLE:  
**2ND STREET & MEAD INTERSECTION DETAILS**

SHEET NO.  
**35**  
 SHEET 35 OF 103