



LEGEND

-  4" Concrete Sidewalk
-  Brick Pavers
-  Proposed Water Flow

Note:
The existing brick pillars located on the south side of 2nd Street on Mead Street shall remain. The Contractor is responsible for any damage to the existing pillars. If brick pillars are damaged during construction, the Contractor shall fix them to the Engineers discretion.

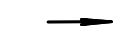
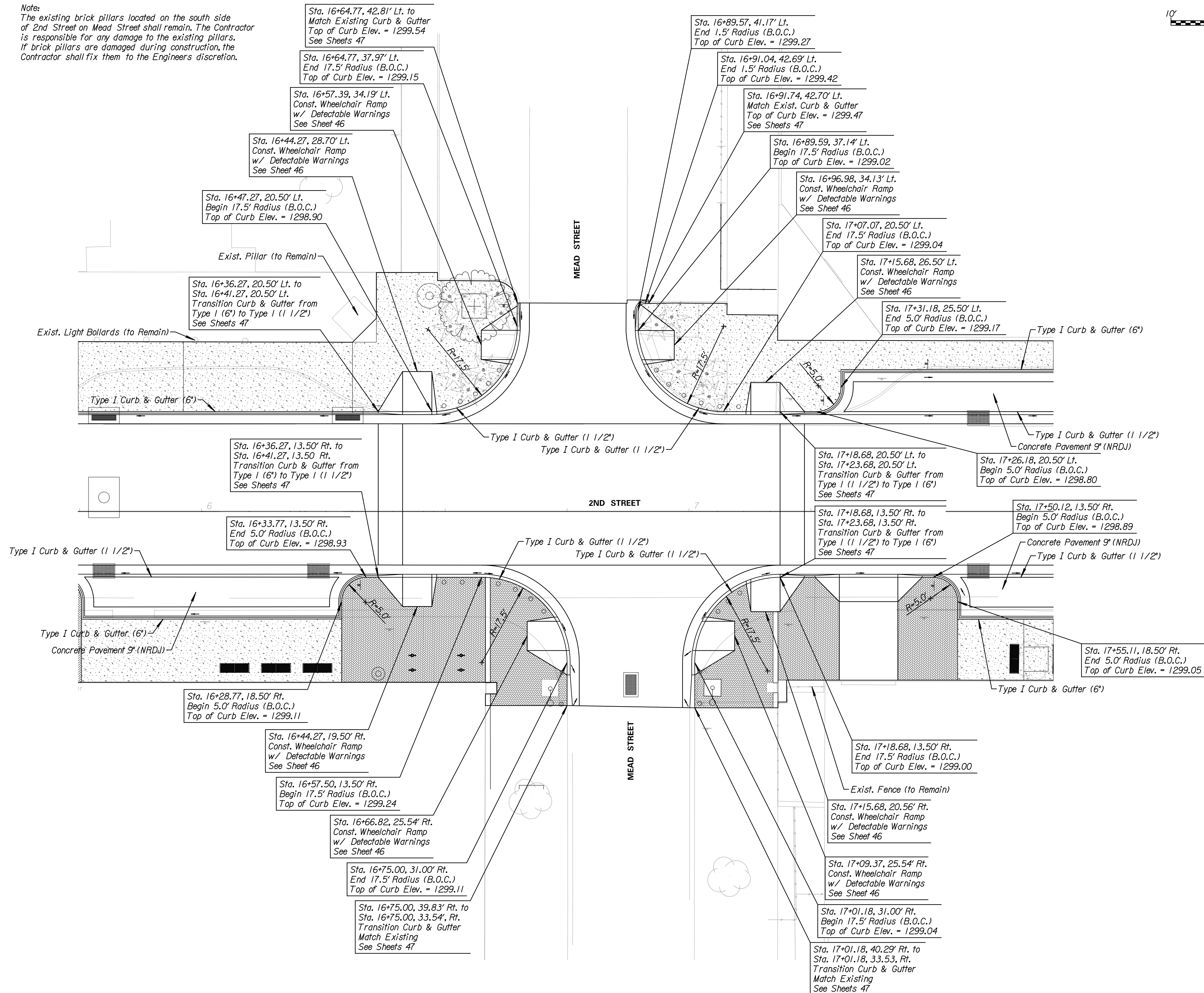
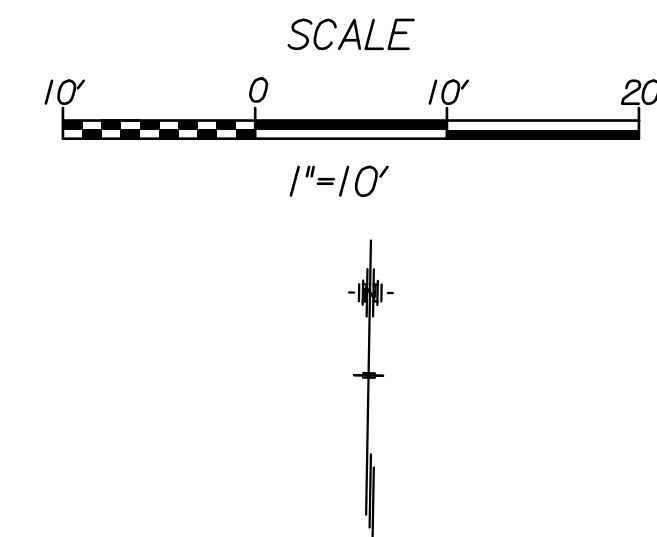

Tran Systems
245 NORTH WACO
SUITE 222
WICHITA, KANSAS 67202
PHONE: 316-303-3000
FAX: 316-303-0156

CONSULTANTS:
LK ARCHITECTURE, INC.
345 RIVERVIEW
SUITE 200
WICHITA, KANSAS 67208
PHONE: 316-268-0230

2ND STREET IMPROVEMENTS
SANTA FE TO WASHINGTON IN OLD TOWN
WICHITA, KANSAS
CITY OF WICHITA

REVISIONS:	DESCRIPTION	MARK	DATE

PROJ NO: 472-85284
SCALE: 1"=10'
DATE: 7/11/2018
DESIGNED BY: TAU
DRAWN BY: TAU
CHECKED BY: MDB

SHEET TITLE:
2ND STREET & MEAD STREET INTERSECTION LAYOUT DETAILS

SHEET NO.
39
SHEET 39 OF 103

7/11/2018 11:24:49 PM - c:\tran\systems\proj\ba\alltrans\scop\pw\taum\mead\0484377\CLAY\M02-101.dgn