



LEGEND

-  4' Concrete Sidewalk
-  Brick Pavers
-  Grass
-  Proposed Water Flow

Note:
The existing brick pillars located on the south side of 2nd Street on Mosley Street shall remain. The Contractor is responsible for any damage to the existing pillars. If brick pillars are damaged during construction, the Contractor shall fix them to the Engineers discretion.

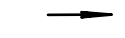
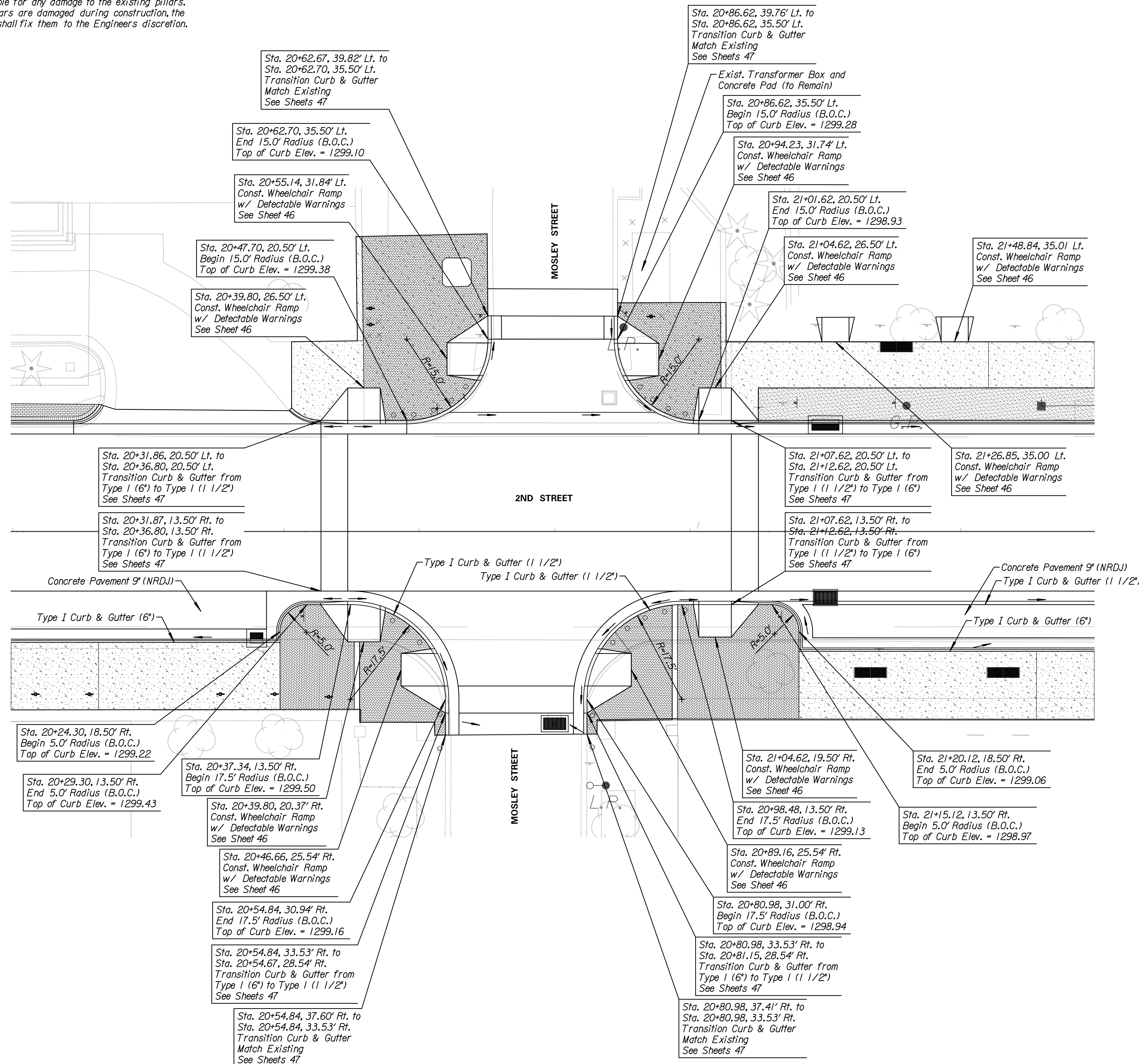
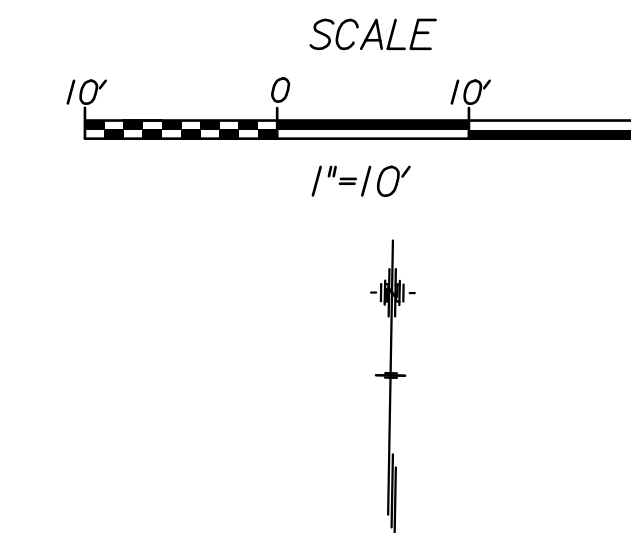

Tran Systems
 245 NORTH WACO
 SUITE 222
 WICHITA, KANSAS 67202
 PHONE: 316-303-3000
 FAX: 316-303-0166

CONSULTANTS:

 LK ARCHITECTURE, INC.
 345 RIVERVIEW
 SUITE 200
 WICHITA, KANSAS 67208
 PHONE: 316-268-0230

2ND STREET IMPROVEMENTS
 SANTA FE TO WASHINGTON IN OLD TOWN
 WICHITA, KANSAS

 CITY OF WICHITA

REVISIONS:	MARK	DATE	DESCRIPTION

PROJ NO: 472-85284
 SCALE: 1"=10'
 DATE: 7/11/2018
 DESIGNED BY: TAU
 DRAWN BY: TAU
 CHECKED BY: MDB

SHEET TITLE:
2ND STREET & MOSLEY STREET INTERSECTION LAYOUT DETAILS

SHEET NO.
43
 SHEET 43 OF 103

taummed
 7/11/2018 11:13:14 PM - c:\transtransystems\paw_ba\alltransystems\paw\taummed\0494377\CLAY\MO2-105.dgn