

PLOTTED: Wednesday, September 19, 2018 @ 10:46AM

J:\PROJECTS\2018\1401010482 - PREMIER ESTANCIA\DWG\CIVIL\CADD\RESIDENTIAL\PHASE1\482_RES_DP_06_P183A.DWG

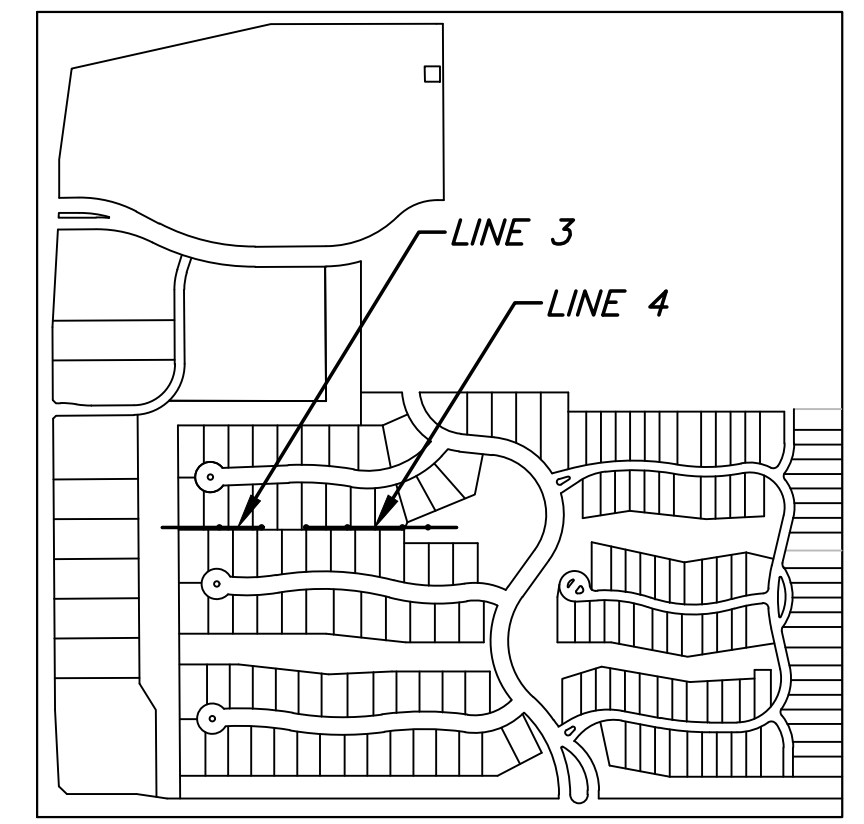

VICINITY MAP
No Scale

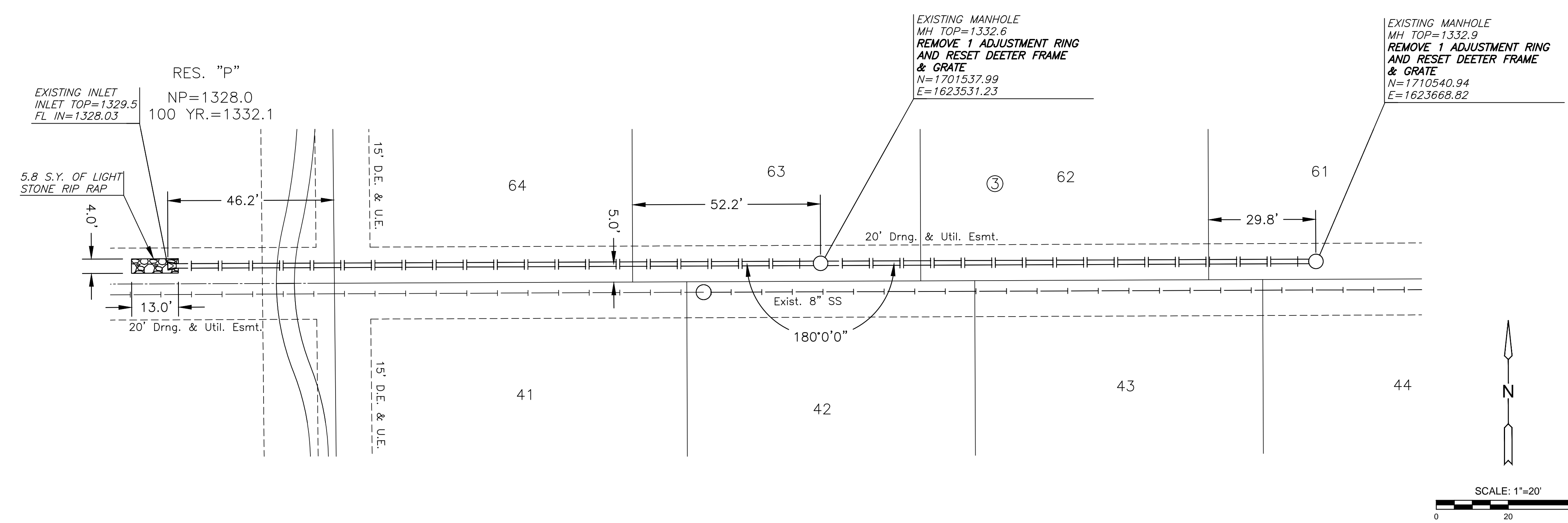
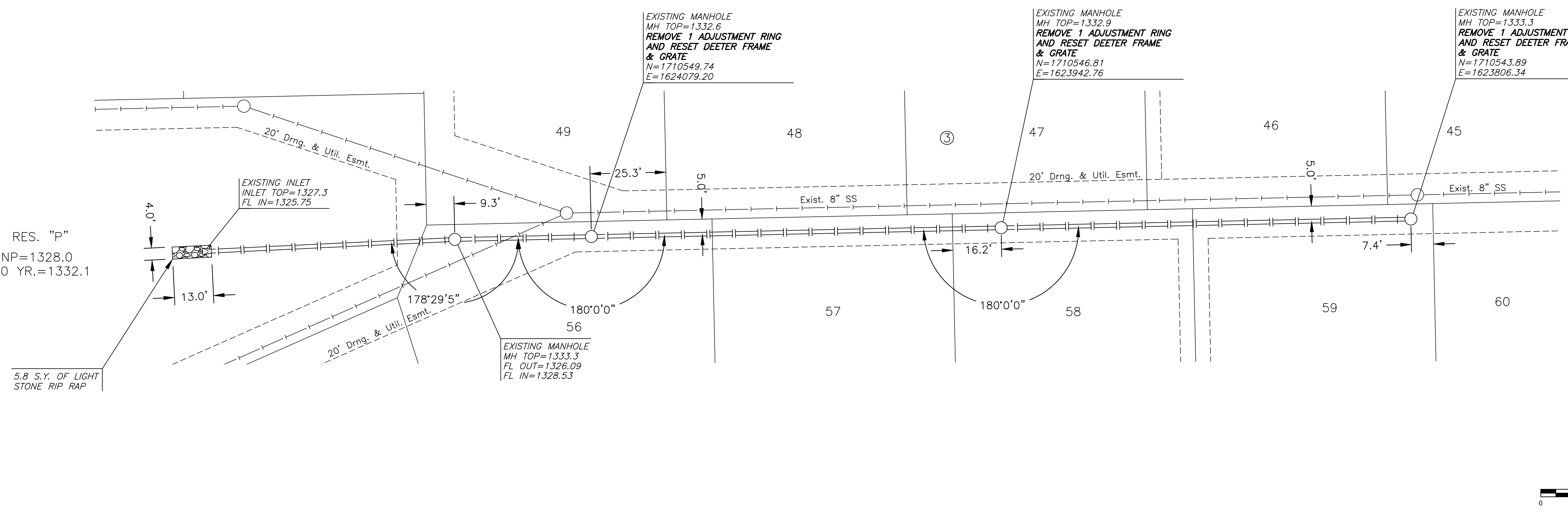

STORM WATER SEWER PLAN FOR
ESTANCIA ADDITION
PHASE 3A

©2018
MKEC Engineering
All Rights Reserved
www.mkec.com
These drawings and their contents, including, but not limited to, all concepts, designs, & ideas are the exclusive property of MKEC Engineering (MKEC), and may not be used or reproduced in any way without the express consent of MKEC.

MANHOLE ADJUSTMENTS

PROJECT NO.	468-85074	
DATE	SEPT. 2018	
SCALE	1" = 20'	
DESIGNED	DRAWN	CHECKED
DFL	JWC	GJA

NO.	REVISION	DATE