

SERVICE BOX CONSTRUCTION/INSTALLATION DETAILS

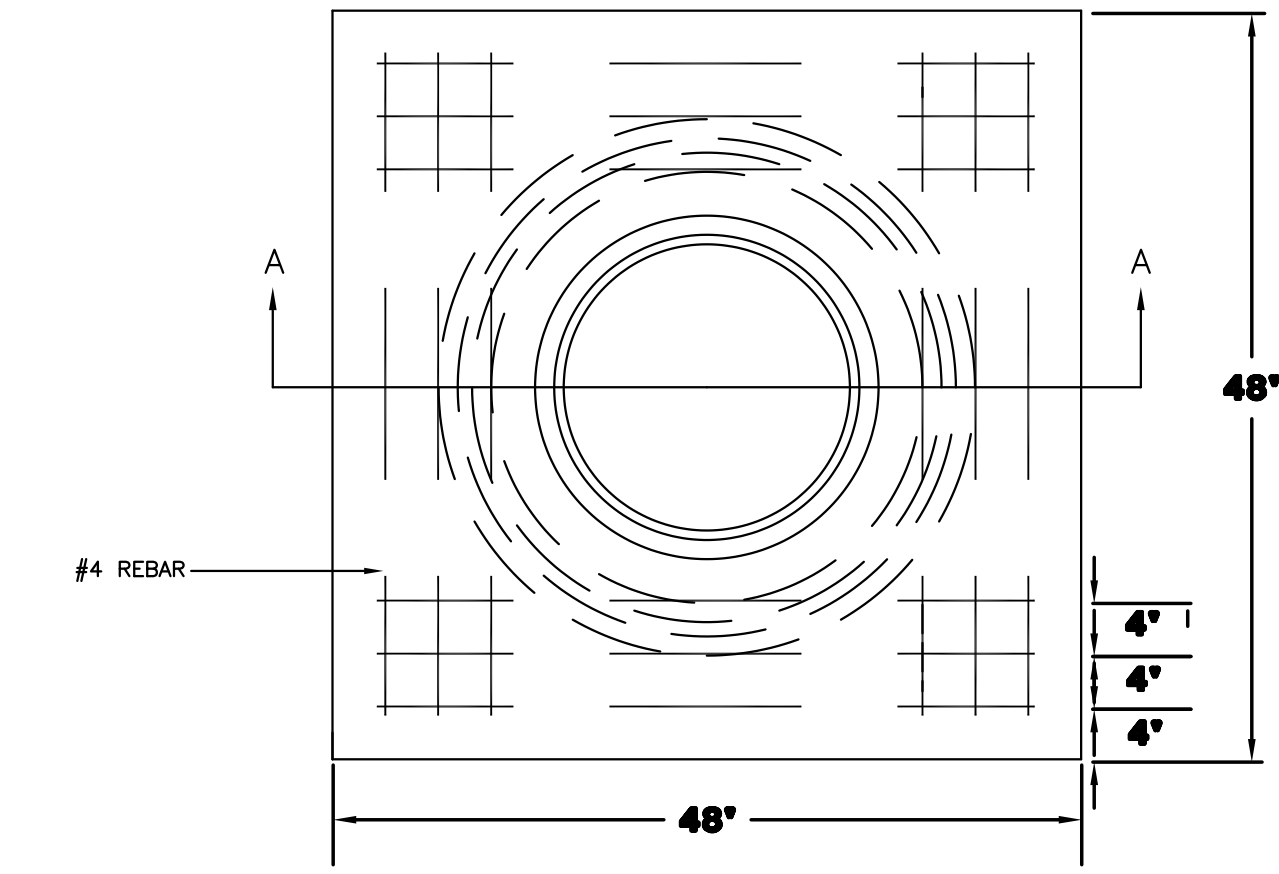

PRE-CAST CONCRETE SERVICE BOX
(36" I.D. X 54" RCP)
with 6" CAP

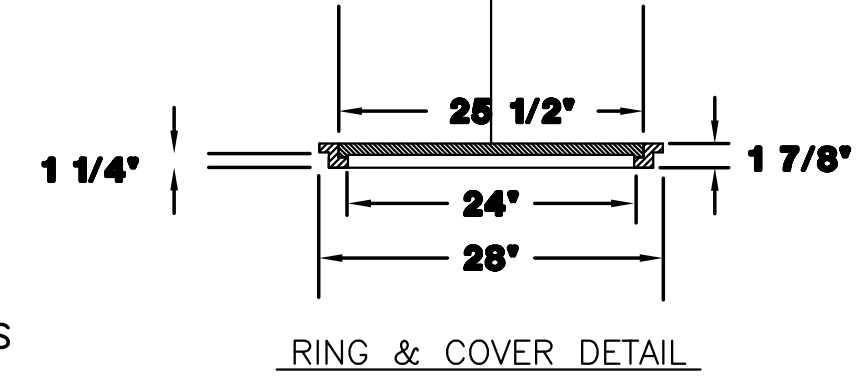
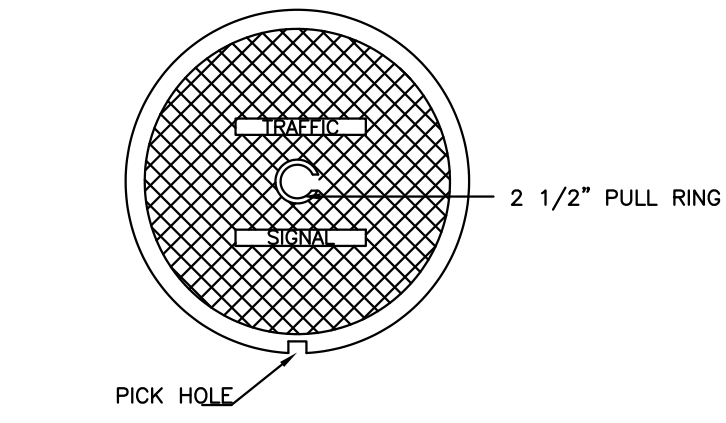
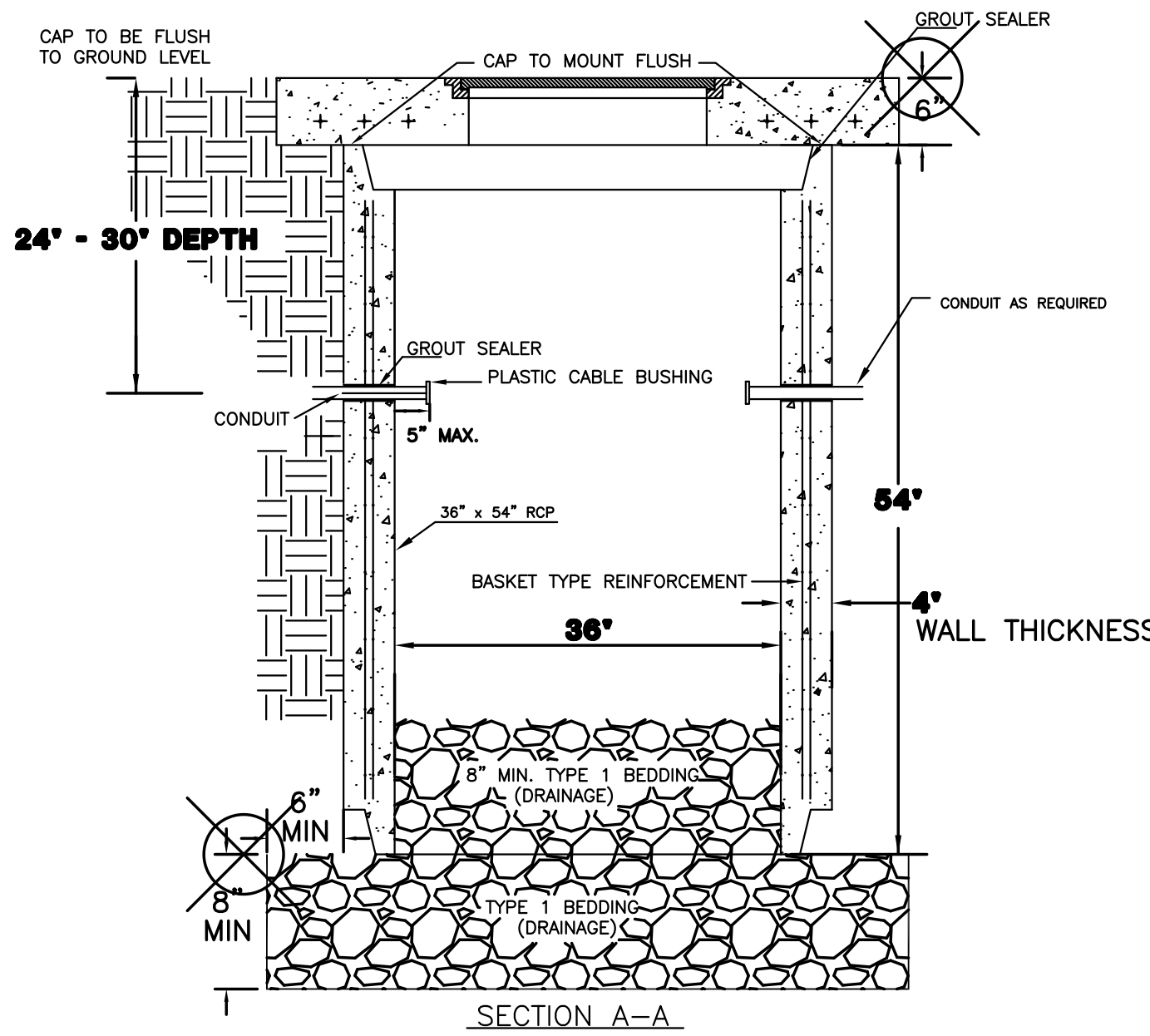

CONDUIT/DETECTOR WIRE INSTALLATION DETAILS

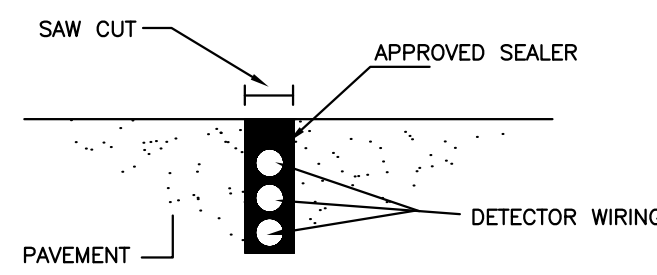

STD. CURB & GUTTER

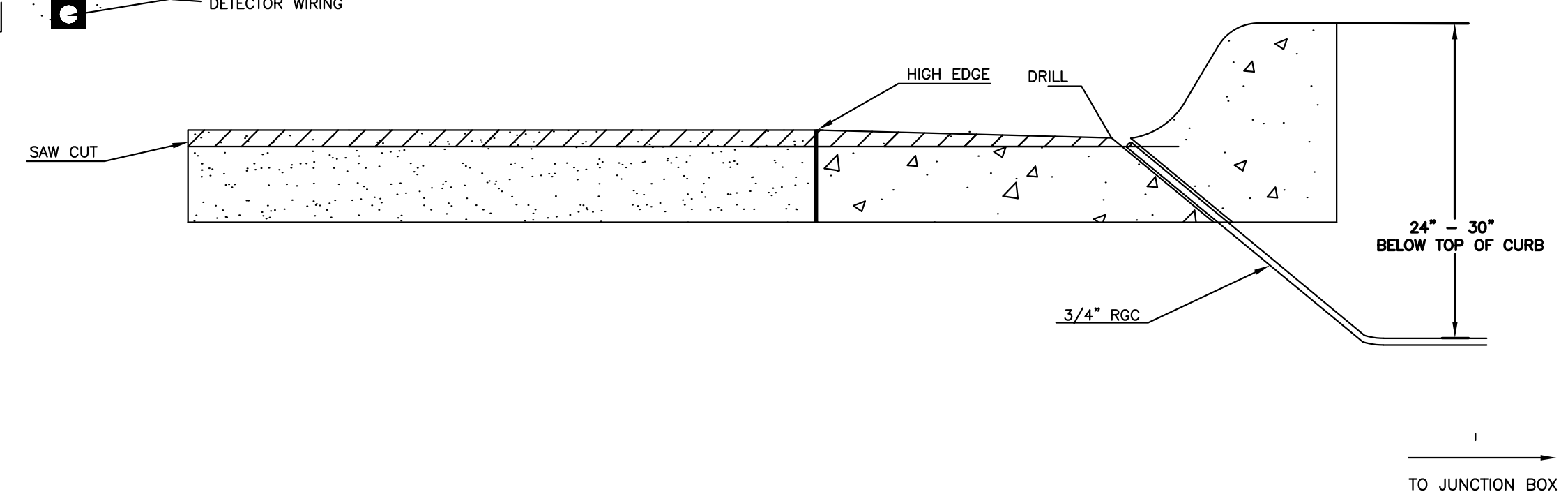

2070 CONTROLLER PAD DETAILS

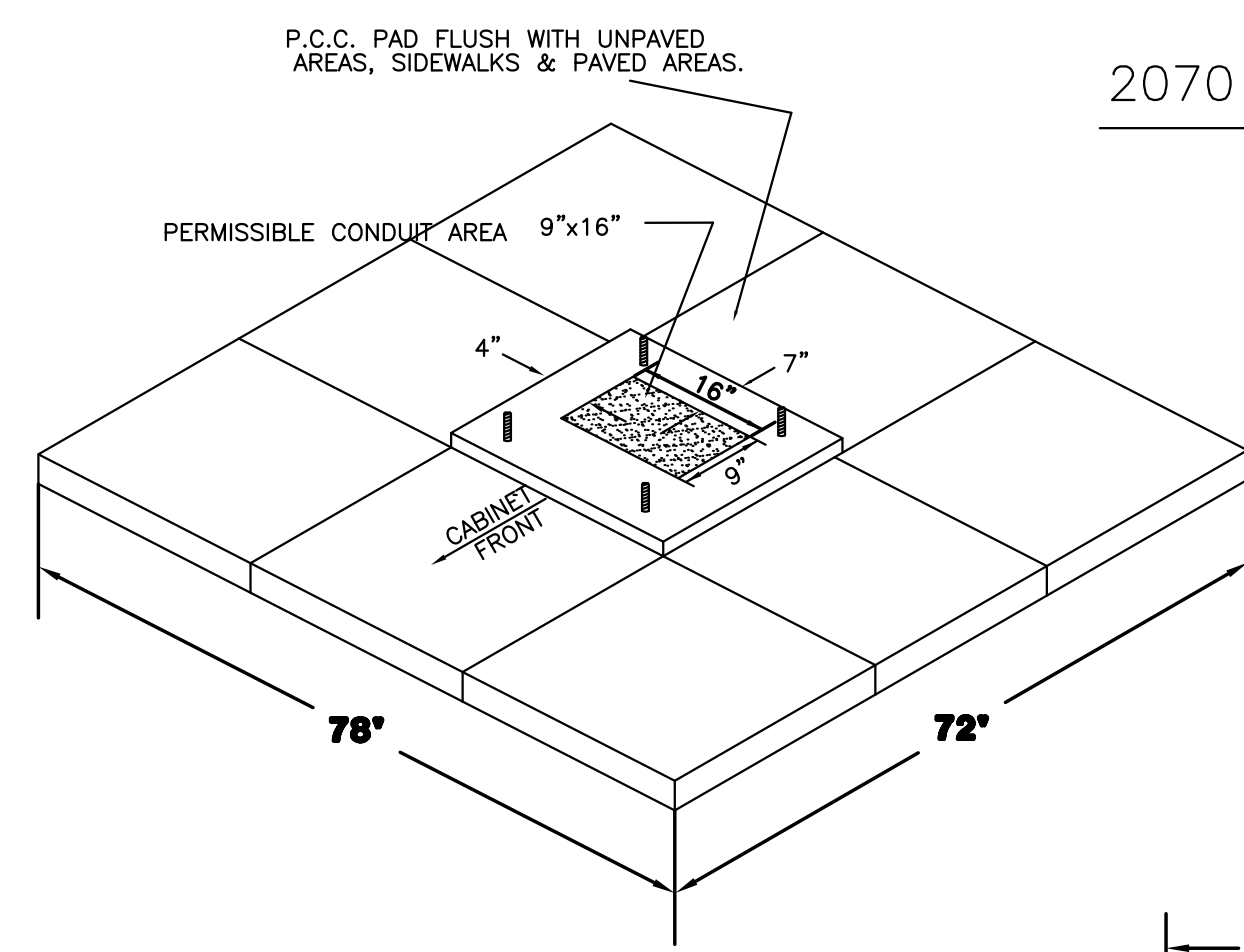

REBAR SHALL BE ASTM A615M GRADE 300 MEETING THE REQUIREMENTS OF SUBSECTION SPECIFICATIONS.

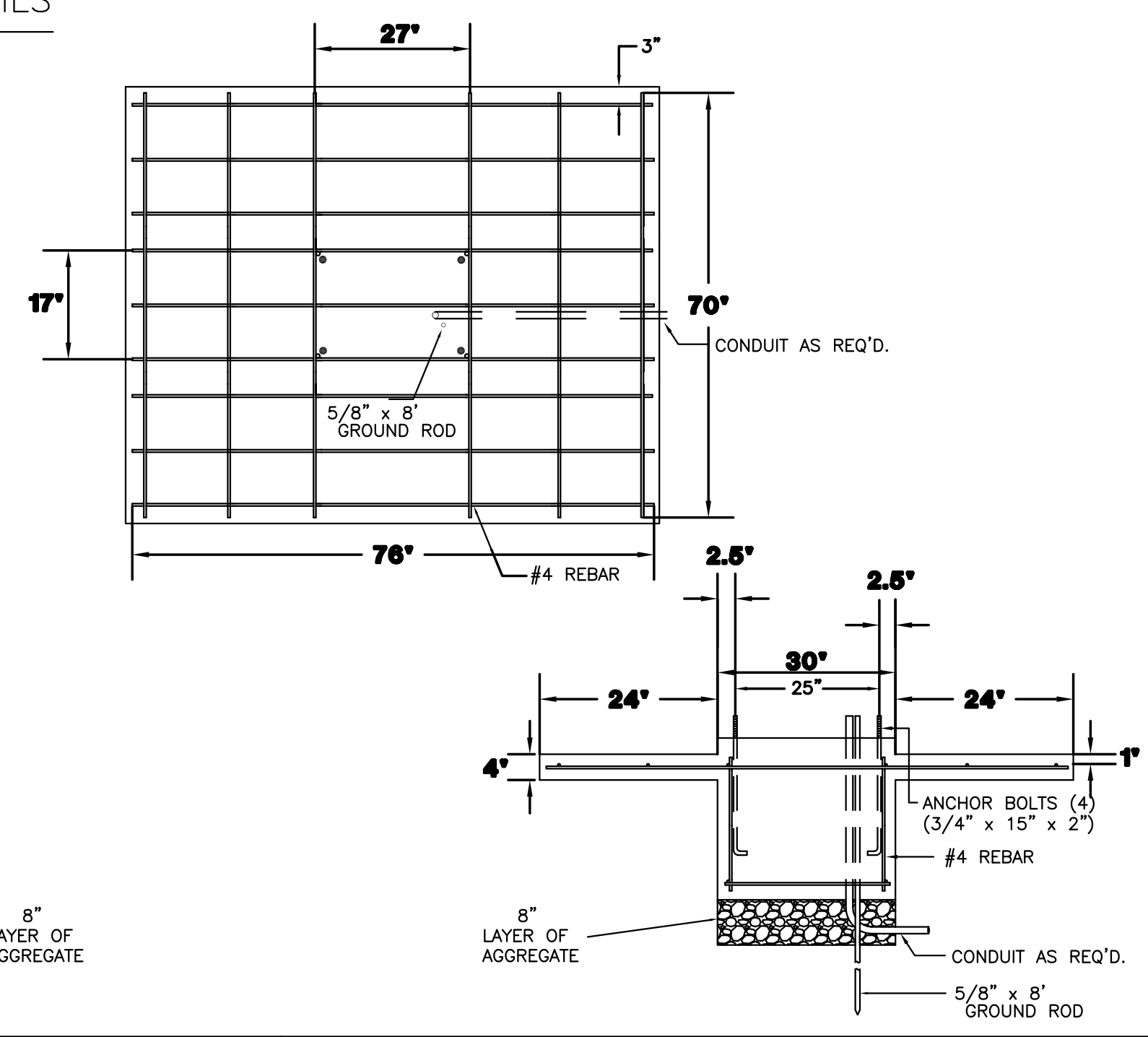
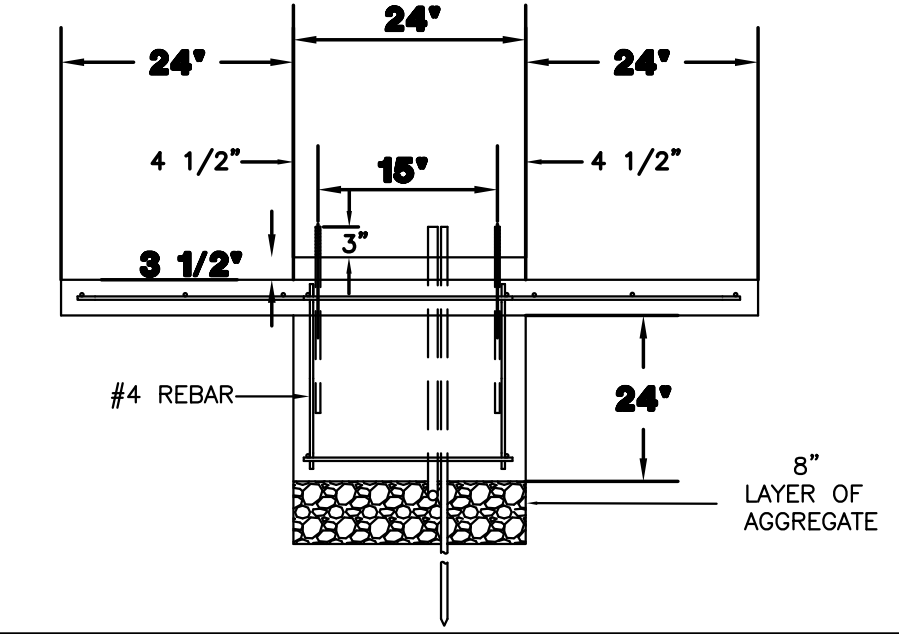

JUNCTION BOX DETAILS

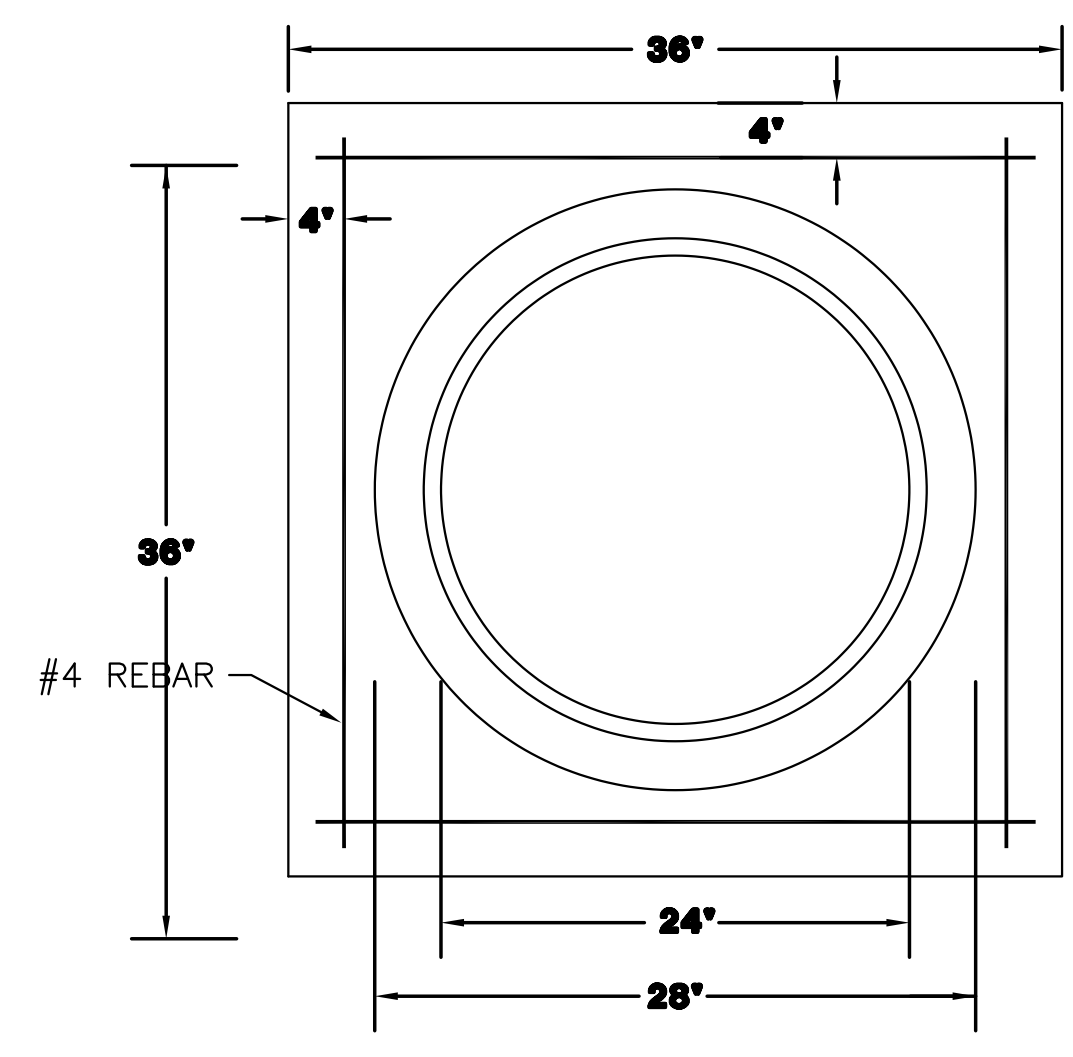
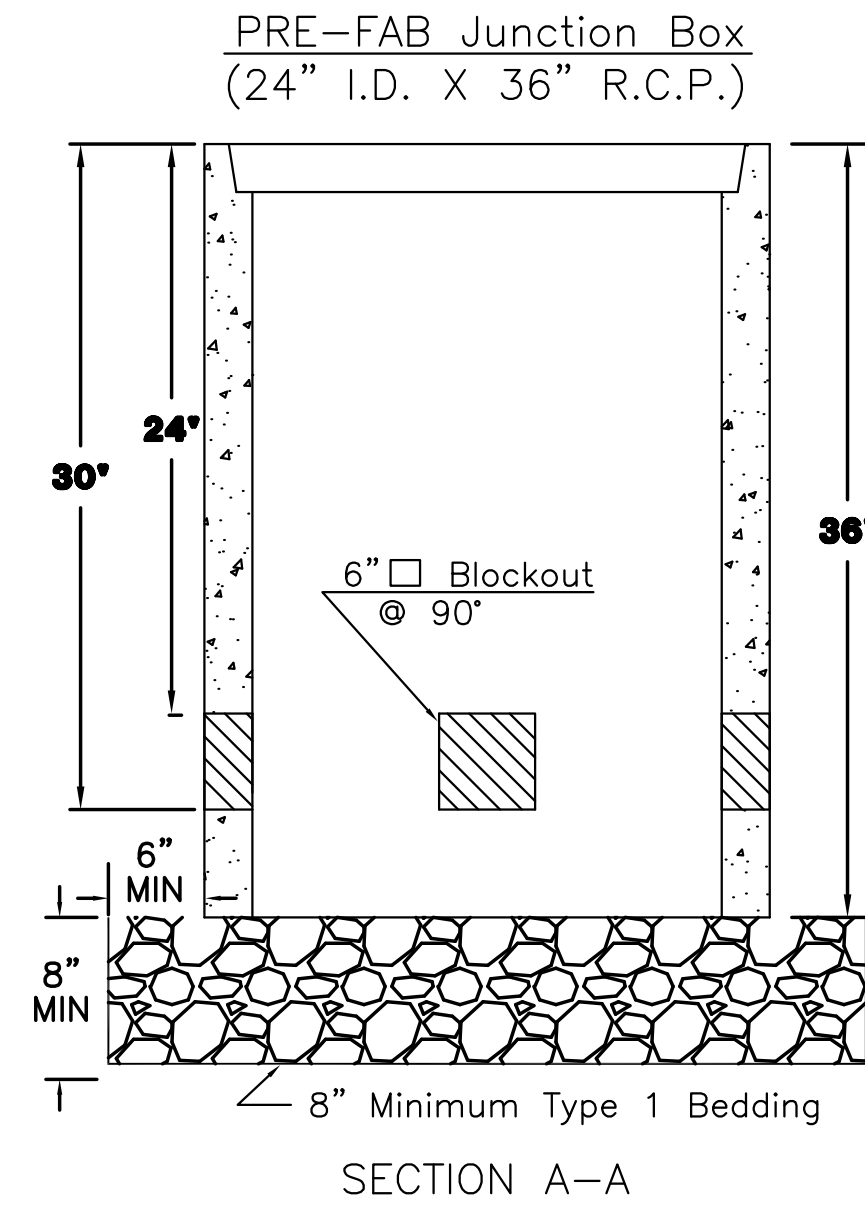

JUNCTION BOX CAP
36" x 36" x 6"
TOP OF CAP TO BE FLUSH WITH GROUND LEVEL.

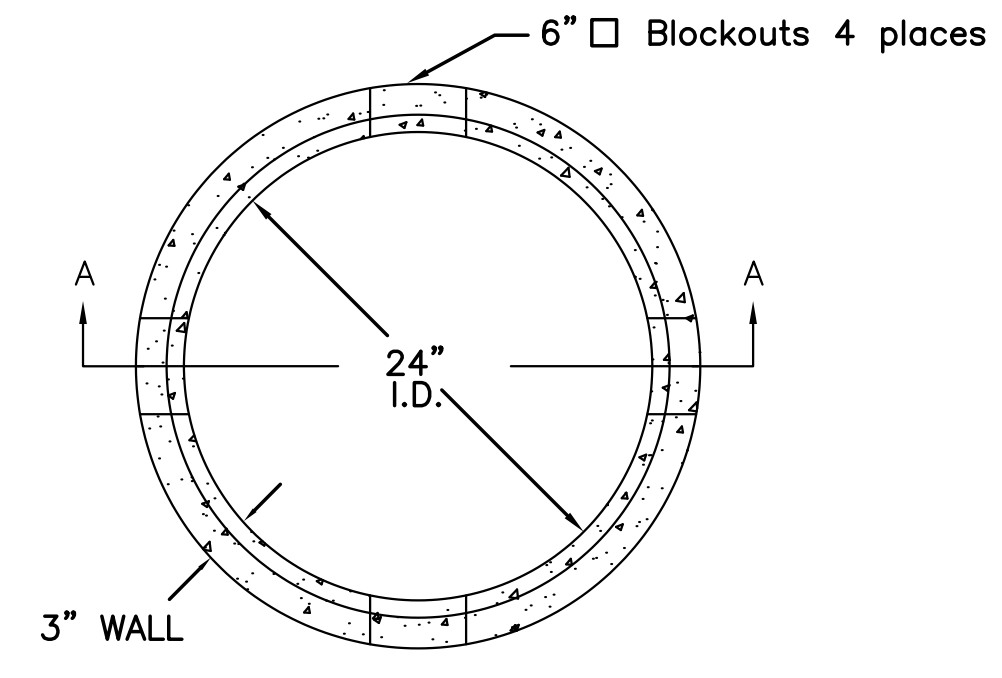

** SEE SERVICE BOX INSTALLATION FOR RING & COVER DETAILS.

NOTES:

- SERVICE & JUNCTION BOX:
- CONDUIT CONNECTION TO BE FLUSH TO WITHIN 5" OF INSIDE FACE OF SIDE WALL, CONDUIT TO DRAIN INTO SERVICE BOX.
 - CONDUIT CONNECTIONS TO SERVICE BOX SHALL BE TERMINATED WITH PLASTIC CABLE BUSHING.
 - CONDUIT SHALL BE SEALED WITH APPROVED SEALER AT INSIDE WALL FACE.
 - ALL SERVICE & JUNCTION BOXES TO HAVE 8" OF CRUSHED ROCK.
 - No 90 degree elbows unless approved by Traffic Maintenance
- TRENCHING:
- DEPTH TO BE 30" MINIMUM WITH ROCK & STUBBLE FREE BACKFILL TO SERVE AS BEDDING MATERIAL. MAINTAIN MINIMUM CONDUIT DEPTH IN TRENCH.
 - BACKFILL TO BE COMPACTED IN 6" LOOSE LIFTS BY HAND OR MECHANICAL TAMPING TO A 95% STANDARD DENSITY.
- CONDUIT:
- SLOPE CONDUIT TO DRAIN AS DIRECTED BY THE ENGINEER.
 - 3" RIGID STEEL CONDUIT BTWN. SERVICE BOXES.
 - 2" " " " BTWN. SERVICE BOX AND POLE.
 - 1 1/4" " " " BTWN. SERVICE & JUNCTION BOXES.
 - 3/4" " " " BTWN. JUNCTION BOXES.
 - 3/4" " " " BTWN. JUNCTION BOX & DETECTOR LOOP SAW CUT
- No 90 degree elbows unless approved by Traffic Maintenance

CITY OF WICHITA
PUBLIC WORKS & UTILITIES
ENGINEERING DIVISION

SERVICE/JUNCTION BOX, CONTROLLER PAD CONSTRUCTION/INSTALLATION		
TRAFFIC ENGINEER BRIAN COON, P.E.		
PROJECT NUMBER 472-85451	OCA NUMBER 766424	DATE
CITY ENGINEER'S OFFICE CITY HALL - SEVENTH FLOOR 455 NORTH MAIN STREET WICHITA, KANSAS 67202-1620 (316) 268-4501		SHEET 25 OF 37

REVISED AUGUST 2014