

SERVICE TYPES

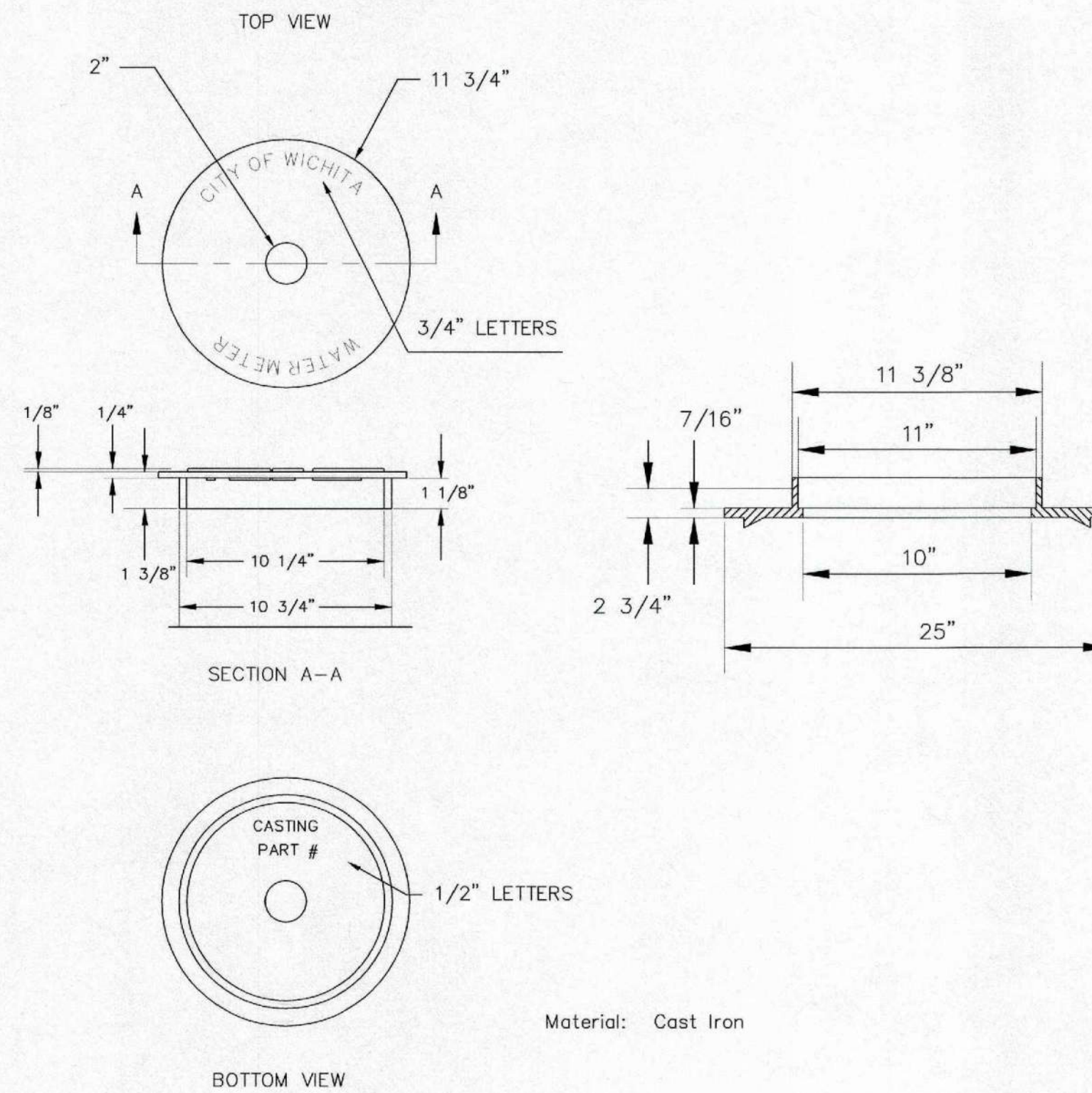

NOT TRAFFIC RATED
RING & LID FOR 1" METER BOX

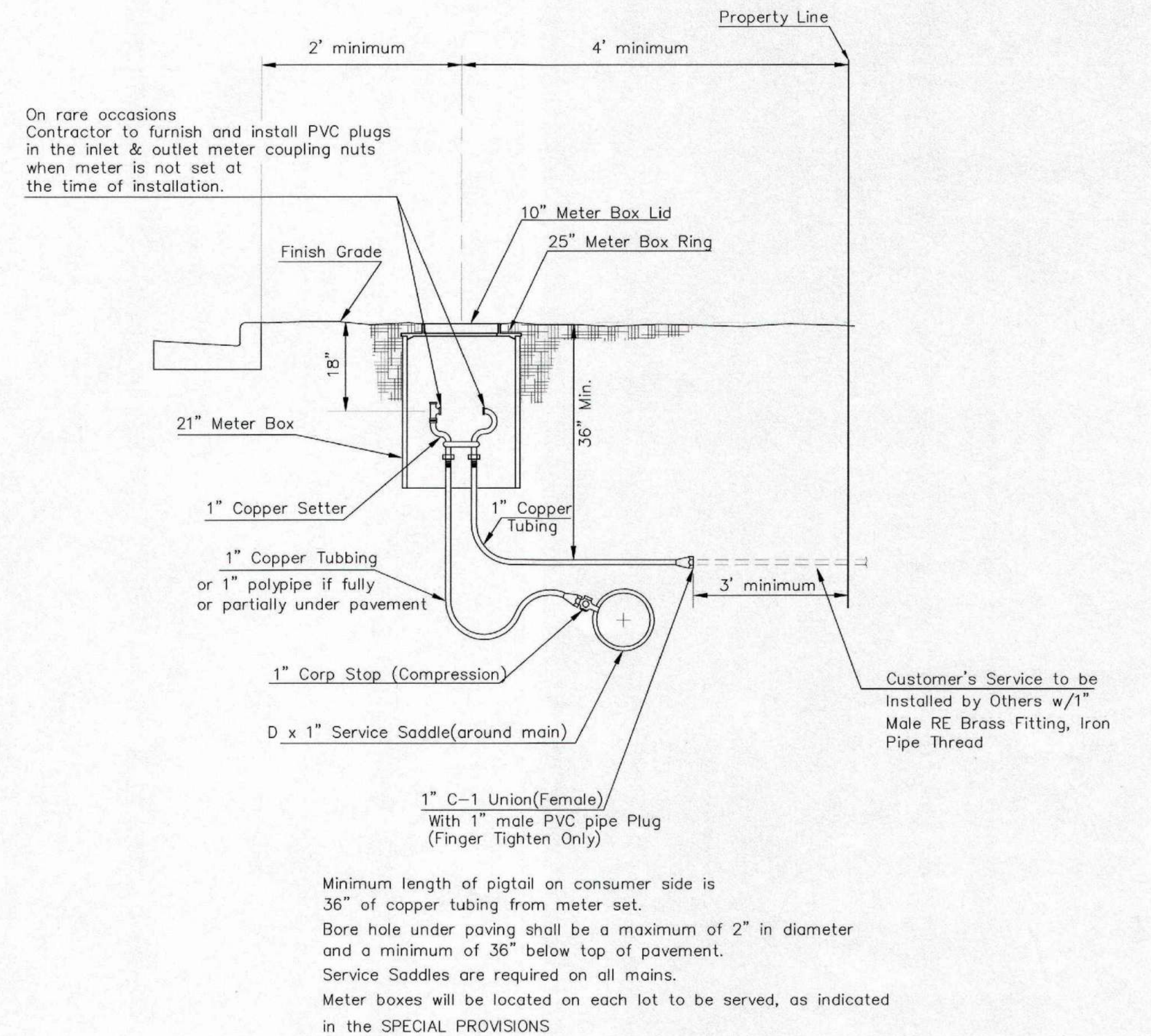

TYPICAL 1" METER SETTING

NOTE:

THE 1 1/2" AIR RELEASE ASSEMBLY WILL TYPICALLY BE USED ON WATER MAINS 24" AND SMALLER, AS SPECIFICALLY DESIGNATED IN THE PLANS. COMBINATION AIR RELEASE ASSEMBLIES WILL BE SPECIFICALLY DESIGNED FOR PROJECTS WITH LARGER MAINS, AND WILL BE INCLUDED IN THE PLANS.

- 1 - Ø Mueller Thread Corporation Stop
- Ø Type "K" Copper Tubing
- 1 - Ø Copper to Iron Union (Male)
- 1 - Ø Brass Curb Stop (Iron to Iron)
- 2 - Øx4" Brass Nipple
- Air Release
- 2 - Ø Brass Elbows (90°)
- 1 - 1"x6" Brass Nipple
- 1 - 30" Monitor Cover
- 1 - 20" Meter Lid

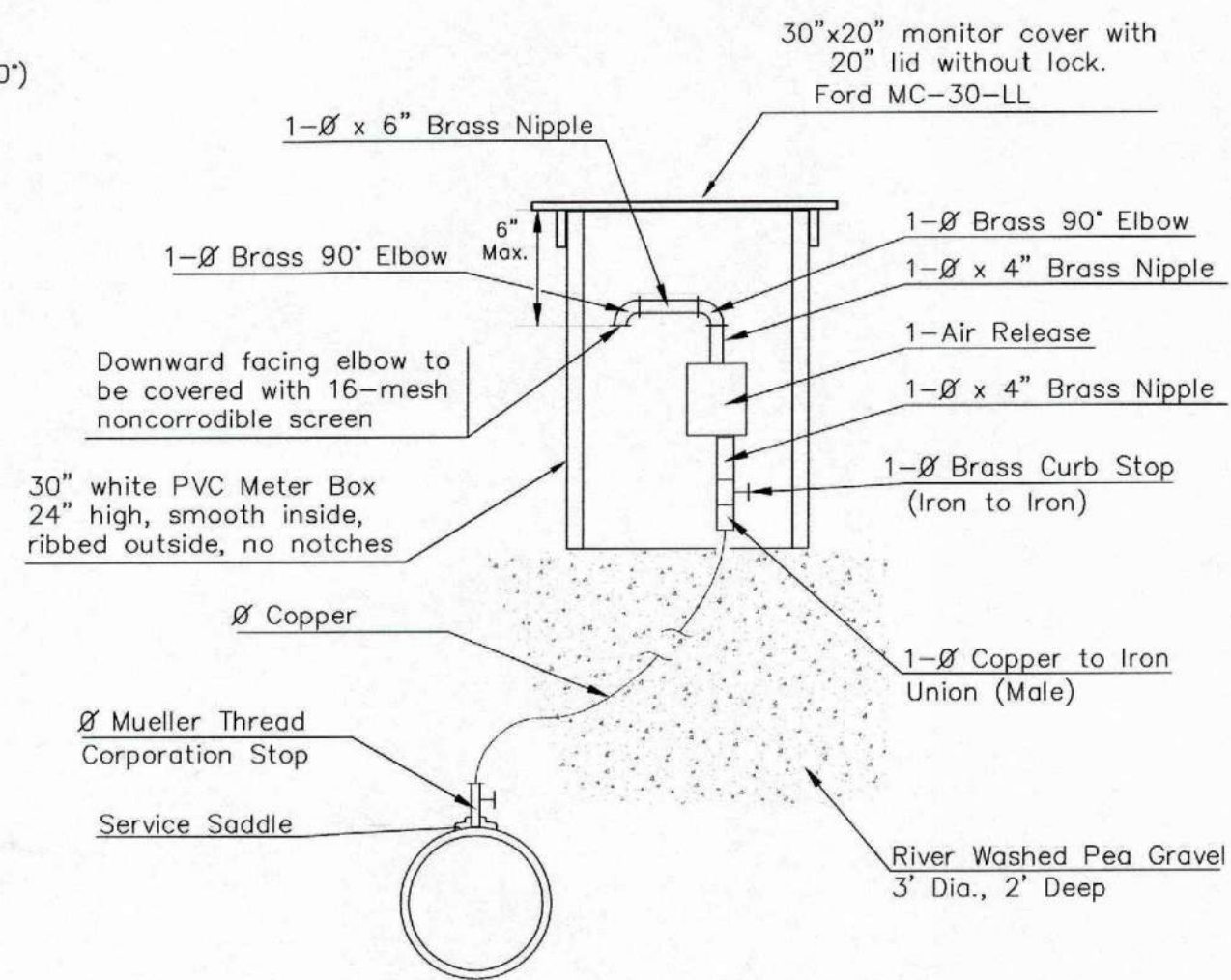

MATERIALS FOR 1" or 2" AIR RELEASE ASSEMBLY
Ø = 1" or 2"

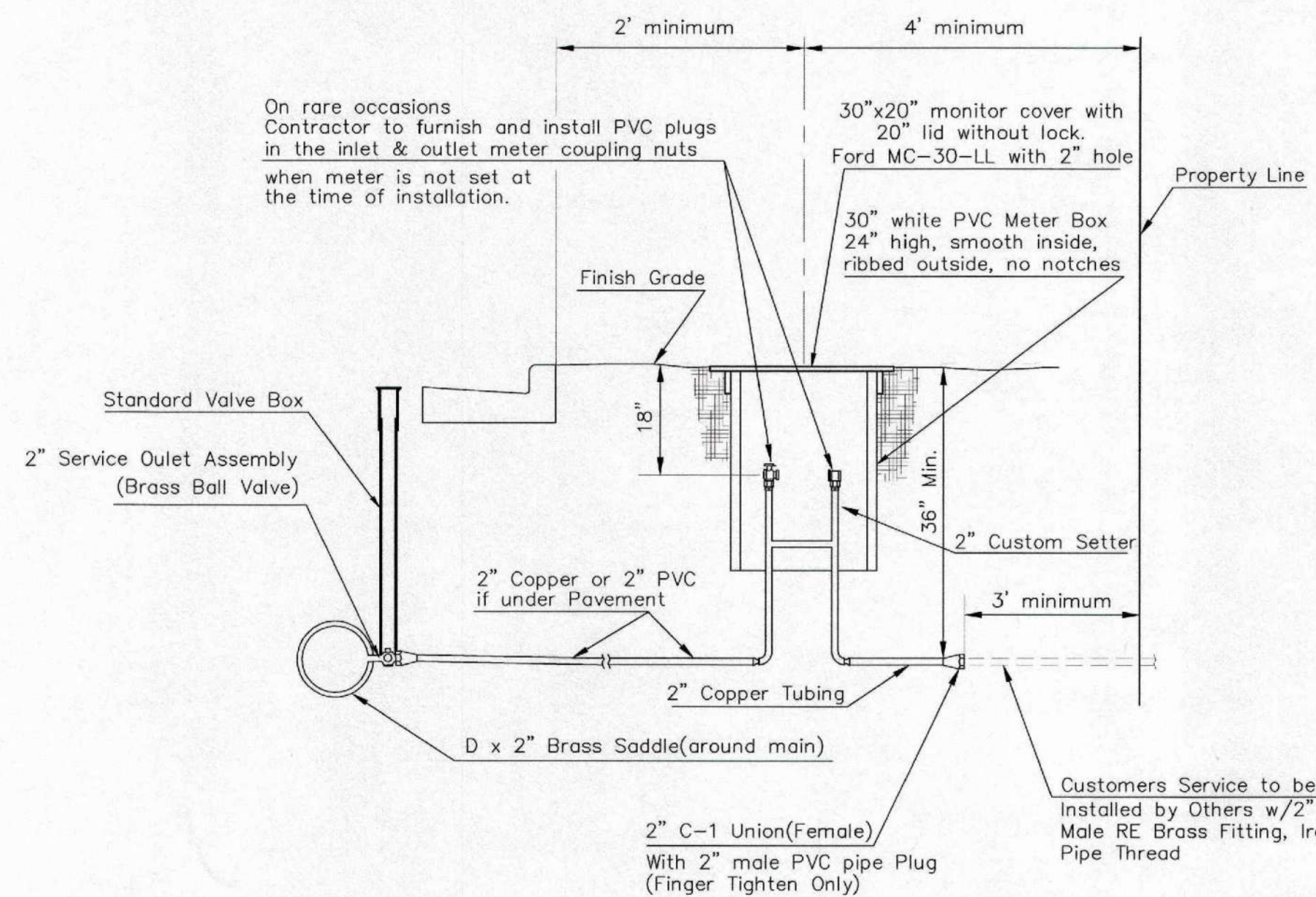

TYPICAL 2" METER SETTING

Note: ONE VALVE STEM EXTENSION FOR EACH VALVE BURIED GREATER THAN 5'.

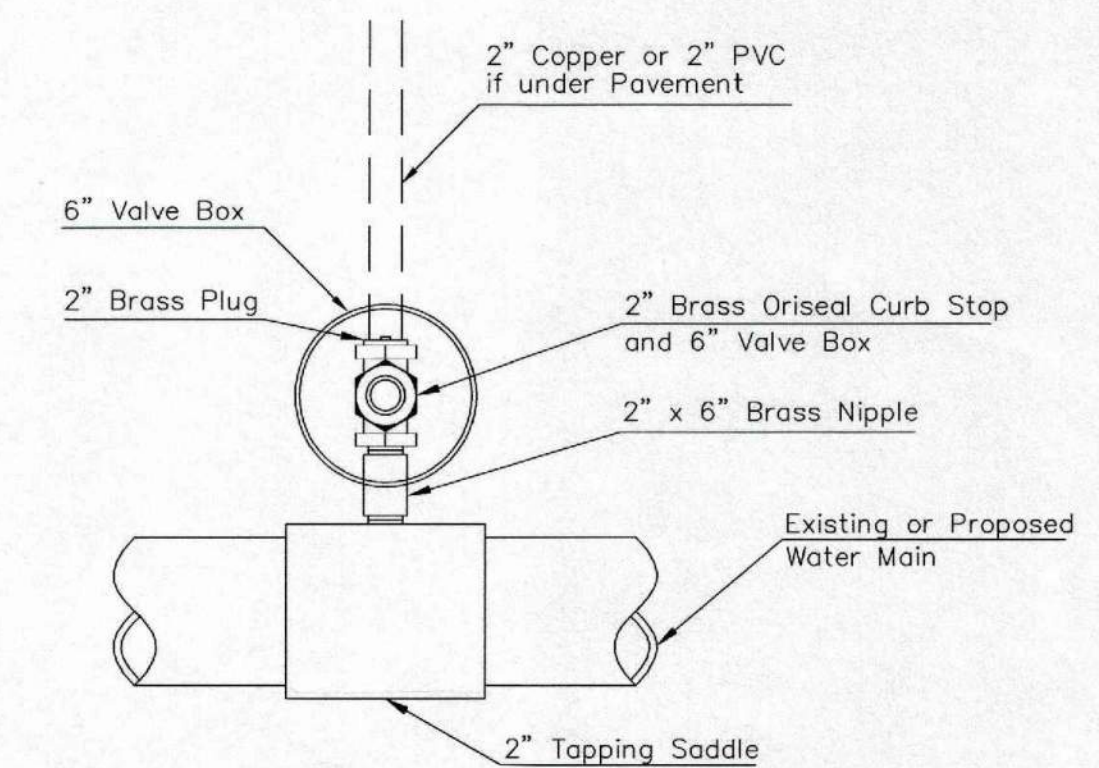

Note: Where the 2" Service Outlet Assembly is to be used to connect a 2" main to another main, the 2" valve shall be a 2" IPT Gate Valve. 2" ball or globe valves shall not be approved for this use.

2" SERVICE OUTLET ASSEMBLY

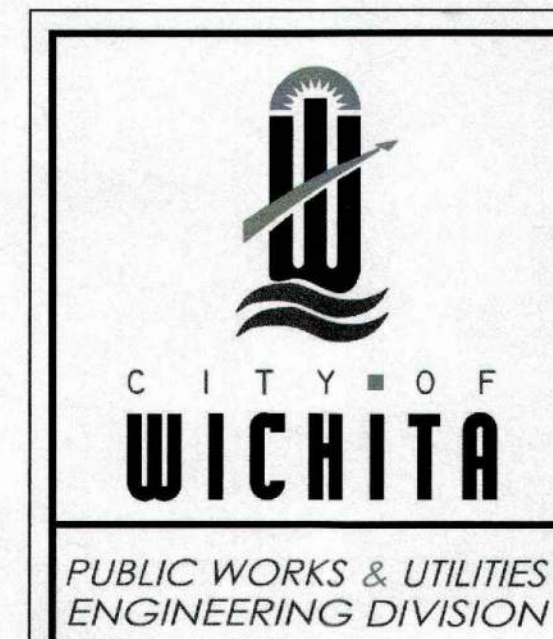

STANDARD WATER SERVICE DETAIL		
CITY ENGINEER GARY JANZEN, P.E.		
PROJECT NUMBER 448-90821	OCA NUMBER 637410	DATE 01/2013
CITY ENGINEER'S OFFICE CITY HALL - SEVENTH FLOOR 455 NORTH MAIN STREET WICHITA, KANSAS 67202-1620 (316) 268-4501		SHEET 19 of 26