

Combined Curb & Gutter (6")

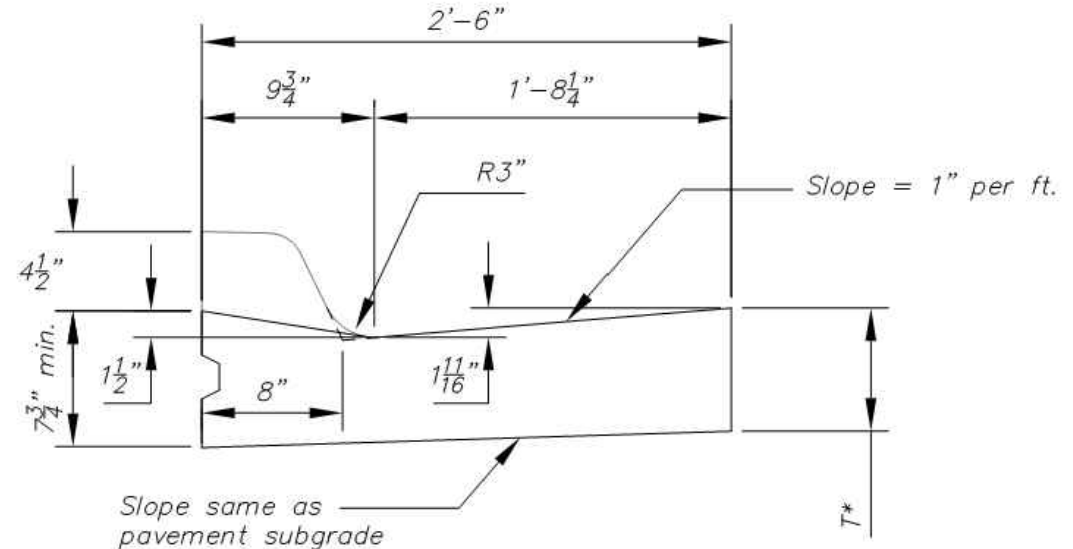

Combined Curb & Gutter (1 1/2")

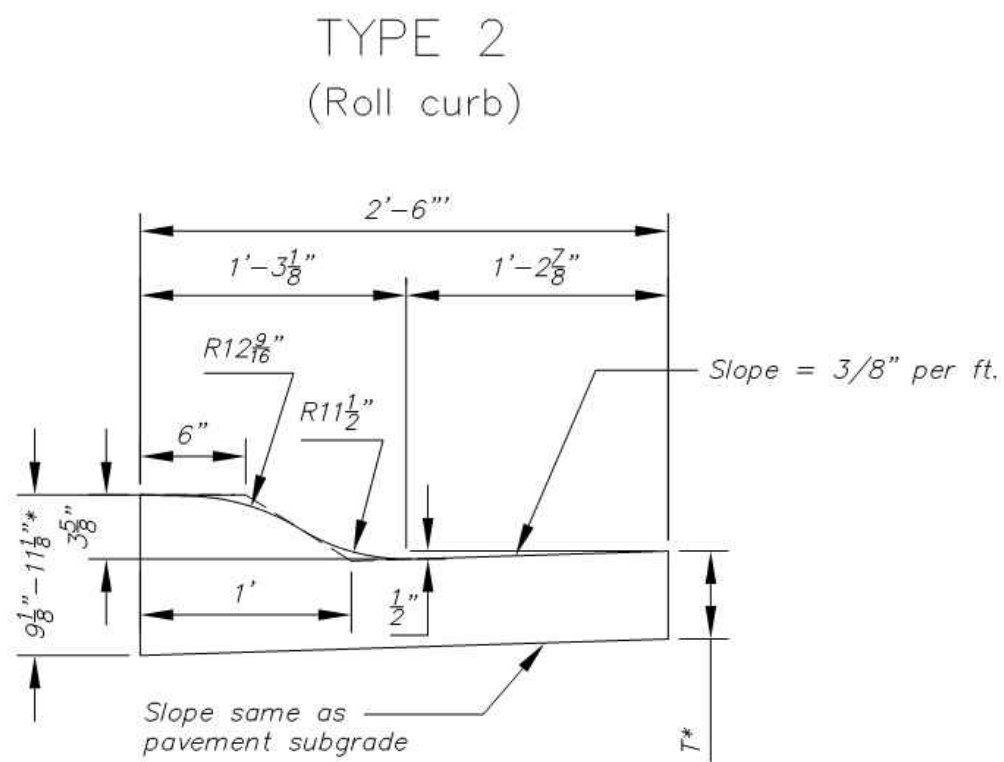

Combined Curb & Gutter (3 5/8")

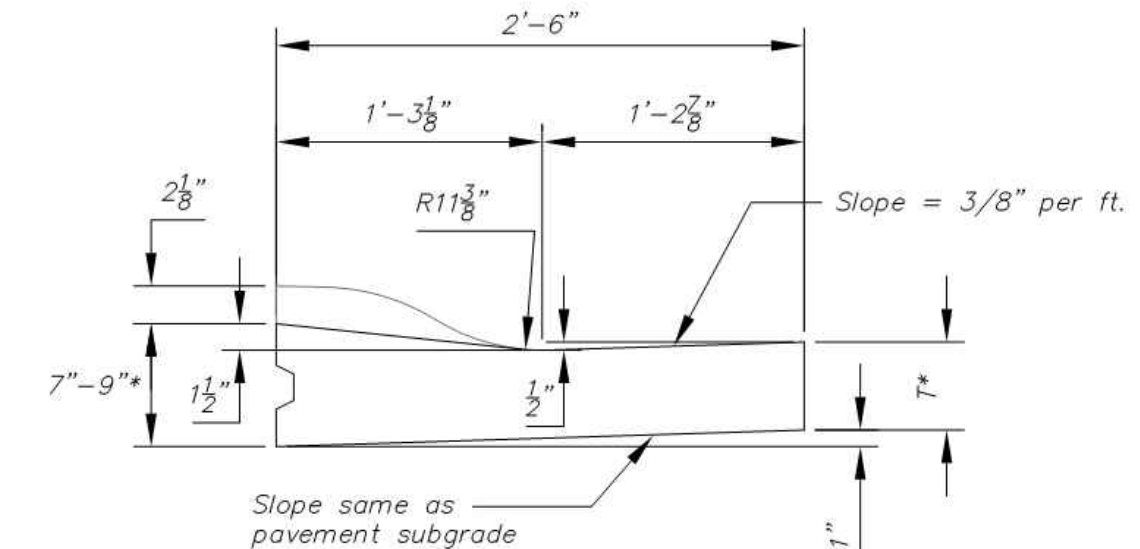

Combined Curb & Gutter (1 1/2")

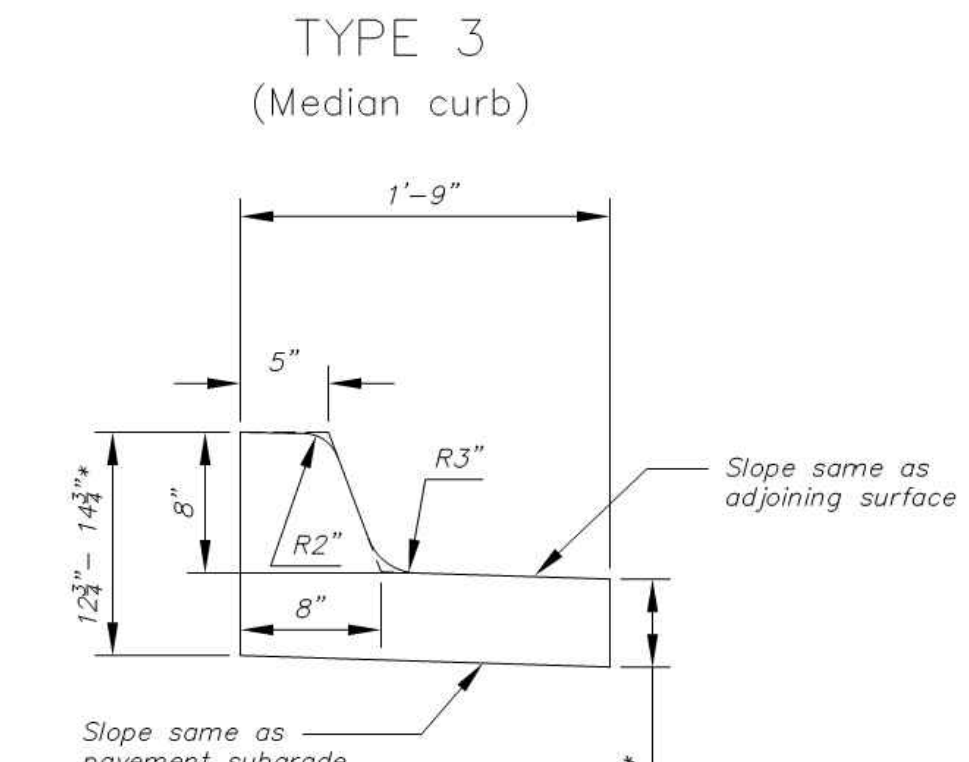

Combined Curb & Gutter (8")

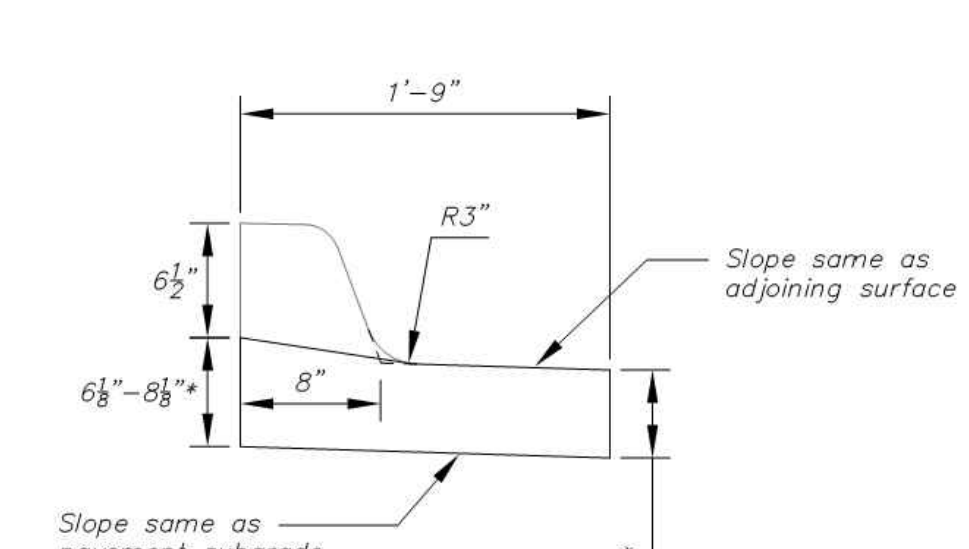

Combined Curb & Gutter (1 1/2")

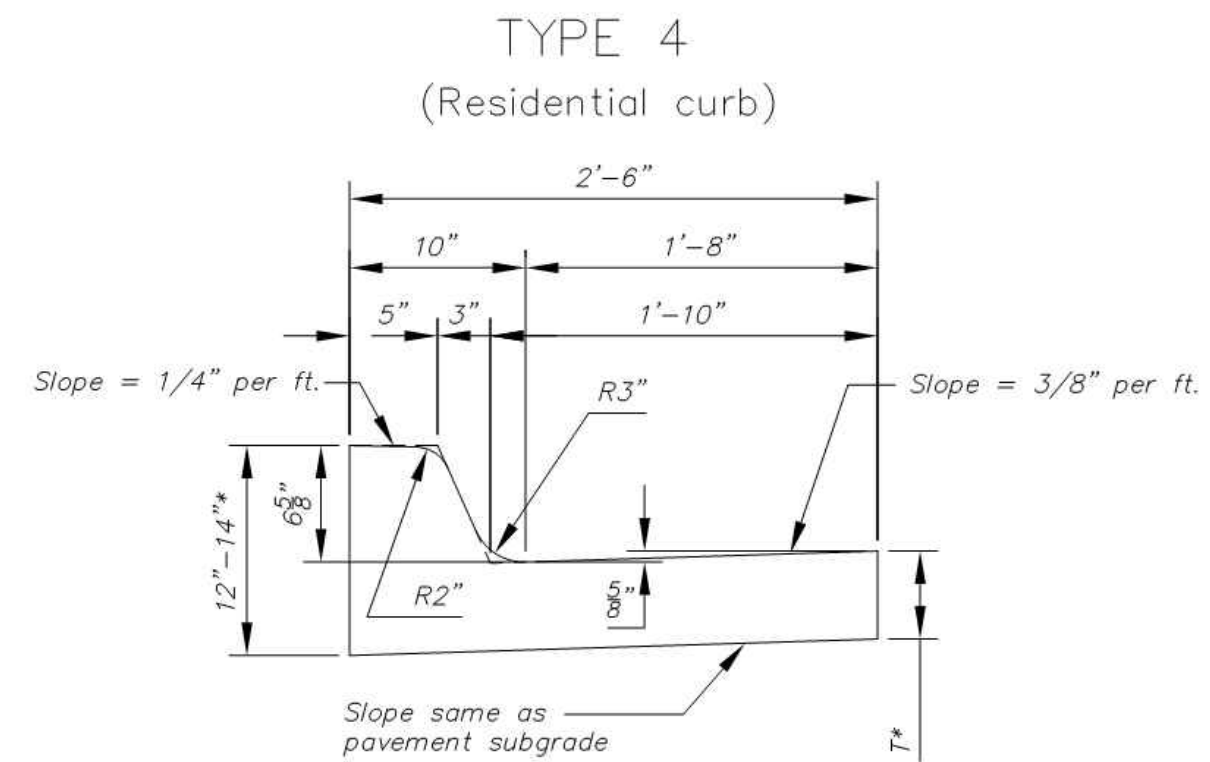

Combined Curb & Gutter (6 5/8")

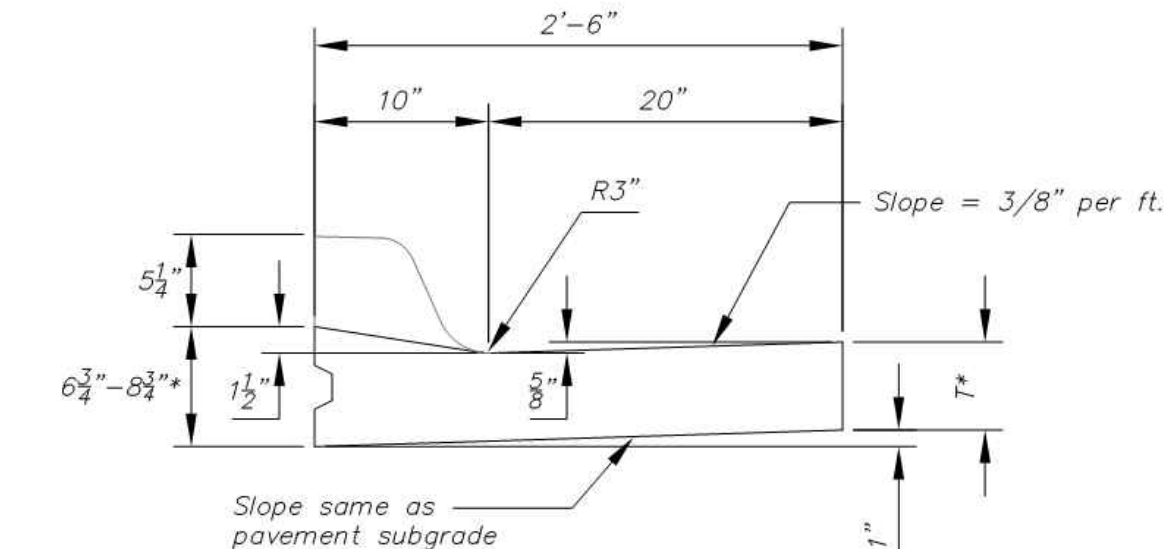

Combined Curb & Gutter (1 1/2")

T* = Thickness of curb to adjust with pavement thickness

GENERAL NOTES

- Expansion (isolation) joints shall be constructed a maximum of 300' apart and at all PIs, PCs, cul-de-sac quadrants, and ends of returns.
- Contraction joints shall be constructed a minimum of 12' apart.
- Joint sealer shall be required at all joints on arterial and industrial streets and at intersections on residential streets.

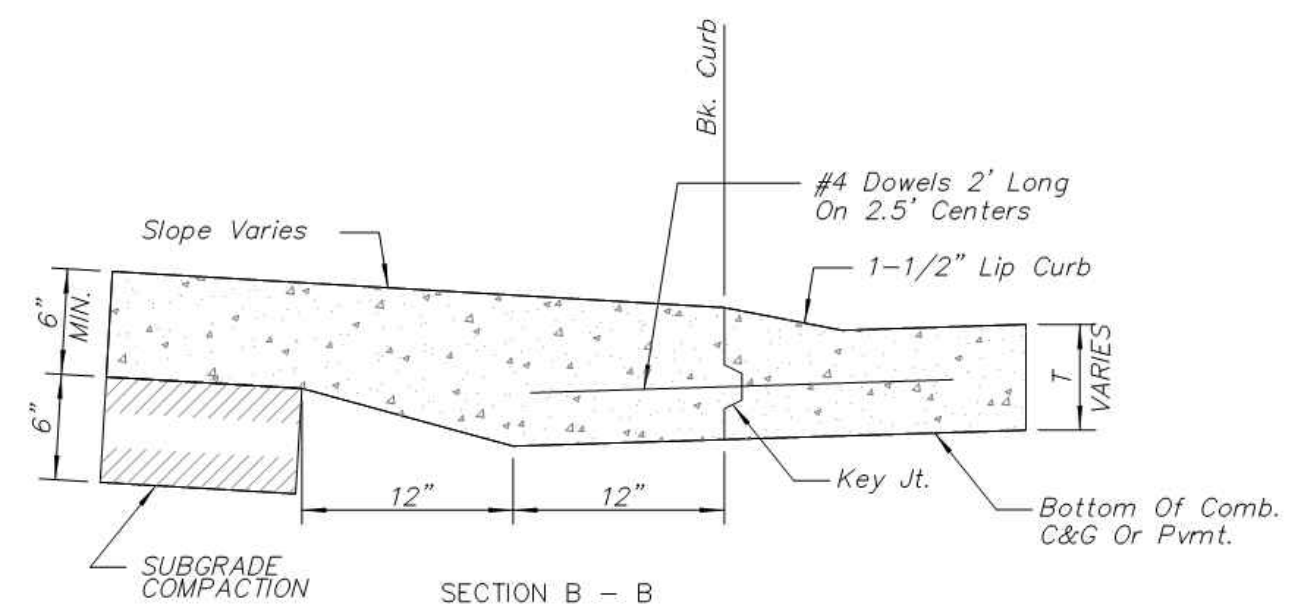

SECTION B - B
BACK OF CURB DETAIL

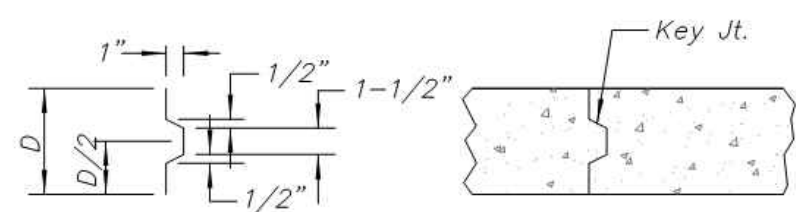

ALT. LONGITUDINAL CONSTRUCTION JOINT

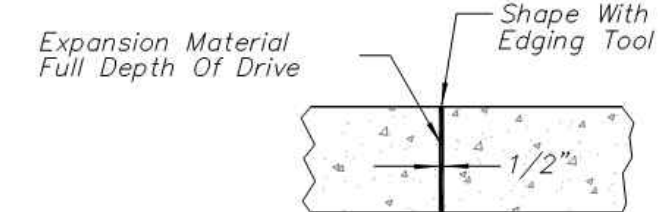

EXPANSION JOINT (E.J.)

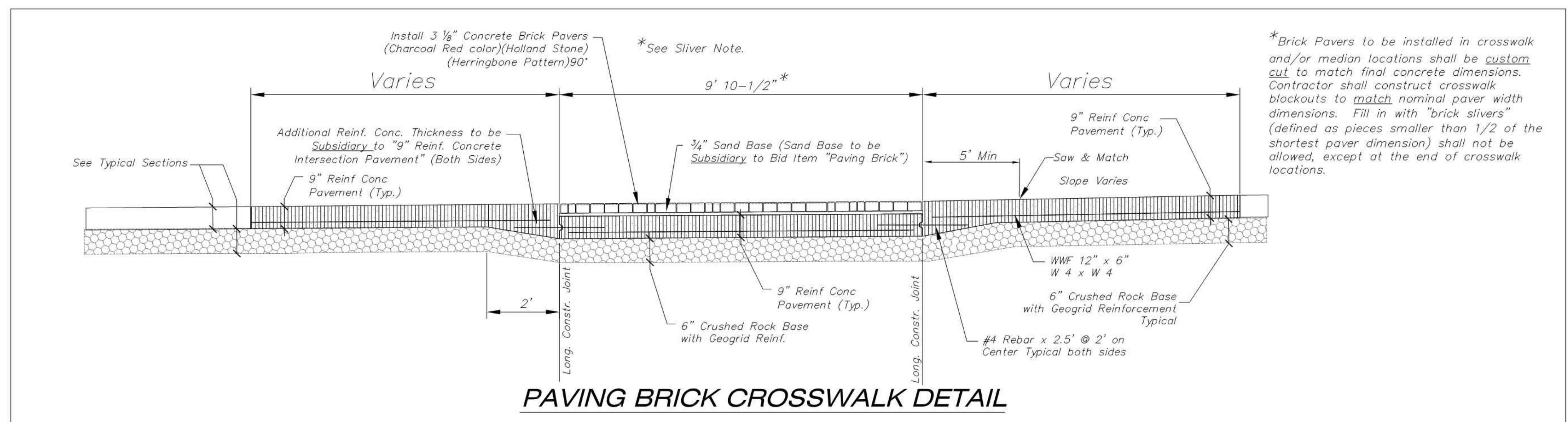

PAVING BRICK CROSSWALK DETAIL



REVISED: OCTOBER 2015		
CURB & GUTTER & PAVING BRICK CROSSWALK DETAILS		
CITY ENGINEER GARY JANZEN, P.E.		
PROJECT NUMBER	OCA NUMBER	DATE
CITY ENGINEER'S OFFICE CITY HALL - SEVENTH FLOOR 455 NORTH MAIN STREET WICHITA, KANSAS 67202-1620 (316) 268-4501		SHEET

TWIN LAKES TURN LANE
AMIDON AVE
WICHITA, KS
TWIN LAKES TURN LANE
PAVING DETAILS

PROJ. NO.	0221
DESIGNER	BAC
DRAWN BY	MLT
CFN	
SHEET	0221STDET
REV	
05 OF 13	0

BAC	MLT	BAC	MLT	BAC	MLT	BAC	MLT
DSN	DWN	CHK					

FOR CONSTRUCTION	9-11-19	DATE	
FOR CITY REVIEW	8-08-19	REV	A
DESCRIPTION			

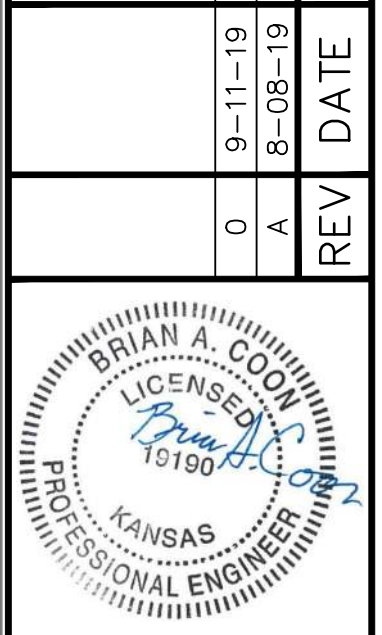

BRIAN A. COON
ENGINEER
KS # 19190

200 N. EMPORIA, SUITE 100
WICHITA, KANSAS 67203-4400-4309
PH: (316) 268-4501
www.kawvalley.com | www.kveing.com

KAW VALLEY ENGINEERING

KAW VALLEY ENGINEERING, INC. IS AUTHORIZED TO OFFER ENGINEERING SERVICES IN KANSAS STATE CERTIFICATE OF AUTHORIZATION # E-113. EXPIRES 12/31/20