

Use Keystone "No-Weld Number 1 Anti-Seize Compound" on all bolts & nuts.

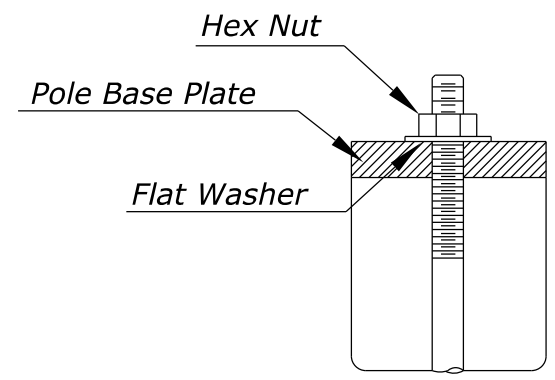

**ANCHOR BOLT
DETAIL**

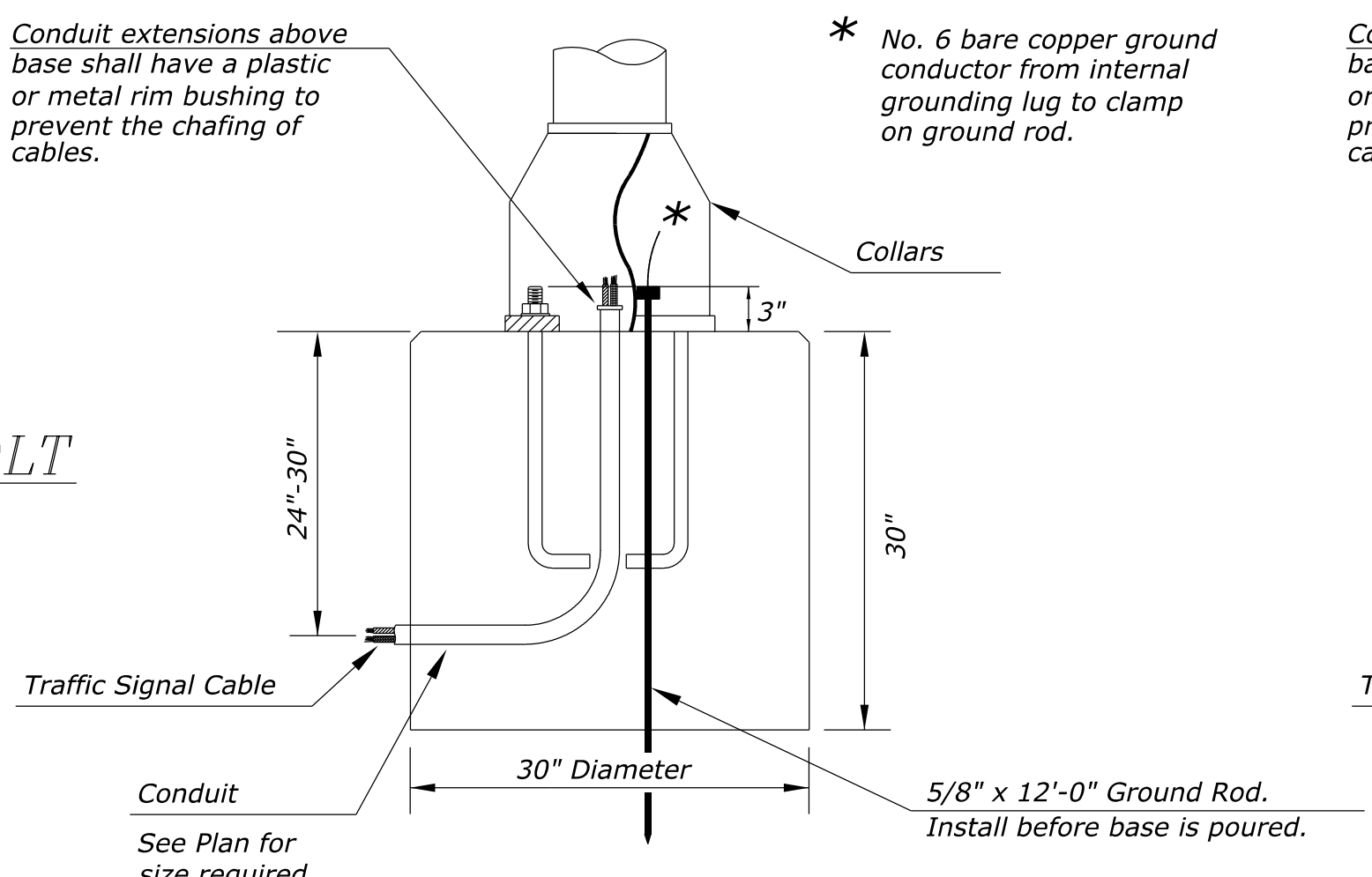
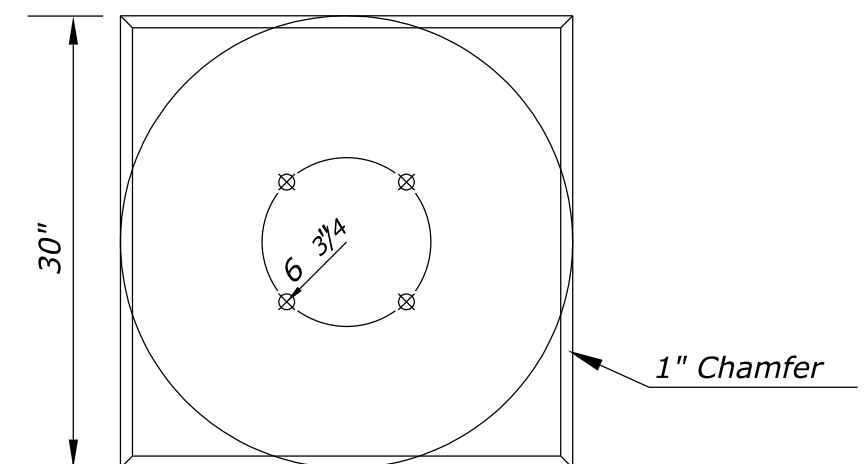

CONCRETE BASE-A DETAIL

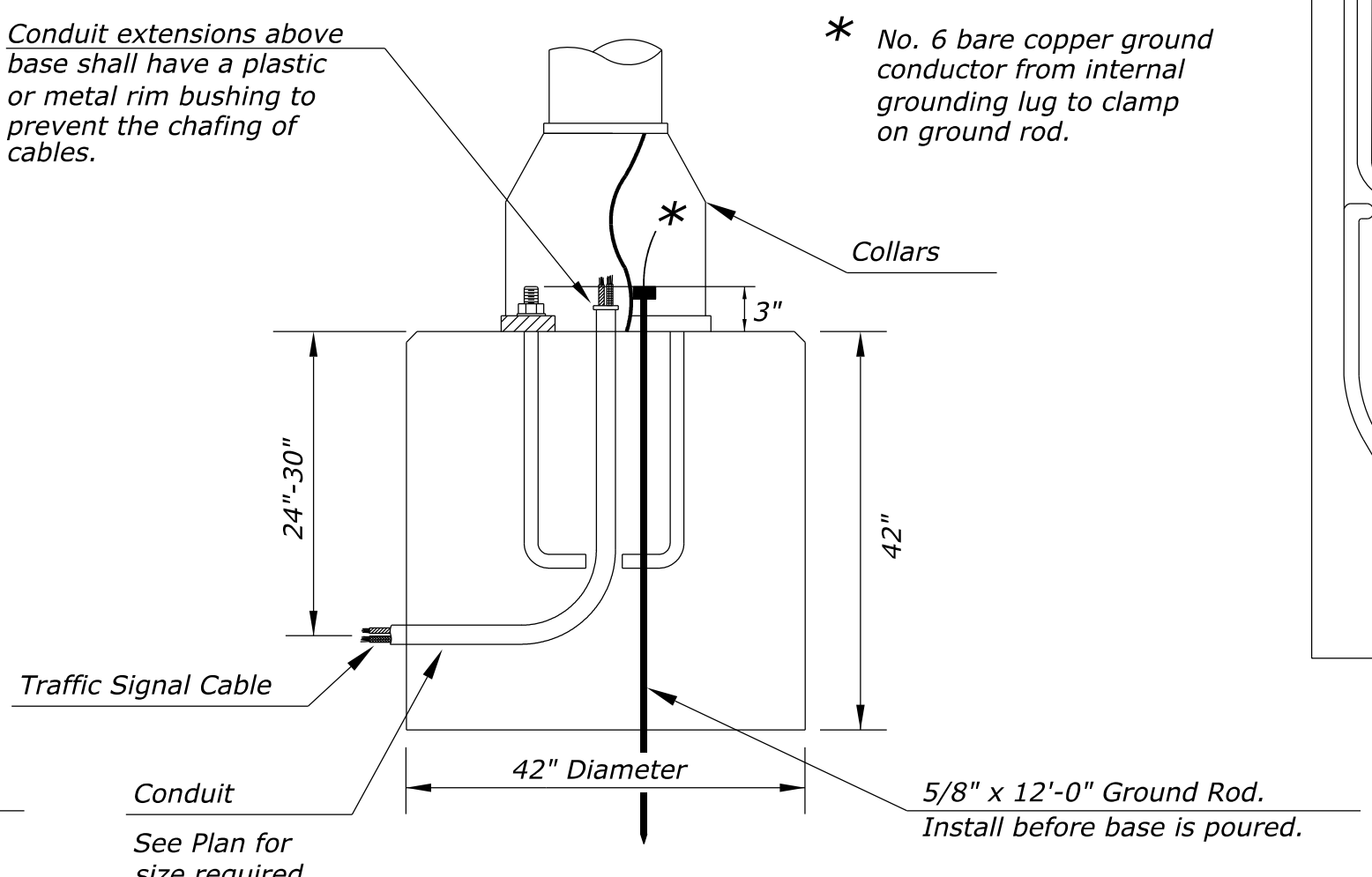
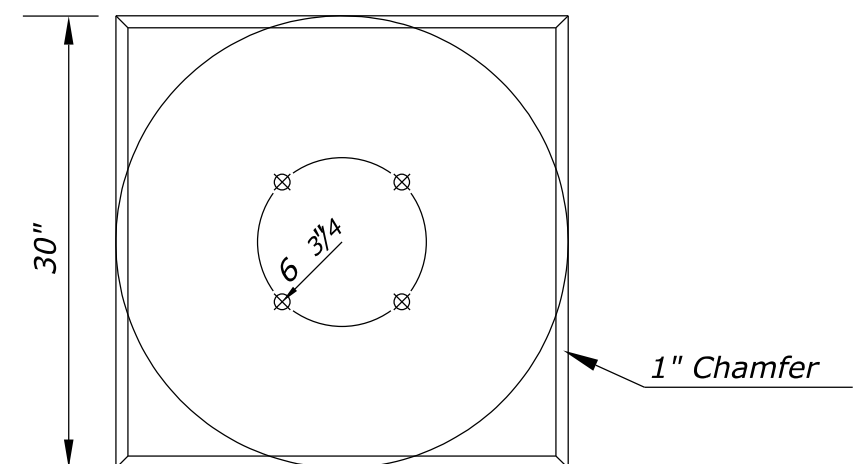

**CONCRETE BASE-B DETAIL FOR
TRAFFIC SIGNAL PEDESTAL
WITH CONTROLLER CABINET**

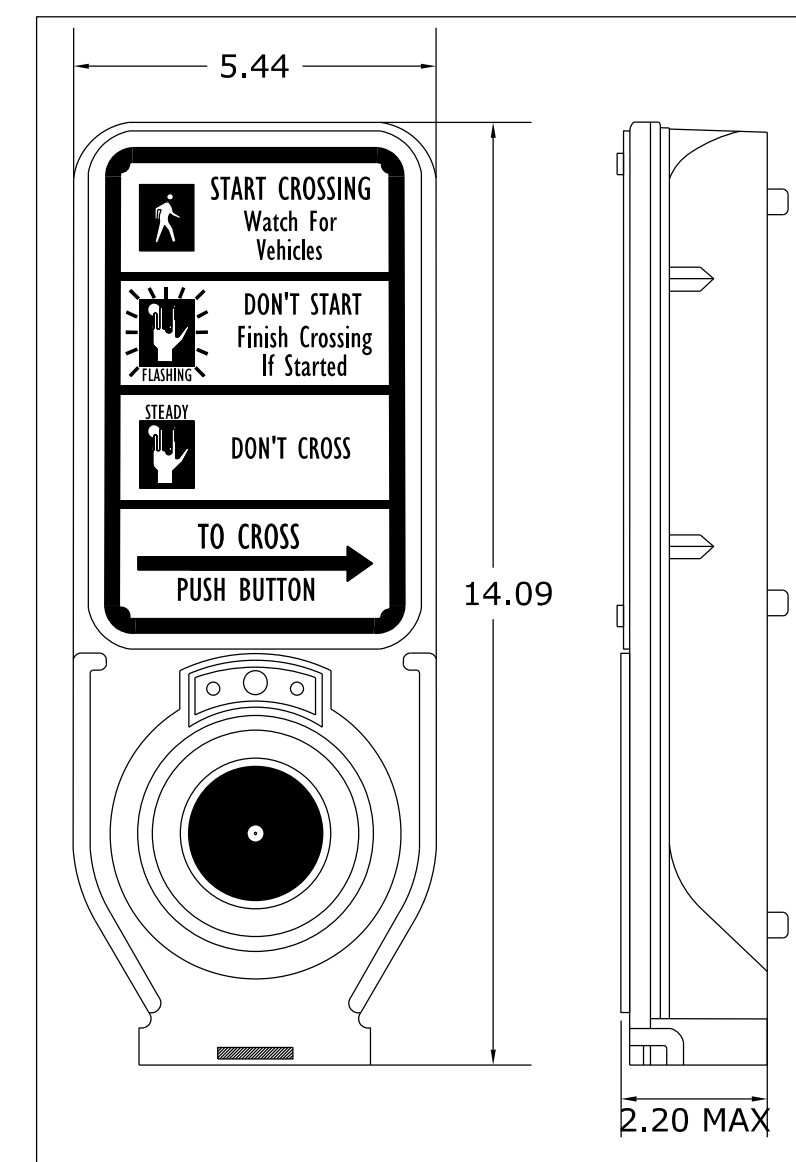

PUSH BUTTON STATION

DWG. NO. N45AN0-X

The 4 Wire Navigator PBS is the pedestrian interface to the Navigator Accessible Pedestrian Signal. All sounds emanate from the back of the unit via a weather-proof speaker that is protected by a vandal resistant screen. A sunlight visible LED latches "ON" to confirm the button has been pushed. Each PBS connects to a Control Unit located inside its associated ped sign housing. A four wire cable connects the PBS to the power unit.

PBS includes the Frame with Option "B" sign, ADA compliant push button, and mounting hardware.

By interfacing with the Control Unit that installs in the Pedestrian Walk Sign, the PBS shall provide the following standard features.

- * Conformation of the button push via latching LED, sound, and vibrotactile bounce.
- * Direction of travel (with extended button push).
- * Standard locating tone during Don't Walk (and clearance if desired).
- * Standard voice message during Walk.
- * Vibrating button during Walk.
- * Standard verbal countdown during PED clearance.
- * All sounds automatically adjust to ambient over 60db range.

**PEDESTRIAN PUSHBUTTON/SIGN
UNIT DETAIL**

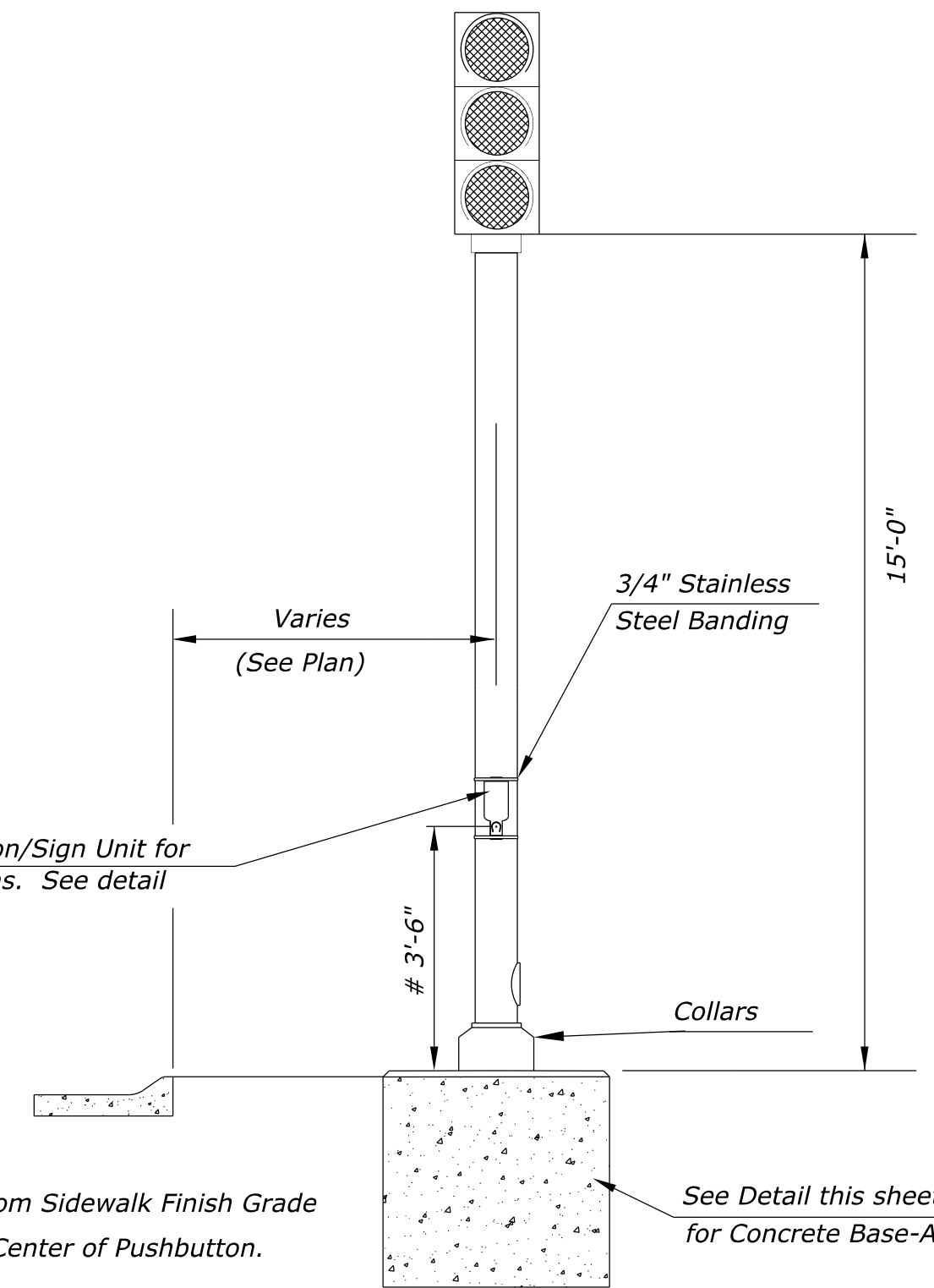

TRAFFIC SIGNAL PEDESTAL

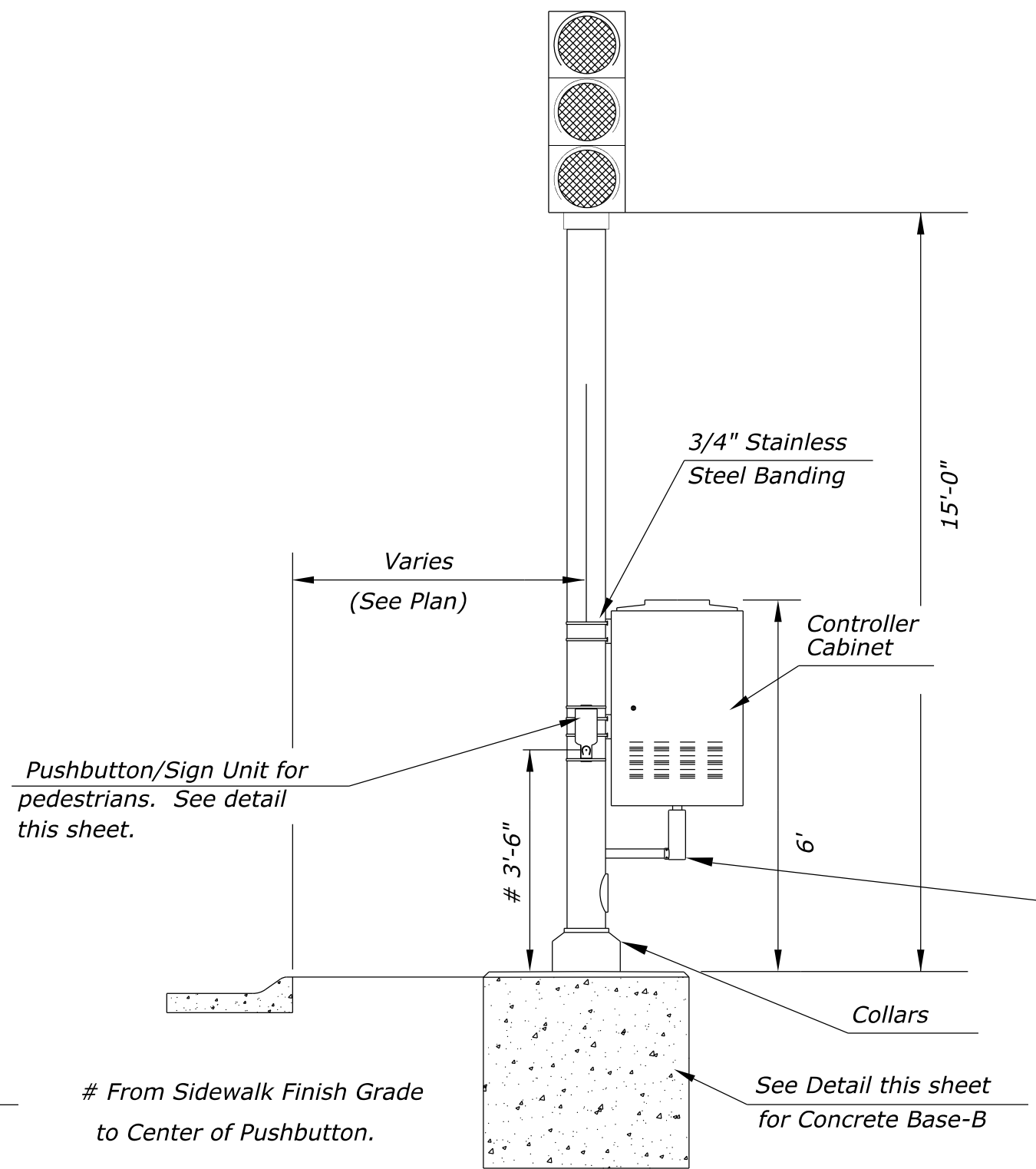

**TRAFFIC SIGNAL PEDESTAL
WITH CONTROLLER CABINET**

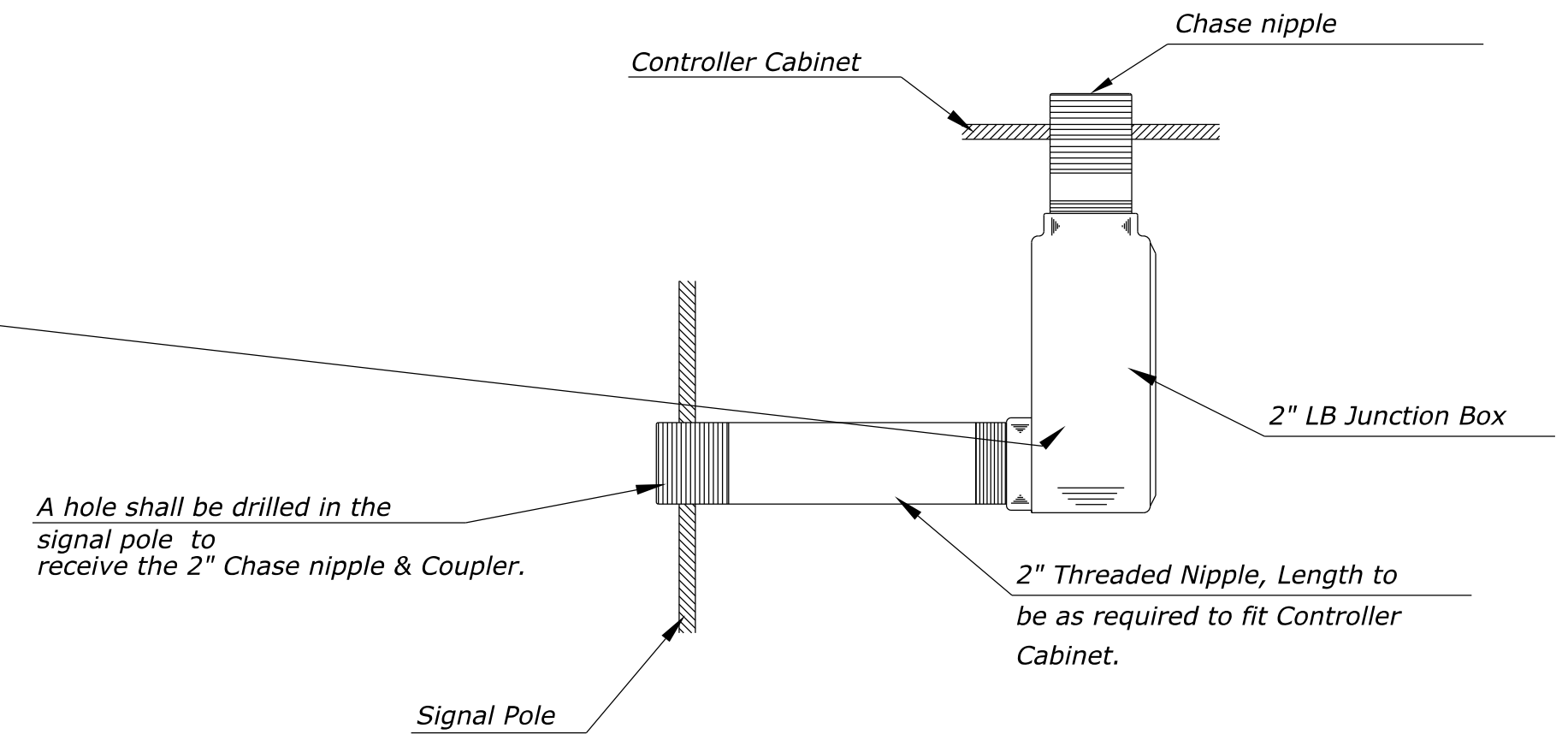

A hole shall be drilled in the signal pole to receive the 2" Chase nipple & Coupler.

PUSH BUTTON STATION

Message and Sound options include:

- * Locating tone
- * Verbal Street Name (Example: Crossing Main at Central)
- * All features field selectable using a Configurator.

Construction :

- * Die-cast aluminum, powder coated Black in color.
- * Street Name in Braille in the directional arrow of the sign.
- * Option "B" signing option.

Push button :

- * ADA compliant
- * Raised tactile arrow on the button
- * Solid State switch rated at a Minimum of 20 million actuations

PLATE MARKING OPTIONS

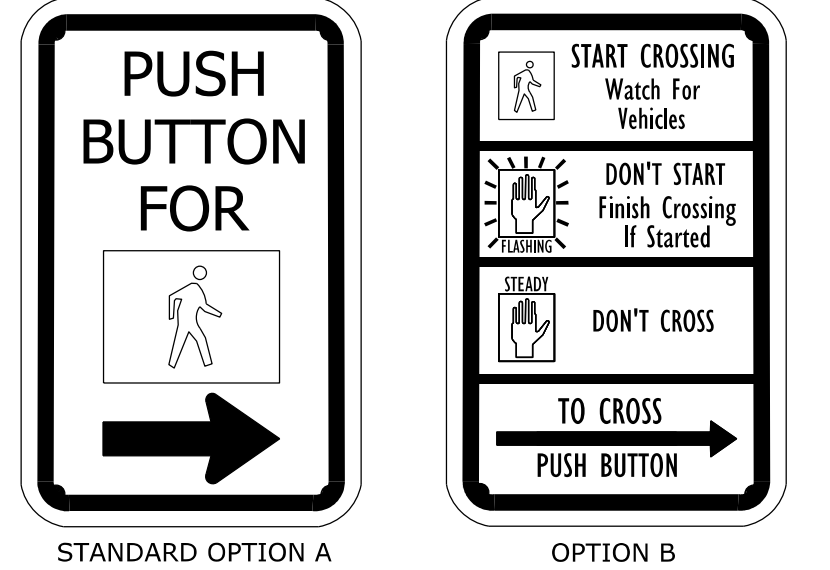

DWG. NO. N45AN0-X



**SIGNAL PEDESTAL & BASE
WITH ADA PUSH BUTTON**

TRAFFIC ENGINEER

PROJECT NUMBER	OCA NUMBER	DATE
472-85359	715735	.
CITY ENGINEER'S OFFICE		SHEET
CITY HALL - SEVENTH FLOOR 455 NORTH MAIN STREET WICHITA, KANSAS 67202-1620 (316) 268-4501		103 of 135

REVISED: AUGUST 2014