

STATE	PROJECT NO.	YEAR	SHEET NO.	TOTAL SHEETS
KANSAS	87 TE-0451-01	2018	36	222

GENERAL NOTE

Epoxy coat all deformed tie bars that are straight. Patch any damage to the epoxy coating in accordance with the Standard Specifications. Use billet steel Grade 40 reinforcing for deformed tie bars that require bending, may be epoxy coated at the Contractor's option. Place pressure relief joint at the end of the bridge approach pavement slab (no bars through joint). For details of pressure relief joint see Standard Drawing RD712. Use load transfer devices as shown in details at all construction joints on mainline pavement unless otherwise noted. Shoulder contraction joints have no dowels unless specifically shown on the plans.

◆ Fill all sawed joints on the project in accordance with the Standard Specifications with the exception of those joints in pavement constructed over Cement or Asphalt Treated Base.

✱ Use single saw cut, 1/8" wide, joint in pavement constructed over Cement or Asphalt Treated Base (Non-Sealed Joint Sawcut). Use single saw cut, 1/2" wide, joint for shoulder pavement adjacent to mainline pavement constructed over Asphalt or Cement Treated Base (Non-Sealed Joint Sawcut). See detail this sheet.

Shape all keyed joints similar to section of recessed form leg as shown on this sheet.

Evenly space tie bars along the length of slab with no tie bar within 12" of contraction joint. All longitudinal joints are tied.

Shoulder rumble strips will not be constructed as part of this project.

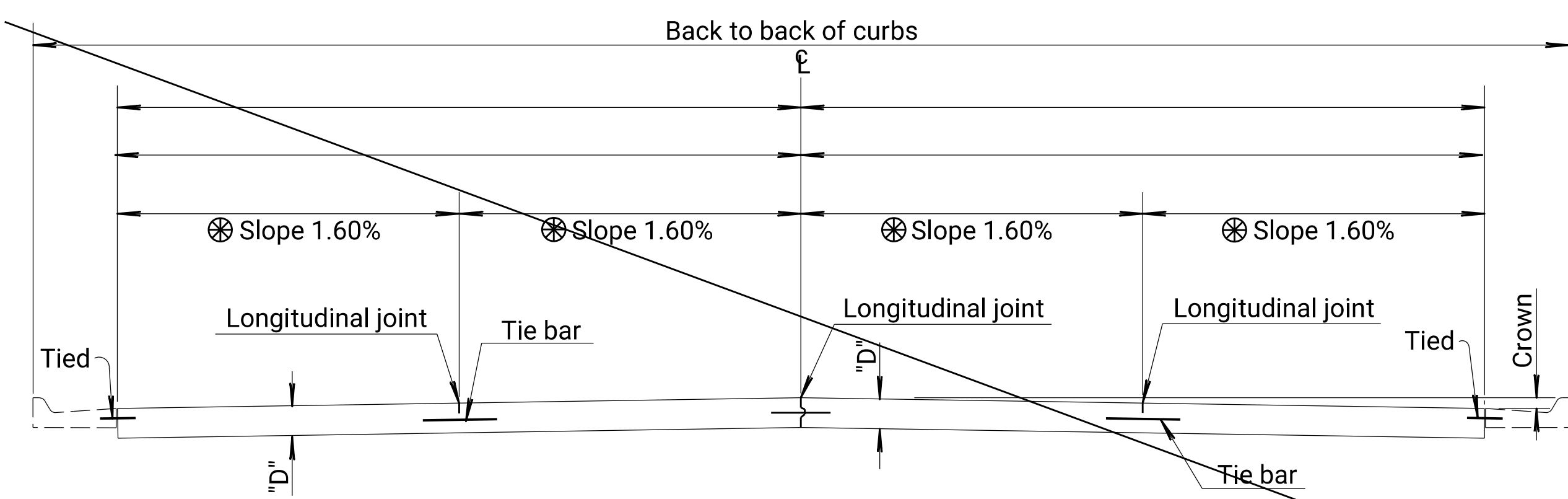

**TRANSVERSE SECTION
(4-LANE WITH CURB & GUTTER)**

For Curb & Gutter details See Standard Drawing RD635.

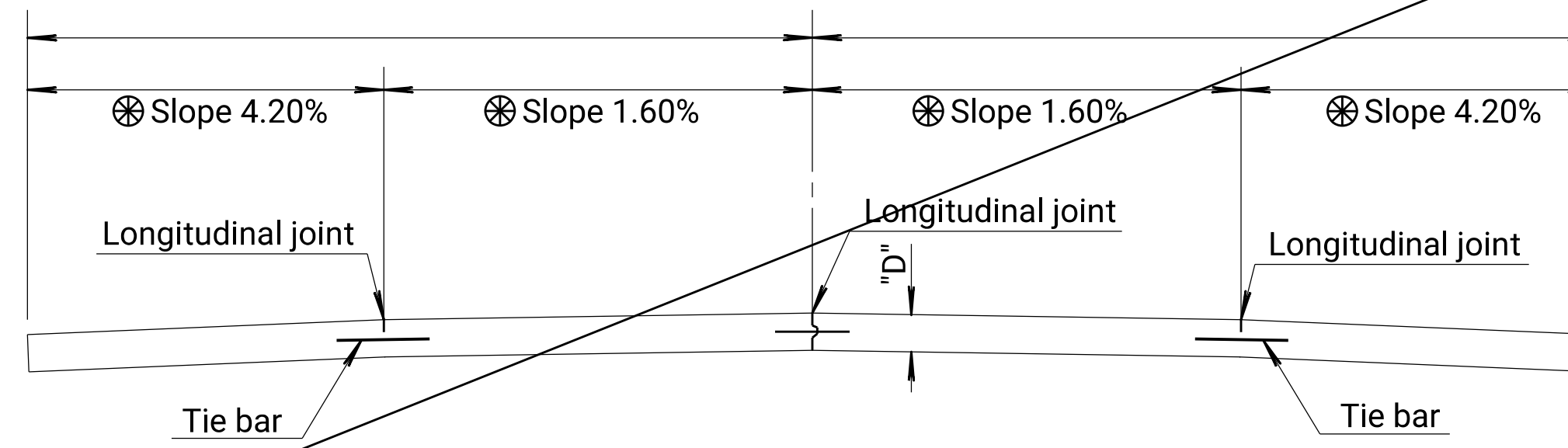

**TRANSVERSE SECTION
(2-LANE WITH SHOULDERS)**

⊗ Normal cross slopes. See Typical Section or Cross Sections for variations.

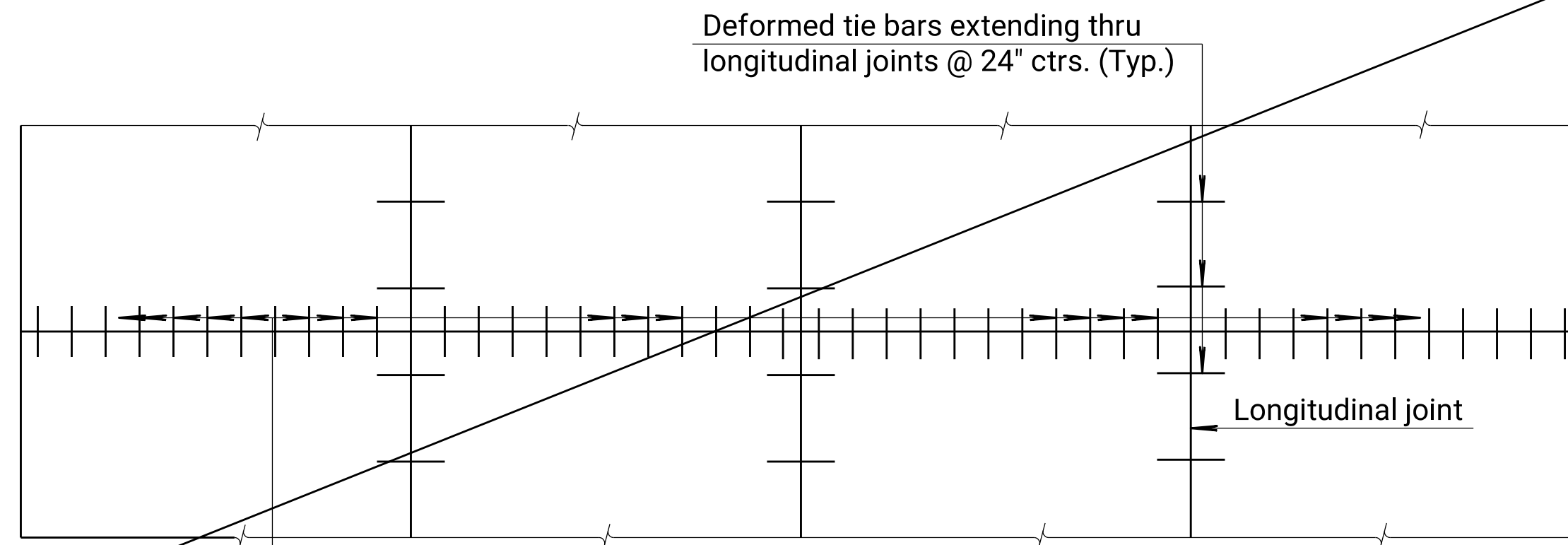

**PLAN
(4-LANE WITH CURB & GUTTER)**

∅ x 18" Smooth Dowel bars
Dowel bars @ 12" ctrs. thru contraction joint (Typical).

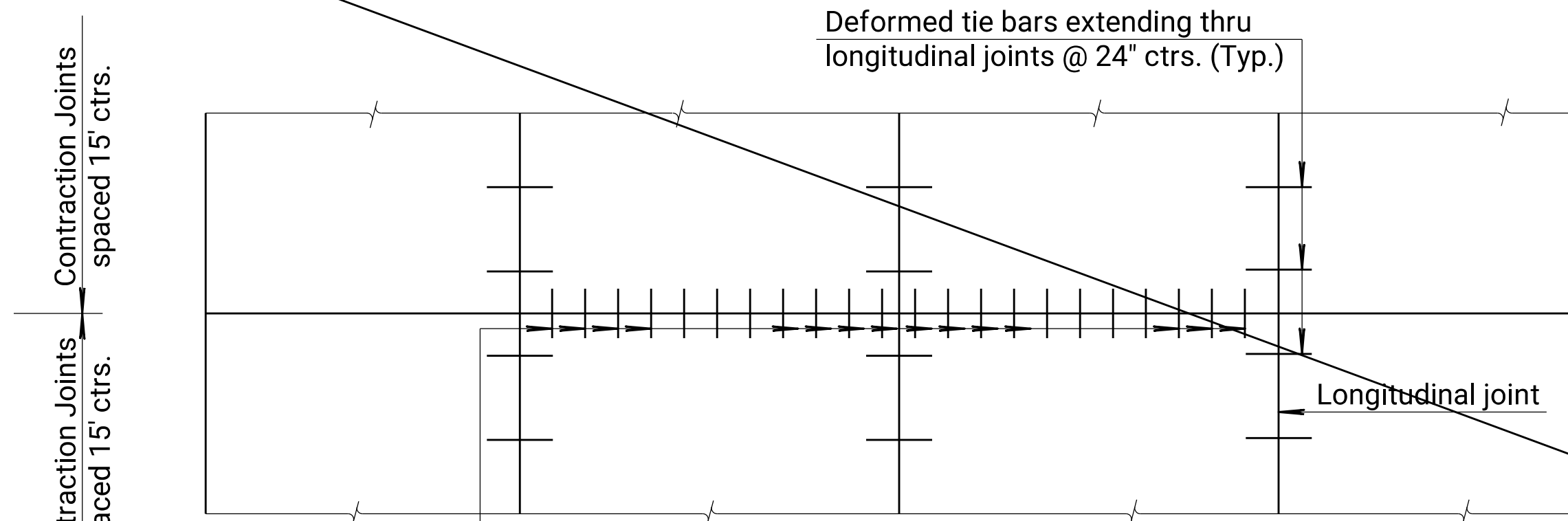

**PLAN
(2-LANE WITH SHOULDERS)**

∅ x 18" Smooth Dowel bars
Dowel bars @ 12" ctrs. thru contraction joint (Typical).

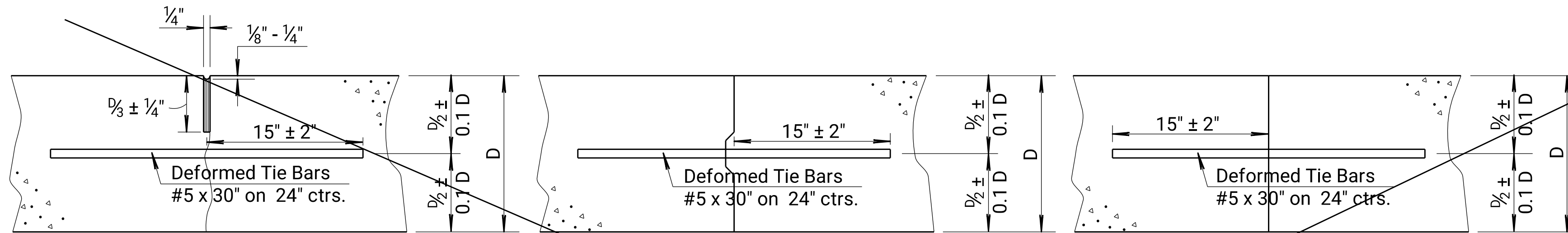

LONGITUDINAL JOINTS

Note: For longitudinal construction joints the contractor has the option of using either the keyed or butt type. Place deformed tie bars mid-depth of the shoulder.

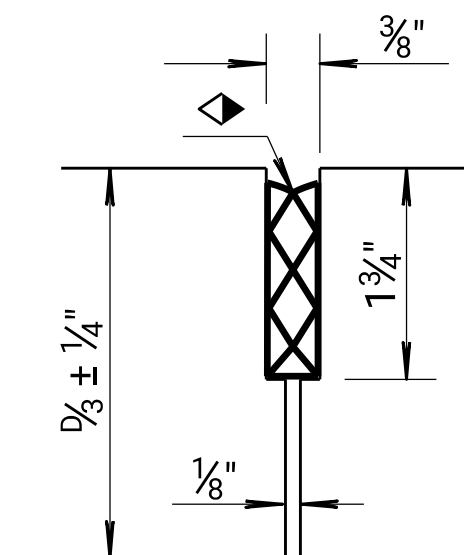

DETAIL OF SEALED JOINT SAWCUT

Make an initial 1/8" saw cut (2/3 ± 1/4" depth); the second 3/8" saw cut is a separate operation done after concrete has gained sufficient strength to avoid spalling as determined by the Engineer.

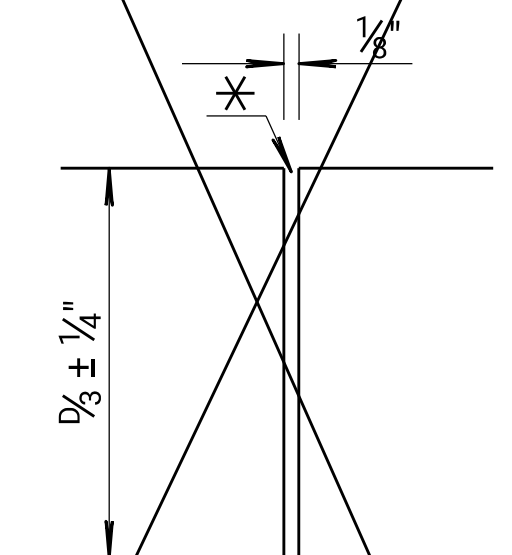

DETAIL OF NON-SEALED JOINT SAWCUT

Make only the initial 1/8" saw cut after concrete has gained sufficient strength to avoid spalling as determined by the Engineer.

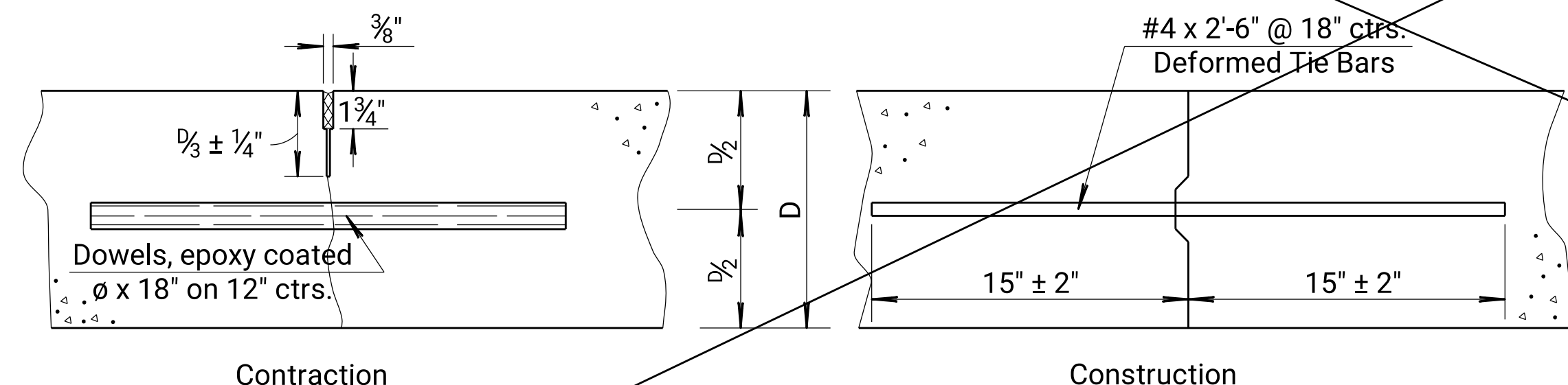

TRANSVERSE JOINTS

Note: Construct contraction joints at plan locations or at the Engineer's direction. When necessary to interrupt continuous placement for a substantial length of time or at the end of a day's paving, the Contractor has the option of ending placement at a contraction joint or with a construction joint located a minimum of five (5) feet from a contraction joint. Construct either joint type by placing a header at the end of the pour or by paving past the joint location. After the concrete has hardened, saw joint and drill holes for tie bars or dowels.

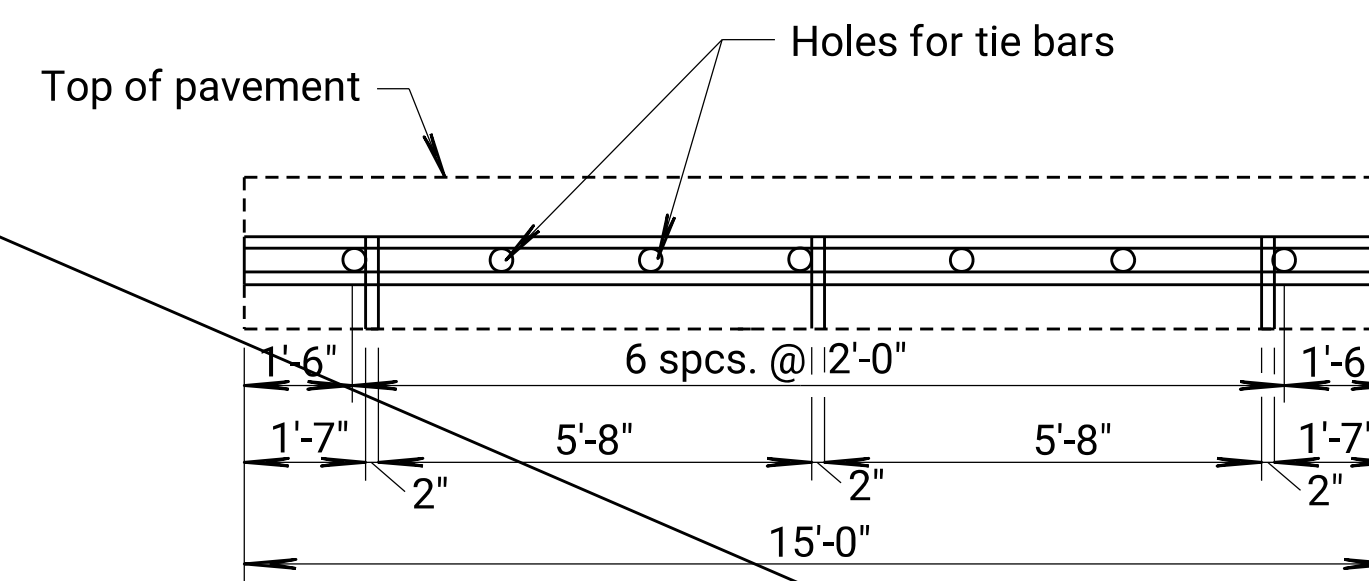

METAL STRIP FOR LONGITUDINAL CONSTRUCTION JOINT

To be used only against forms, do not extend through contraction joints. For automated placement tie bars are spaced at uniform 24" centers. ☆ Use snap-in leg or other approved design in lieu of welded leg.

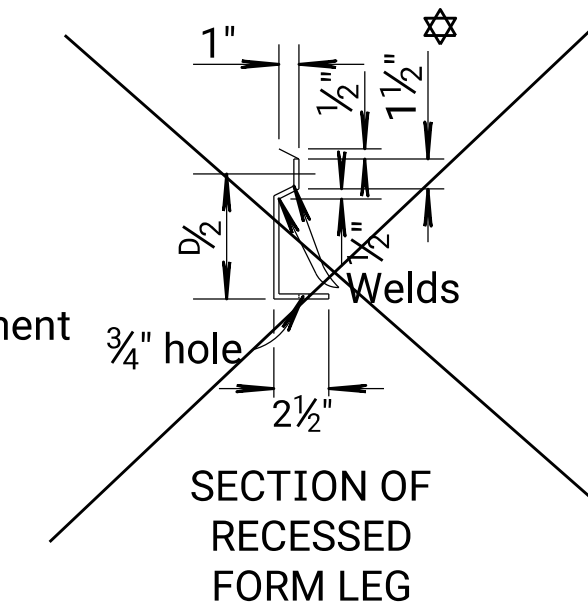

SECTION OF RECESSED FORM LEG

DOWEL SIZE	
D (in.)	Diameter
6 < D < 9	1"
9 ≤ D < 11	1 1/4"
D ≥ 11	1 1/2"

PAVEMENT DEPTH

D=

Note: Designer to add applicable dowel sizes.

Drawn By: \$\$\$USERNAME\$\$\$ Plotted \$\$\$SYTIME\$\$\$
File: \$\$\$SDGN\$\$\$SPEC\$

19	5-17-13	Revised Note, Longitudinal Joints	S.W.K.	J.O.B.
18	3-21-12	Revised Table, Dowel Size	S.W.K.	J.O.B.
17	1-9-12	Added Detail, Non Sealed Joint	S.W.K.	J.O.B.
16	8-18-10	Revised Dowel Size & Notes	S.W.K.	J.O.B.
NO.	DATE	REVISIONS	BY	APPD

KANSAS DEPARTMENT OF TRANSPORTATION

**CONCRETE PAVEMENT
DOWEL JOINTED
NON-REINFORCED**

RD708

FHWA APPROVAL	10-23-13	APPD.	James O. Brewer
DESIGNED	DETAILED	QUANTITIES	TRACED
DESIGN CK.	DETAIL CK.	QUAN. CK.	TRACE CK.

DOT Graphics Certified 03-29-2018