

GENERAL NOTES

Foundation Stabilization:
The depth of Foundation Stabilization may be increased by the Engineer. The Contractor may underrun Foundation Stabilization under the barrel if founded on firm material and with the Engineer's approval. Use Foundation Stabilization on all wingwalls unless founded on rock or granular material.

Granular Backfill (Wingwalls):

- Granular Backfill shall be used to backfill behind wingwalls to the limits shown in the WINGWALL PLAN and Elevation detail. Granular Backfill construction may be used separately or combined with Foundation Stabilization as directed by the Engineer.
- Measurement for the bid item, "Granular Backfill (Wingwalls)", shall be measured in Cubic Yards to the theoretical limits as shown.
- Material for Granular Backfill (Wingwalls) shall conform to the requirements of SB-1, SB-2, SCA-1 or SCA-2.
- Consolidate Granular Backfill using hand equipment only. Avoid over consolidation.
- Use filter fabric complying with Section 1710. Use only within the limits of Granular Backfill to separate from the In-Situ Material. Filter Fabric is subsidiary to "Granular Backfill".

In-Situ Backfill (Wingwalls):

- Use any material found within the project limits except Highly Plastic Clay(s) or organic material. The material is subsidiary to "Granular Backfill".
- Use Type "B" Compaction.
- Use only hand or walk behind equipment for Compaction.

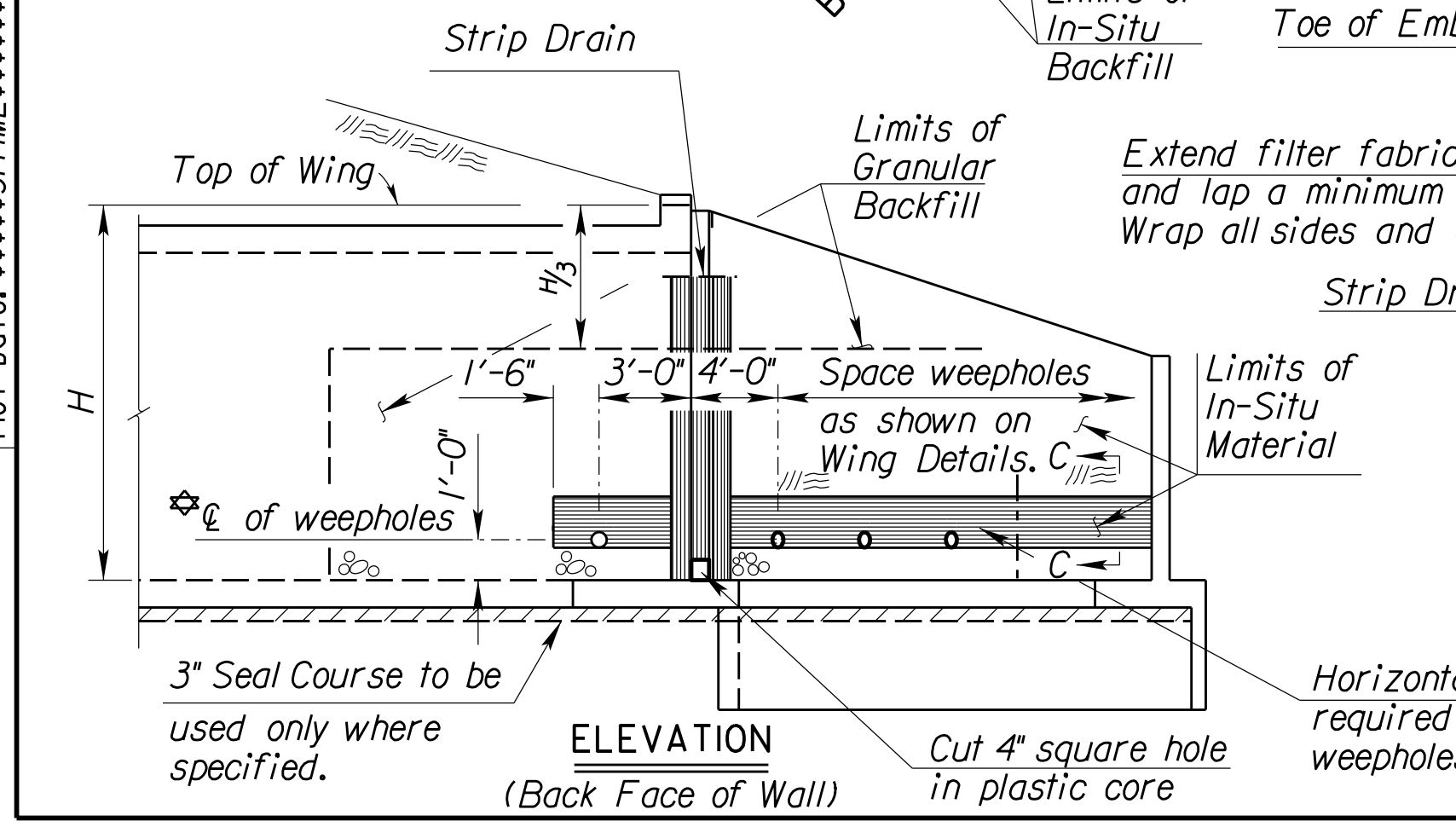

GENERAL NOTES

Wingwall Drainage:

- All wingwalls with weepholes shall have horizontal and vertical wingwall drainage as shown. Strip drains will be used. See KDOT Specifications for "Abutment Strip Drains" for strip drain requirements.
- Construction and materials for wingwall drainage, including weepholes, and strip drain shall be subsidiary to the bid item, "Grade 4.0 Concrete". Weepholes may be a formed opening or corrugated polyethylene tubing.

Wingwall Foundation Stabilization:
The Foundation Stabilization quantity has been calculated to the limits shown in the Section Thru Wingwall. The depth may be increased by the Engineer. Use Foundation Stabilization on all wingwalls unless founded on rock or granular material.

Seal Course:

- Seal Course consisting of 3" min. of Commercial Grade Concrete shall be constructed to the limits directed by the Engineer. No reinforcing in the floor of the slab or wall footing shall be placed until the Seal Course has gained sufficient strength to permit working upon it without injury.

GENERAL NOTES

Bridge Backwall Protection System:

- For all structures with less than or equal to 2'-0" of fill, apply a "Bridge Backwall Protection System" from Section 1700 to the limits shown. Do not place hot mix asphalt directly on this material.
- Use a "non-coal tar" material from KDOT's approved list.
- Protect this material from damage during backfilling. Repair at no additional cost.
- When the Plans show hot mix asphalt placed directly on the slab, substitute "Pavement Water Proofing" material from Section 800, this material shall be subsidiary. Wait 28 days after top slab is completed before applying this material.

NO.	DATE	REVISIONS	BY	APP'D
7	2/6/18	Filter Fabric Clarification	MLL	JPJ
6	6/7/17	Filter Fabric Modification	JPJ	JPJ
5	10/11/13	Granular Backfill Limits	JPJ	LRR
4	10/11/12	Added Weep Hole Note	JPJ	TLF
3	8/2/12	Modified Backwall Notes	JPJ	TLF
2	3/7/12	Added Filter Fabric to Detail	JPJ	TLF
1	12/15/11	Added Bridge Backwall Protection	JPJ	TLF

KANSAS DEPARTMENT OF TRANSPORTATION

RCB AUXILIARY DETAILS (LRFD)

BR020B

DESIGNED	JPJ	DETAILED	JPJ	QUANTITIES	CAA	RAA
DESIGN CK.	JSR	DETAIL CK.	JPJ	QUAN. CK.	CAA	JPJ

APPROVAL: 4/17/10 APP'D TERRY L. FLECK

FILED: 4/17/10 FILED TERRY L. FLECK

CADconform Certify This File

Std. Base File: br020.dgn
 Plotted By: \$USERNAME\$
 File: \$\$\$\$\$\$DGN\$SPEC\$\$\$\$\$
 Plot Date: \$\$\$\$STIME\$\$\$\$\$