

Sta. 154+11.84
 Remove Existing Bridge 2 - 16'-6"
 Reinf. Conc. Slab Spans (RCS) 11' Roadway
 N=1697228.76
 E=1694313.16

Sta. 154+12.00
 Construct 30' Pre-fabricated
 Weathering Steel Truss Bridge
 Conc. U-type Abutments on
 Pile Bent (Bearing) 12' Roadway
 N=1697228.76
 E=1694313.32

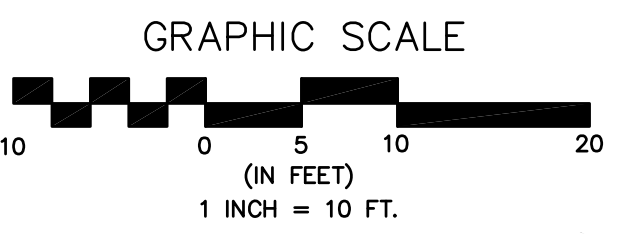

PLAN

EXISTING WATERWAY OPENING

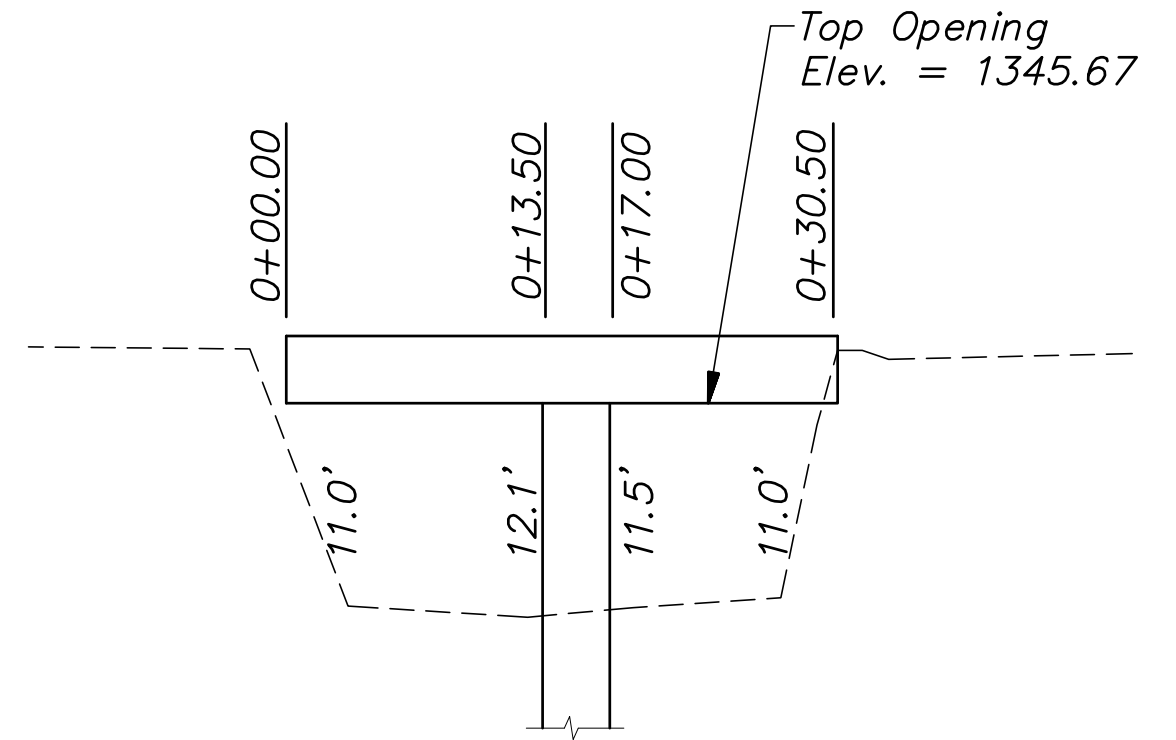

EXISTING RAILROAD BRIDGE
 over FOUR MILE CREEK
 Looking Upstream (North)

2 Spans @ 16'-6"
 Concrete Slab Spans
 0° Skew, 11'-0" Out-to-Out
 ± Sta. 154+11.84

EXISTING STRUCTURE

The Contractor shall remove the existing 11.0 ft. wide concrete deck and 2-16'-6" reinforced concrete slab spans, pier, and abutments. A portion of the limestone blocks from the existing bridge abutments shall be salvaged and used as landscaping blocks within the project. Remaining blocks to be stockpiled on-site as approved by the Engineer for future City use. Payment for removal and relocation of the blocks within the project will be paid as "Roadside Improvement", Lump Sum. All other items of the existing structure shall become the property of the Contractor and shall be removed from the site.

The Contractor shall excavate/fill the channel at the bridge site to the limits shown prior to construction of the bridge.

The Contractor shall complete the embankment as shown on the Bridge Excavation Sheet prior to construction of the bridge. All trees, hedge rows, shelterbelts, and woody shrubs not shown to be removed and located between the construction limits and the right-of-way line or easement lines shall be spared unless directed by the Engineer to be removed.

UTILITIES

- | | |
|---|---|
| <p>AT&T
 Jason Edwards
 154 N. Broadway, Rm 210
 Wichita, KS 67202
 (316)268-2008</p> | <p>Cox Communication
 James Walburn
 901 George Washington Blvd.
 Wichita, KS 67211
 (316)260-7491</p> |
| <p>Westar Energy
 (Transmission)
 Greg Roy
 P.O. Box 208
 Wichita, KS 67214
 Office (785) 575-8167
 Cell (785) 554-5489</p> | <p>Wichita Water Department
 Greg Lalley
 8th Floor - City Hall
 455 N. Main Wichita, KS 67202
 (316) 268-4555</p> |
| <p>Westar Energy
 (Distribution)
 Shane Price
 P.O. Box 208
 Wichita, KS 67214
 (316) 261-6315</p> | <p>Wichita Sewer Department
 LaDonna Lawrenz
 8th Floor - City Hall
 455 N. Main Wichita, KS 67202
 (316)268-4501</p> |
| <p>Kansas Gas Service
 Joe Bridgewater
 1021 E. 26th Street N.
 Wichita, KS 67219
 (316) 832-3158</p> | <p>Zayo Fiber
 Jeff Capps
 (316) 847-7970</p> |
| | <p>Black Hills Energy
 Suzette Wilson
 (316)941-1631</p> |
| | <p>Phillips 66
 Kevin Kent
 (316)618-2415</p> |

REDBUD BIKE PATH
 K-96 TO 159TH STREET EAST
 CONTOUR MAP
 CITY OF WICHITA, KANSAS
 GARY JANZEN, P.E. - CITY ENGINEER
 C.O.W. Project #172-65360, C.C.A. #107125

POE & ASSOCIATES, INC.
 CONSULTING ENGINEERS
 544 West Douglas Avenue
 Wichita, KS 67203
 Phone 316/685-4114 FAX 316/685-4444

Engineer: M. LETTNER
 Designer: J. UNRUH
 Dwg: P:\02127 Redbud Wichita\DWG\02127-BAS-tal grade.dwg
 Plot Job No: 102127
 Date: APRIL 2018

Approved: _____
 By: _____
 Date: _____
 No. _____

Sheet of 222