

STATE	PROJECT NO.	YEAR	SHEET NO.	TOTAL SHEETS
KANSAS	87 N-0662-01	2019	52	194

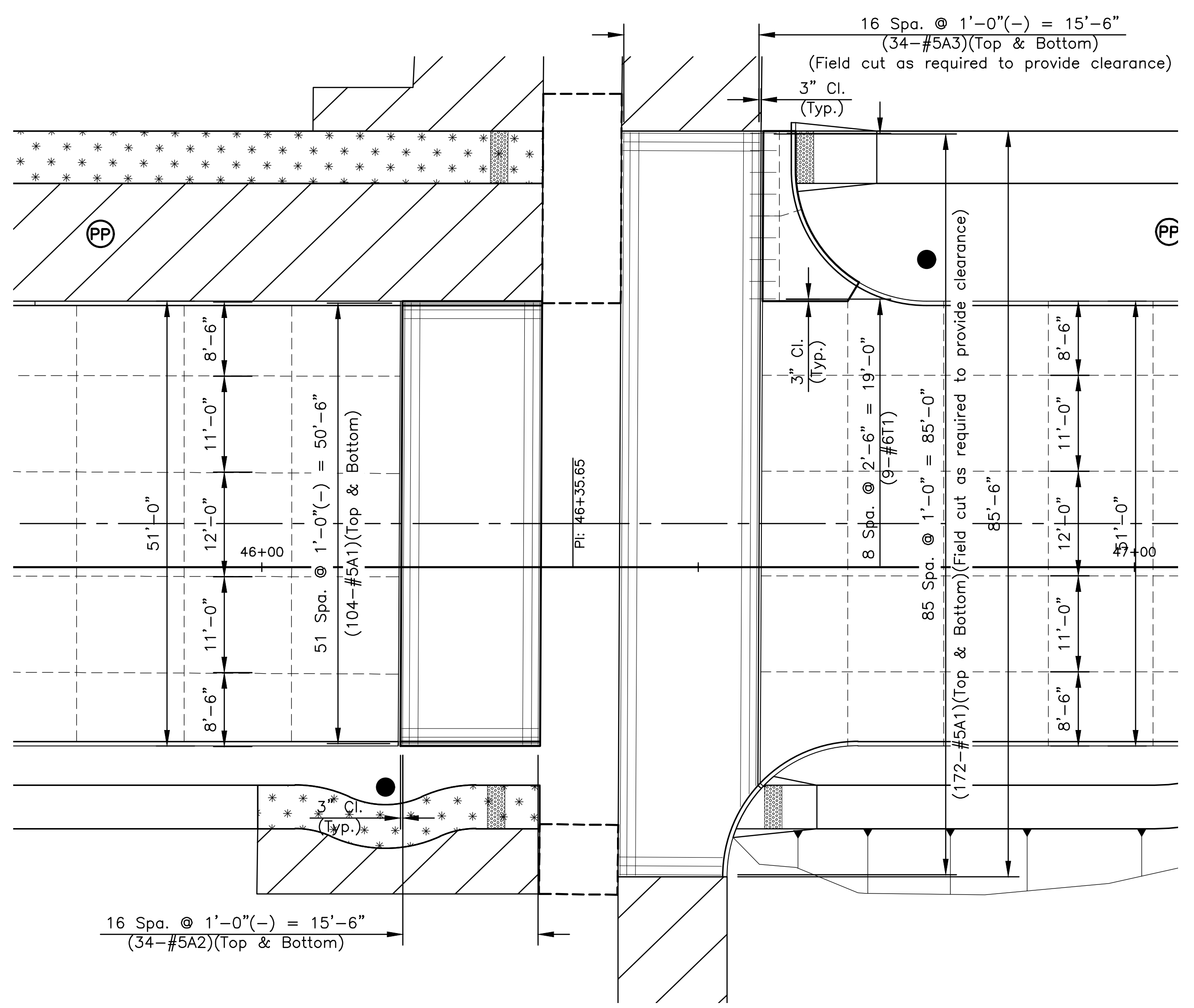

STREET IMPROVEMENTS FOR
17TH ST - BROADWAY TO I-135
FROM BROADWAY TO I-135



RAILROAD APPROACH SLAB PLAN (WASHINGTON)

GENERAL NOTES:

1. Surface of new pavement and crossing material shall be set to identical elevations at their joint of juncture only when the railroad company uses approved mechanical equipment to compact railroad fill and ballast such to preclude track settlement.
2. Railroad track and crossing material elevations or pavement elevations shall be adjusted in a range of one-fourth (1/4) inch to one (1) to allow for track settlement when the railroad company uses hand methods for compaction of railroad fill and ballast or use of other compaction methods which may not preclude track settlement.
3. The exact elevation differential between crossing material and pavement shall be determined by the railroad based on their experience for track settlement with concurrence by the engineer.
4. The unit price bid for "Concrete Approach 12", Railroad, measured on a Sq. Yd. basis, shall be full compensation for furnishing all reinforcing steel; for all concrete; for all excavation; and for all labor, tools, equipment, and incidentals necessary to complete the approach, including the header.
5. Tooled joints shall be edged with 1/4" radius tool for length of joint.
6. Clearance from the face of concrete for all reinforcing steel, unless otherwise noted, shall be 2".
7. All casting to existing concrete, if cast previously, shall be brush blasted and power washed prior to casting concrete.
8. All reinforcing steel shall be epoxy coated. All epoxy coating damaged or removed through cutting shall be replaced as required by Specifications.
9. All work and materials required for installation of expansion joints shall be subsidiary to the bid item "Concrete Approach 12", Railroad".
10. Skew Angle to match existing Railroad Crossing.
11. Median not shown for clarity. See Sheet 69 for Median Details.

RAILROAD GENERAL NOTES:

1. The proposed street improvement project shall not increase the quantity and/or characteristics of the flow in the Railroad's ditches and/or drainage structures.
2. The elevation of the existing top-of-rail profile shall be verified before beginning construction. All discrepancies shall be brought to the attention of the Engineer prior to construction.
3. All demolitions within the Railroad's right-of-way and/or demolition that may impact the Railroad's tracks or operations shall be in compliance with the Railroad's Demolition Guidelines.
4. All construction phasing that may impact the Railroad operations shall be designed to cause no interruption to the Railroad's operation, enabling the track(s) to remain open to traffic per Railroad's requirements.
5. For Railroad coordination please refer to the Railroad Coordination Requirements as part of the project's special provisions.

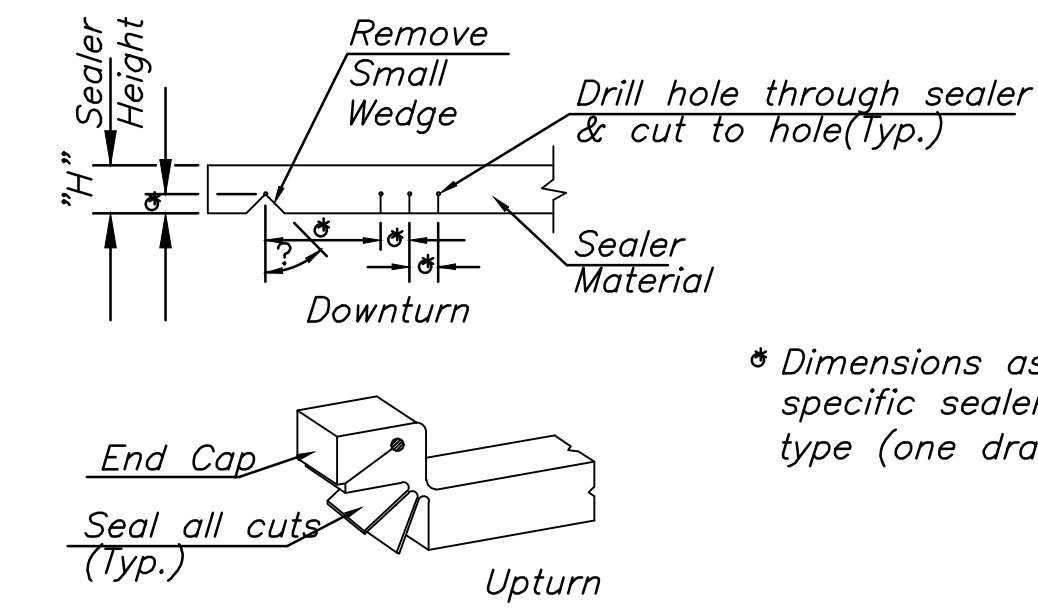

* Dimensions as part of shop drawing for specific sealer material and project curb type (one drawing for each curb type).

EXAMPLE CUTTING AND BENDING DETAILS

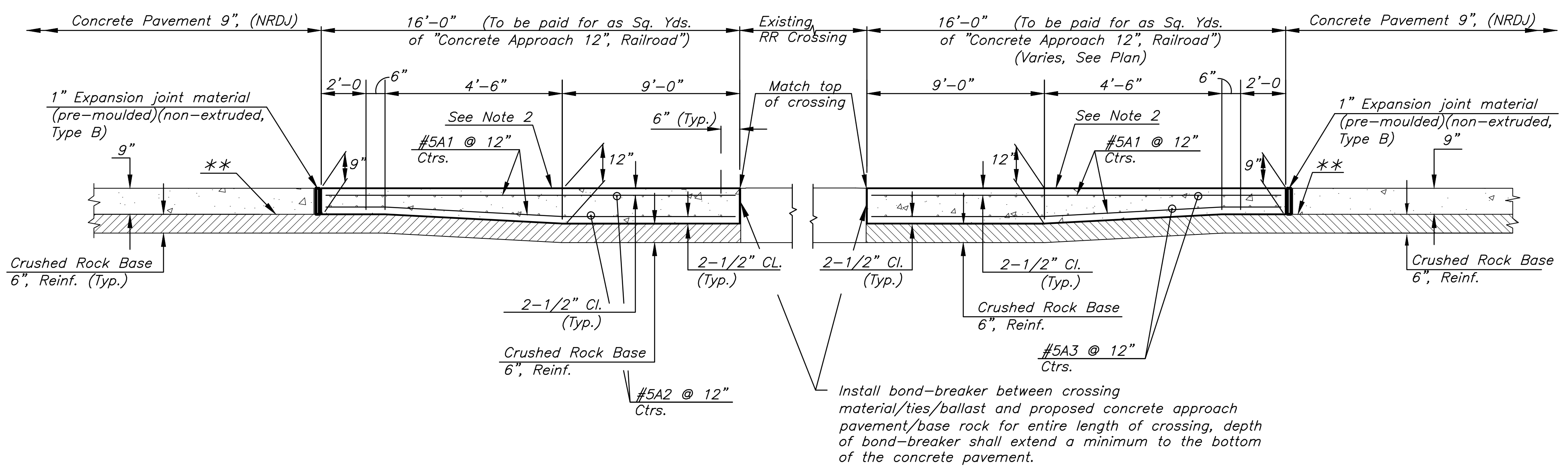

SECTION AT 17TH ST.

** Heavy Coating Bituminous Bond Breaker or smooth steel trowel and coat with curing compound.

FOR INFORMATION ONLY

SUMMARY OF QUANTITIES	
Reinforcing Steel (Gr. 60)	9,380 Lbs.
Concrete (Gr. 4.0)	74.2 Cu. Yds.

FOR INFORMATION ONLY

BILL OF REINFORCING STEEL (BOTH APPROACH SLABS)				
Bar Schedule ≠ ≠				
Bar	A1	A2	A3	T1
No.	276	34	34	9
Size	#5	#5	#5	#6
Length	15'-6"	50'-6"	87'-0"	3'-0"

* Note: Alternate Lap Locations for A3 Bars
≠ ≠ Where bar lengths vary field cut with oxy-fuel or abrasive saw.

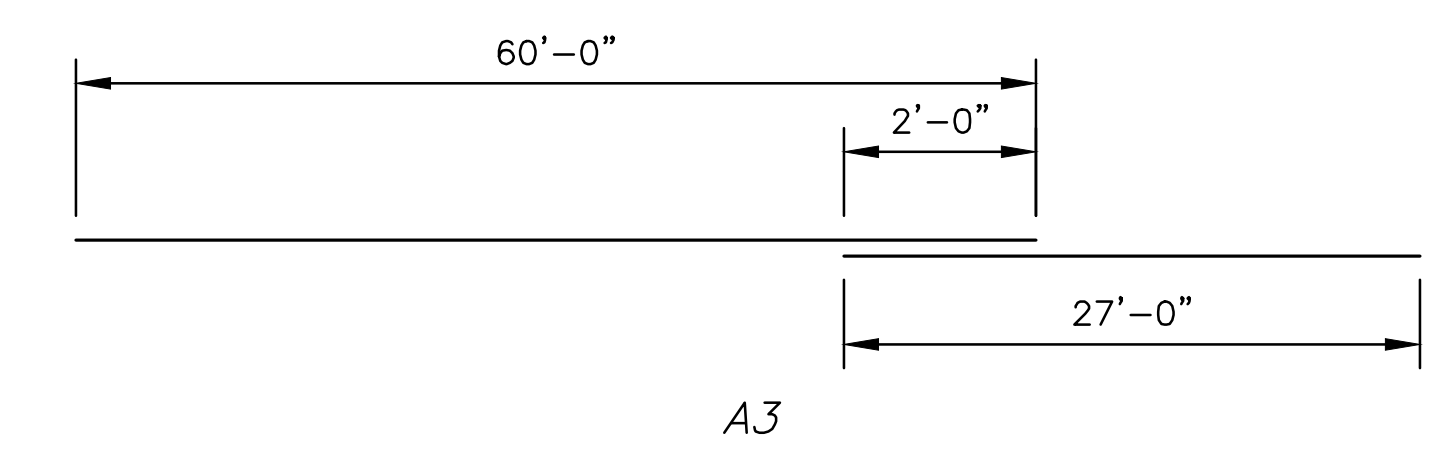

©2019 MKEC Engineering All Rights Reserved www.mkec.com
These drawings and their contents, including, but not limited to, all concepts, designs, & lists are the exclusive property of MKEC Engineering (MKEC), and may not be used or reproduced in any way without the express consent of MKEC.

RAILROAD APPROACH SLAB DETAILS - WASHINGTON

PROJECT NO.	87 N-0662-01	
DATE	8/30/2019	
SCALE	NTS	
DESIGNED	DRAWN	CHECKED
KJS	RAM	KJS
NO.	REVISION	DATE