

SUMMARY OF QUANTITIES (FOR INFORMATION ONLY)		
ITEMS	QUANTITY	UNIT
Pavement Marking (White)(24")	337	L.F.
Pavement Marking (White)(12")	82	L.F.
Pavement Marking (White)(6")	723	L.F.
Pavement Marking (White)(4")	6,239	L.F.
Pavement Marking (Yellow)(12")	28	L.F.
Pavement Marking (Yellow)(4")	10,275	L.F.
Pavement Marking Symbol (Right Turn)	1	Each
Pavement Marking Symbol (Left Turn)	45	Each
Pavement Marking Symbol (Bike)	21	Each
Pavement Marking Symbol (Arrow)	19	Each
Pavement Marking Symbol (Sharrow)	2	Each

RECAPITULATION OF QUANTITIES		
BID ITEM	QUANTITY	UNIT
Pavement Marking	Lump Sum	L.S.

**Pavement Markings** - All pavement markings shall be epoxy, unless otherwise approved by the Engineer. Pavement markings shall be installed per manufacturer's recommendations and shall meet KDOT's 2015 Edition of the Standard Specification Section 806. Full traffic may not be restored (and substantial project completion achieved) until all pavement markings are in place. Should construction timing be such that restoration of traffic becomes necessary during weather prohibiting the installation of markings, the contractor shall install and maintain temporary markings until such time that permanent markings may be properly installed. Except for the material requirement, temporary pavement markings shall be placed equivalent, in every manner (i.e. dimension, frequency, spacing, etc.), to the permanent marking layout. The cost for temporary pavement markings will not be paid for directly, but shall be considered subsidiary to the bid item for "Pavement Markings".

Note: Existing pavement markings removed for temporary traffic control purposes shall be replaced in-kind. Quantities are estimated as follows: 1,300 L.F. of 4" yellow, 770 L.F. of 4" white, and 4 left turn arrows. These quantities for this are reflected in the summary of quantities.

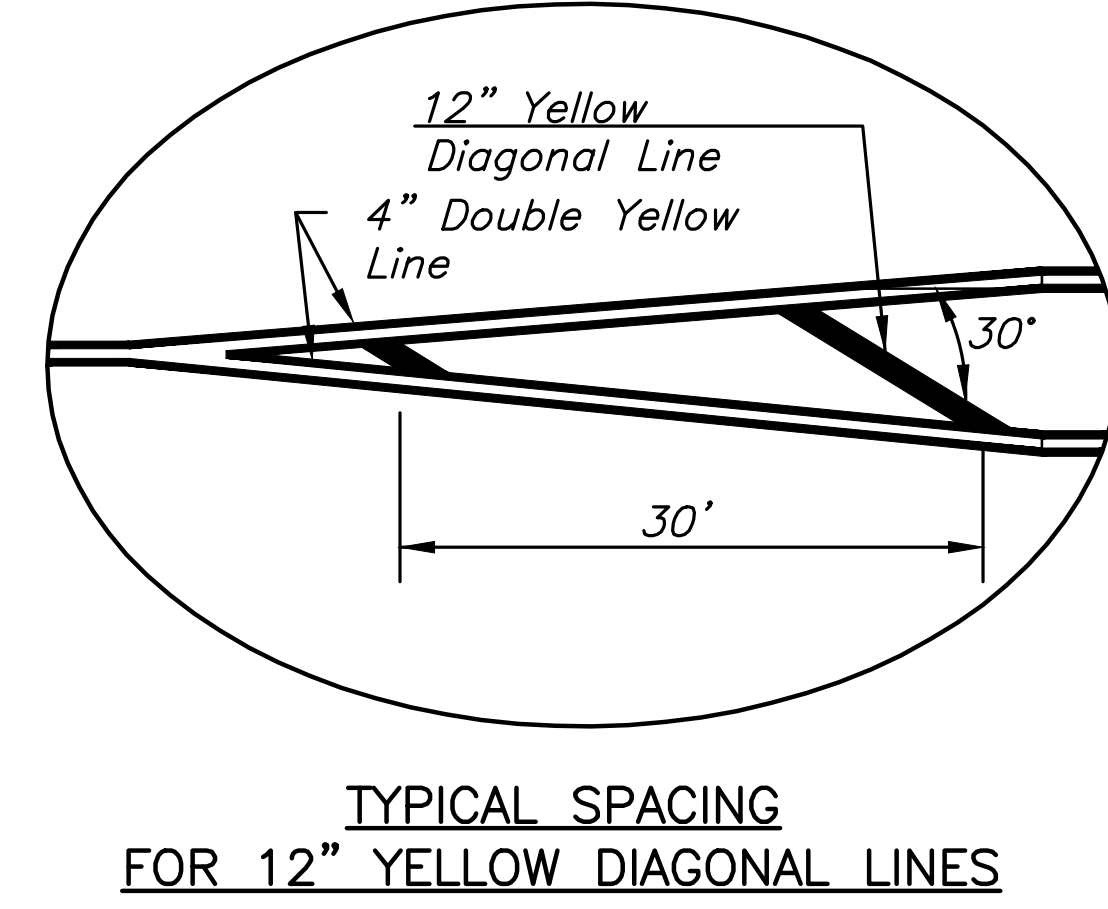
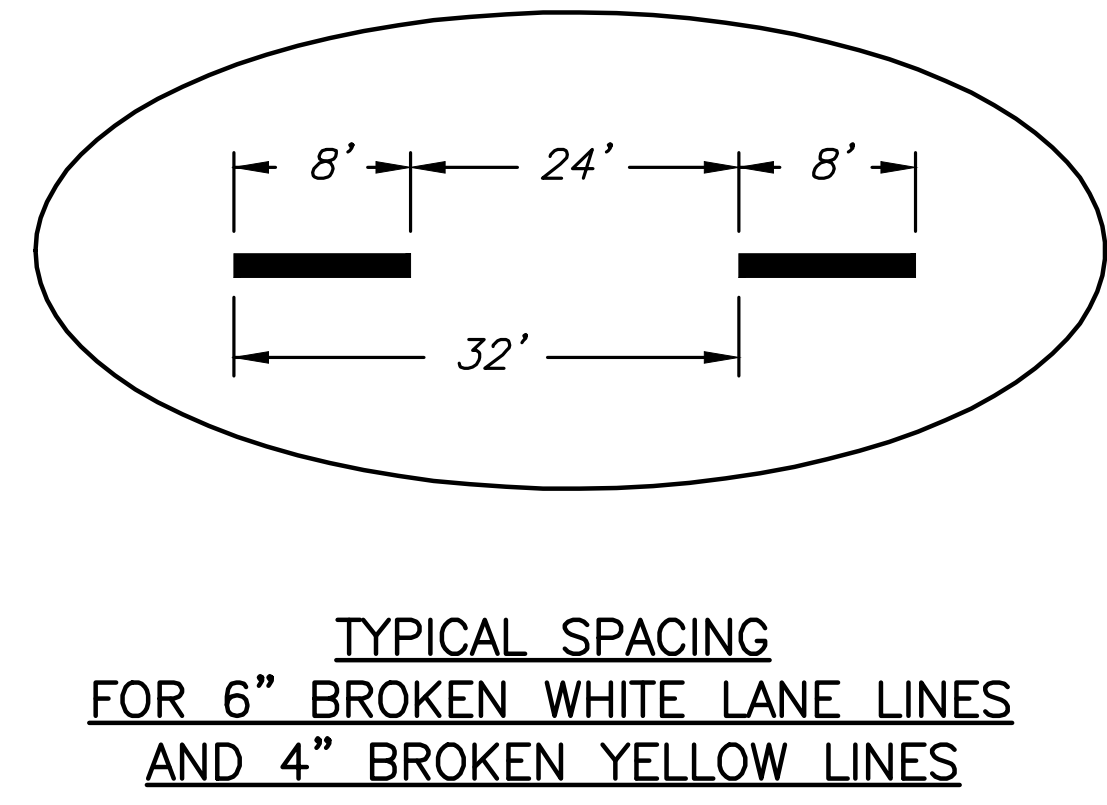
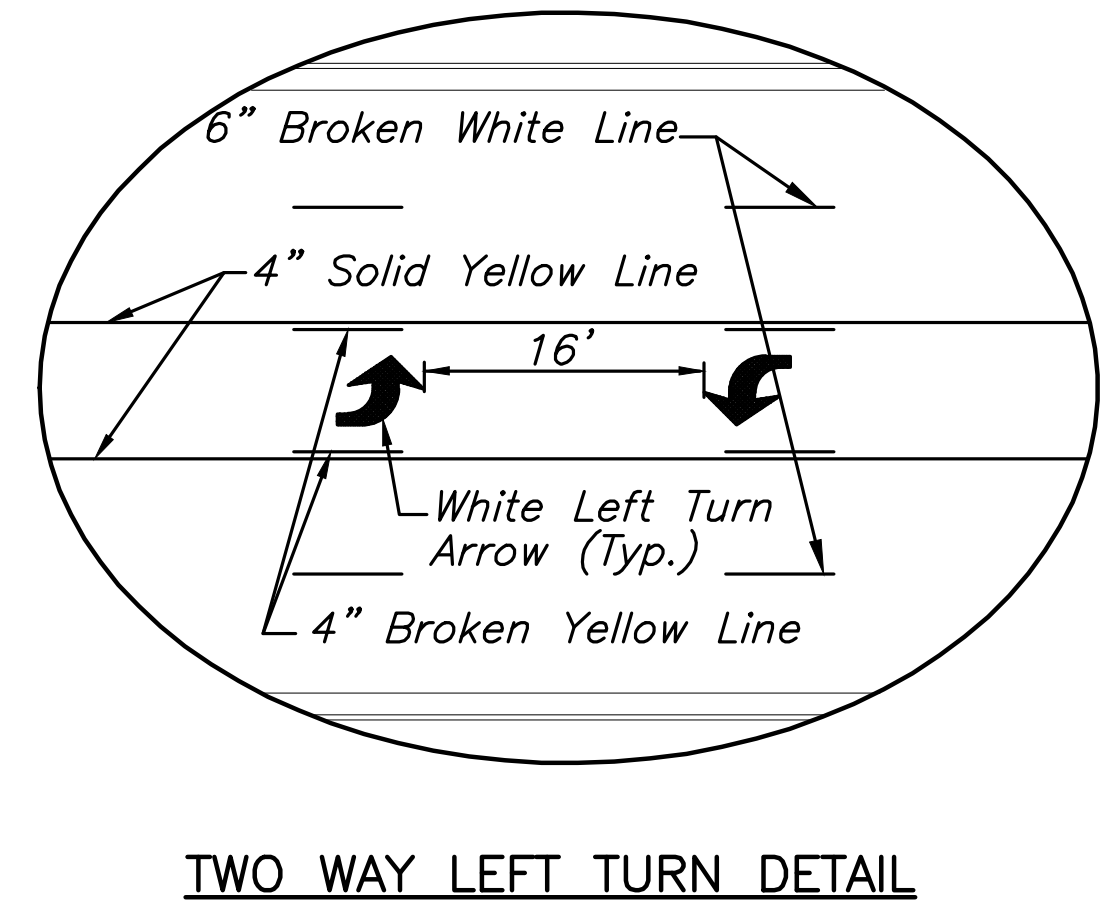
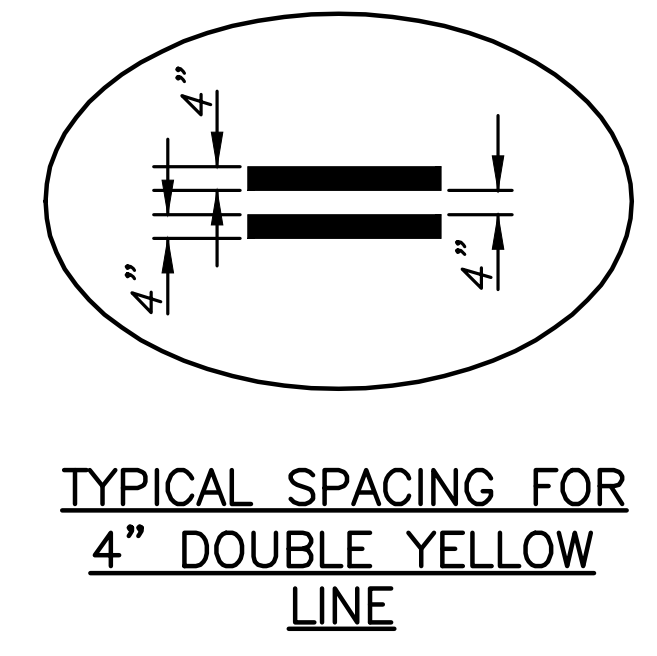
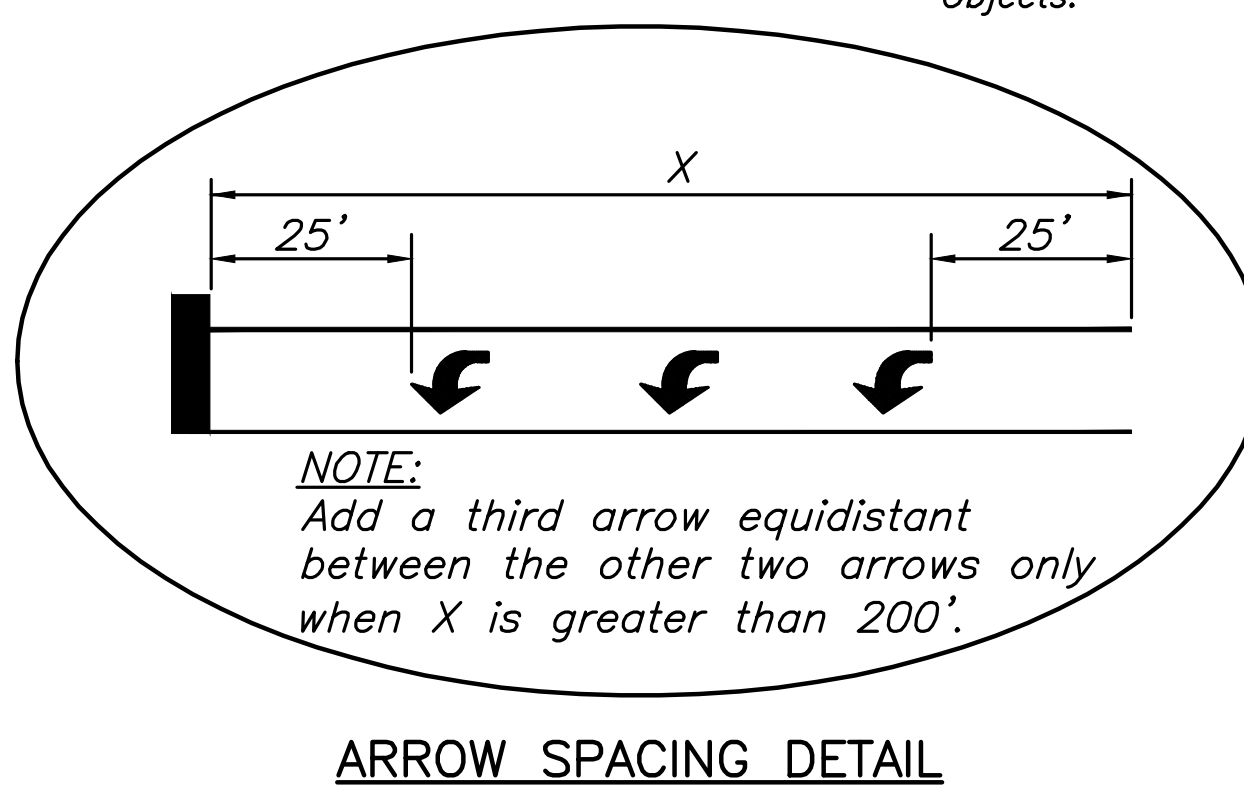
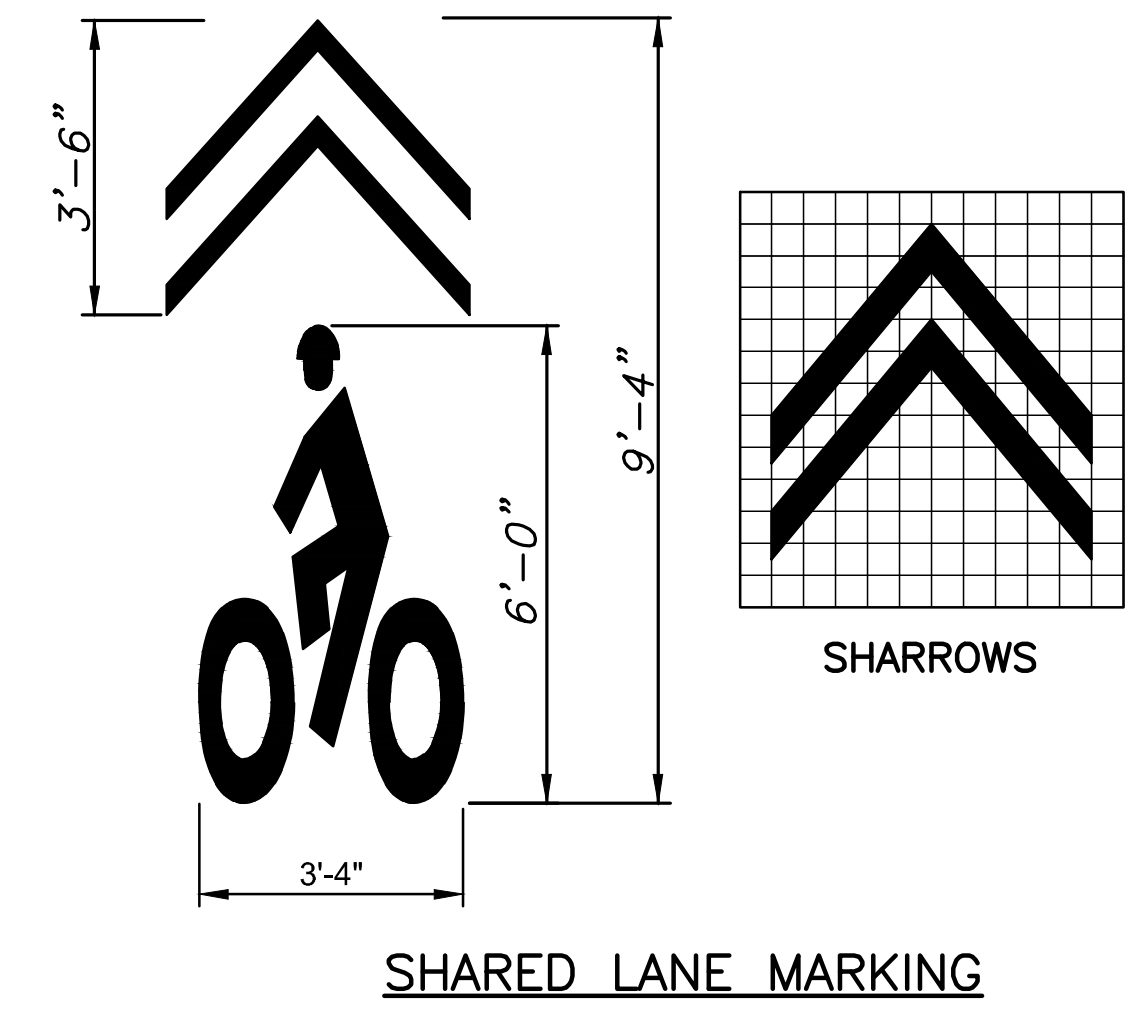
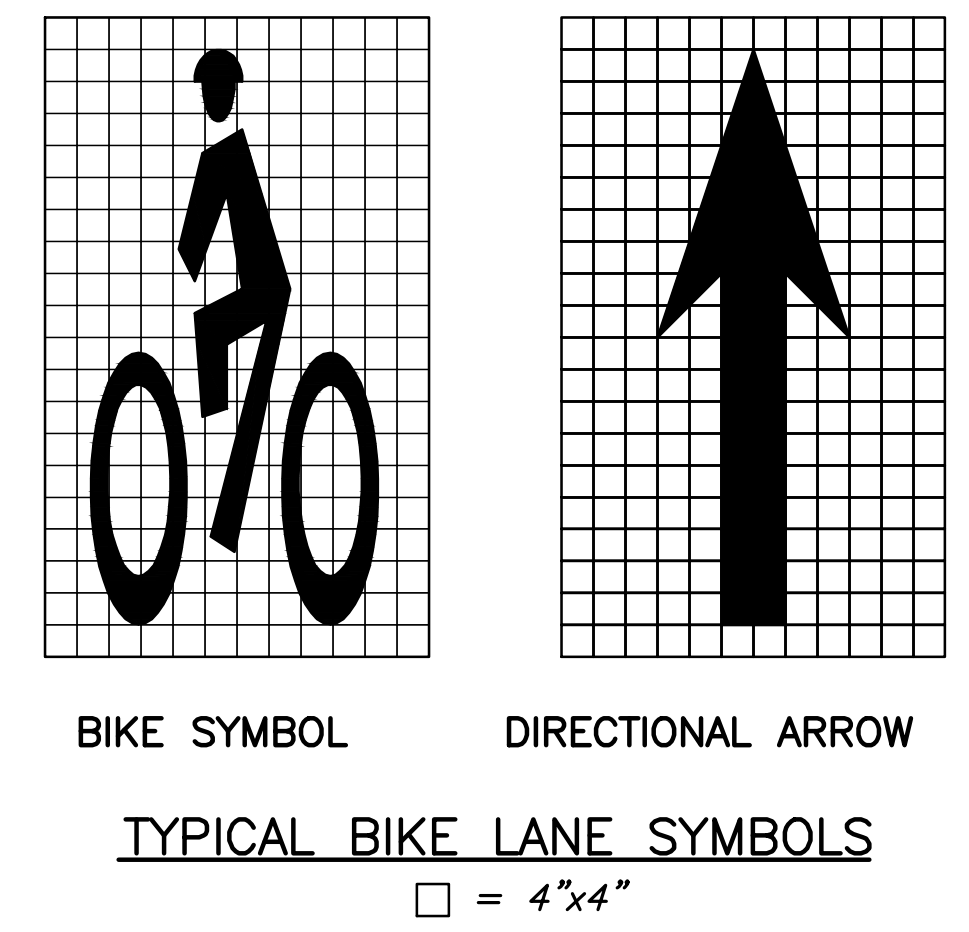
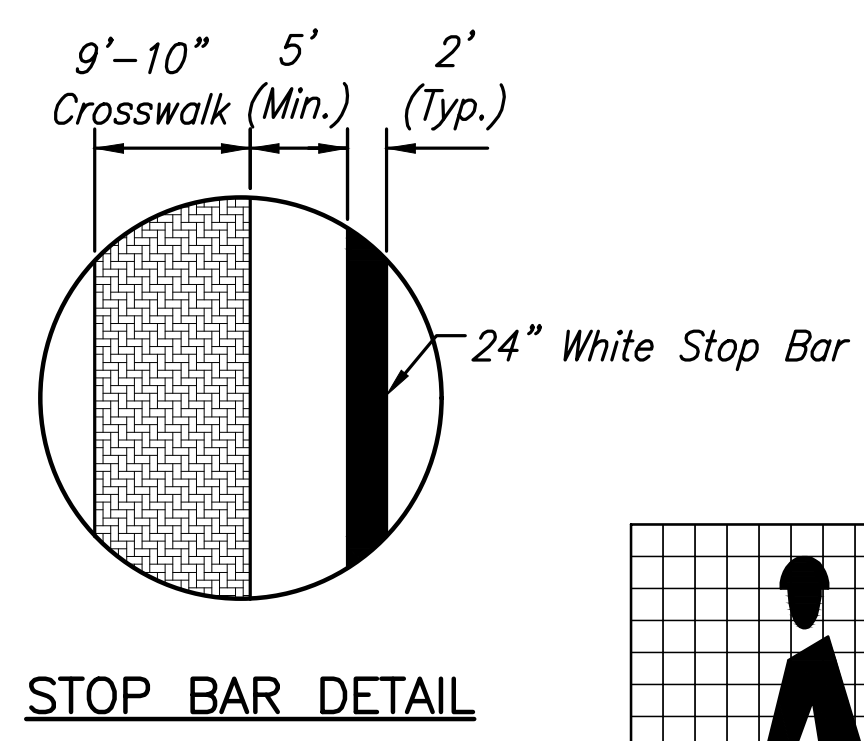
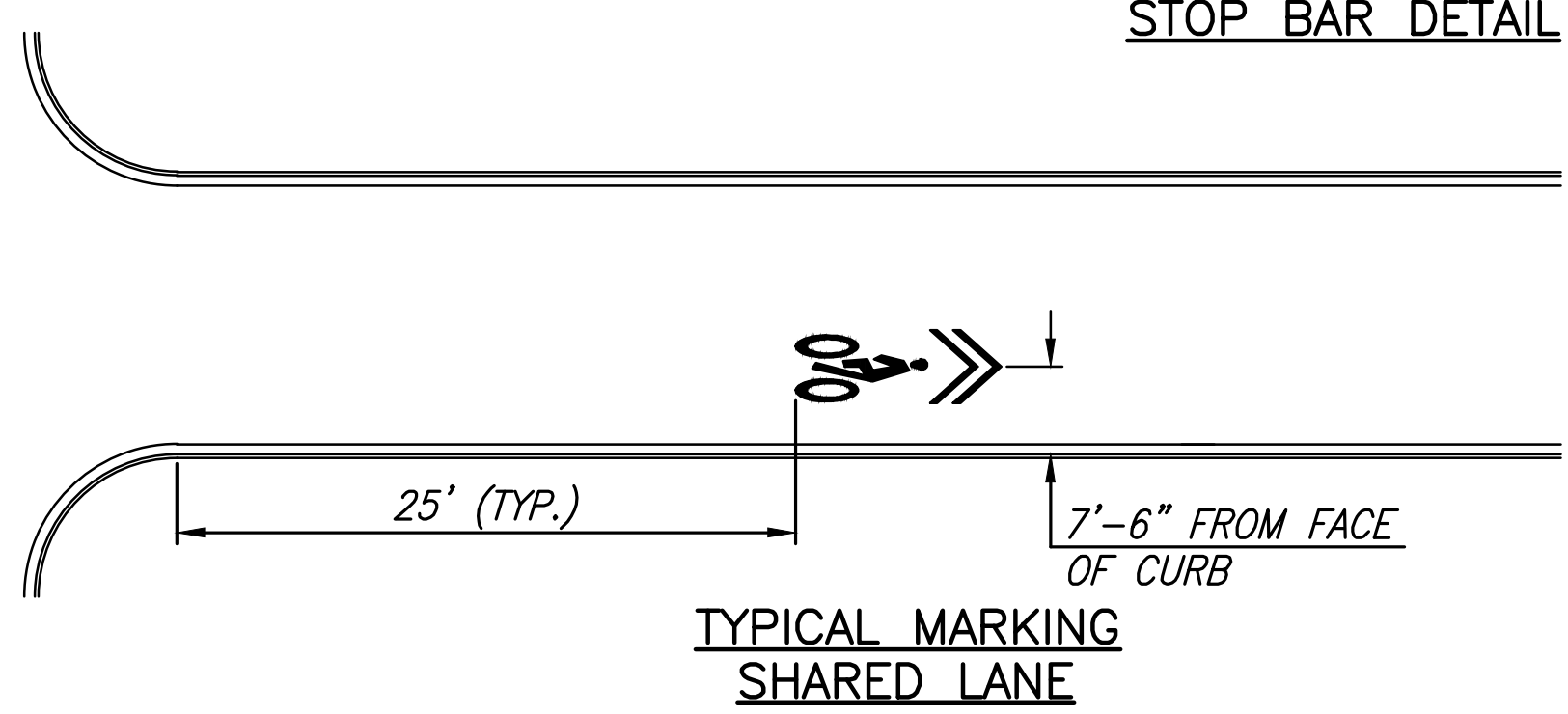
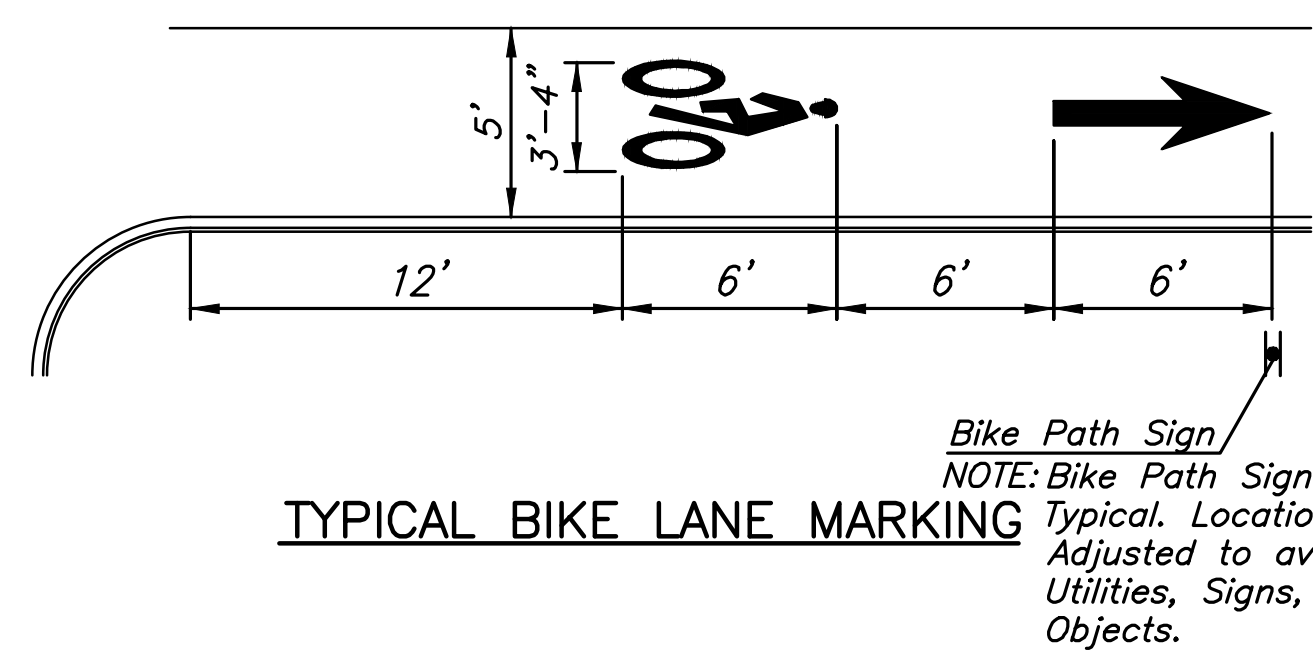
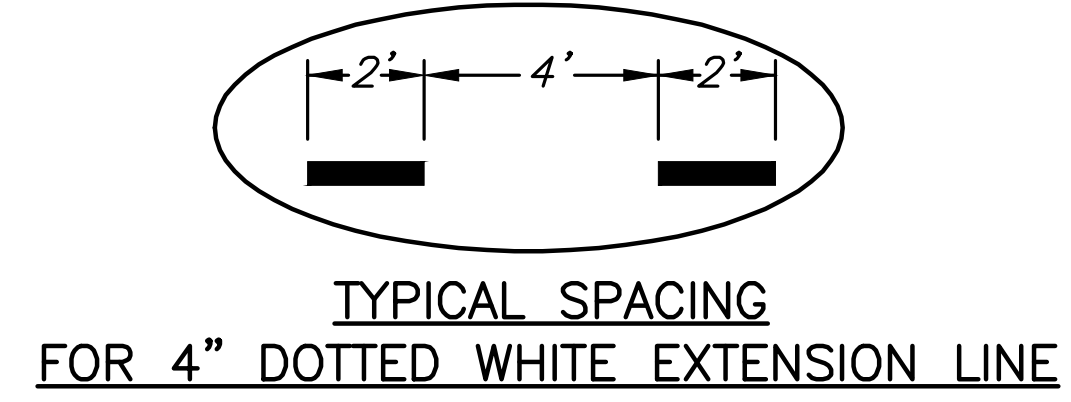
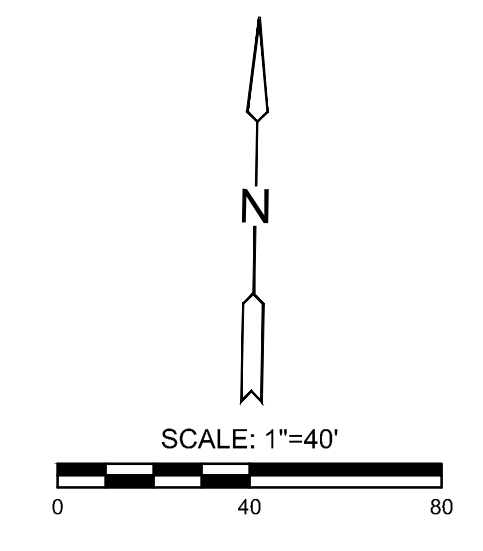
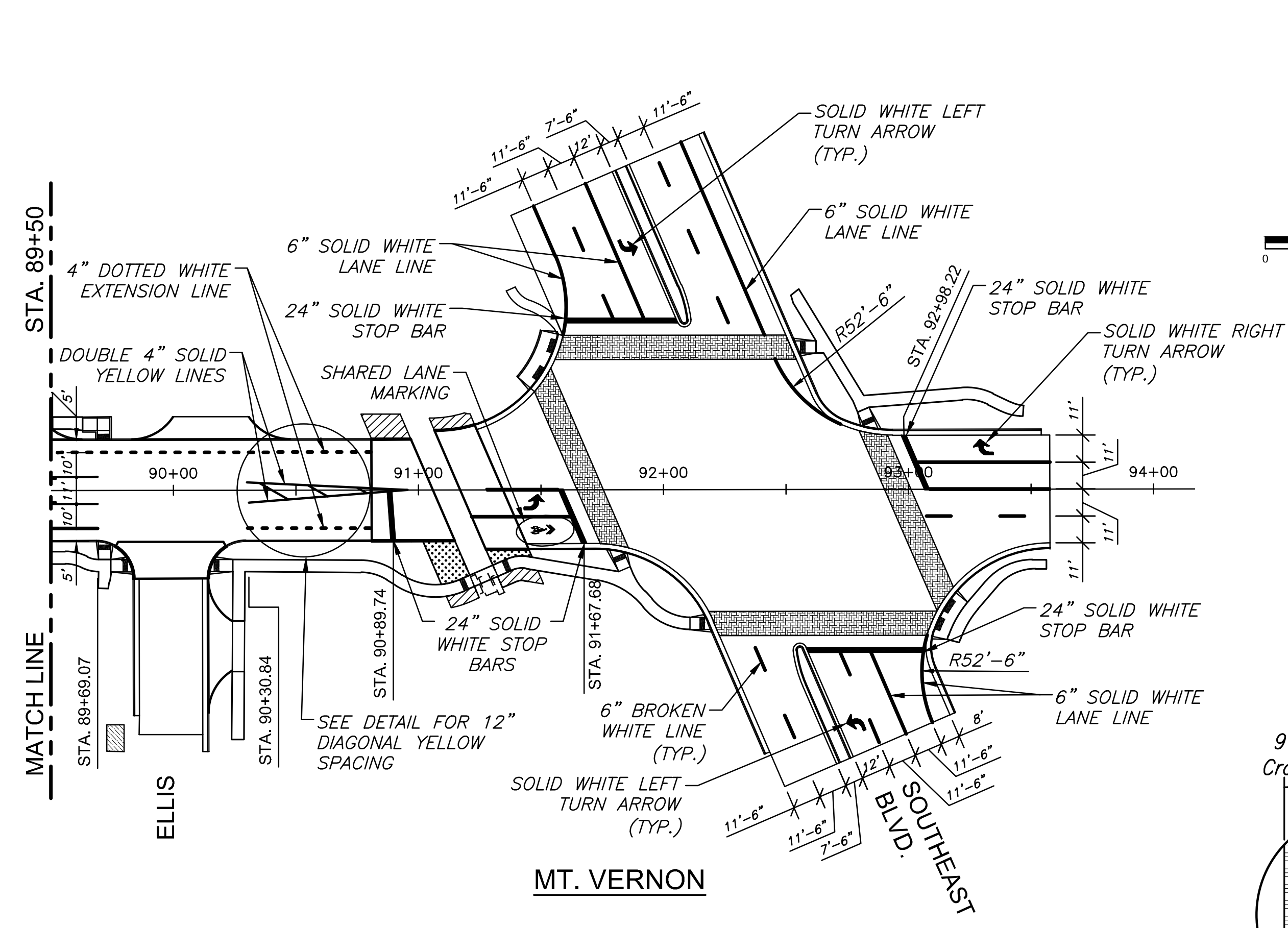

STREET IMPROVEMENTS FOR  
**MT. VERNON IMPROVEMENTS**  
BROADWAY TO SOUTHEAST BLVD.

©2019 MKEC Engineering All Rights Reserved  
www.mkec.com  
These drawings and their contents, including, but not limited to, all concepts, designs, & ideas are the exclusive property of MKEC Engineering (MKEC), and may not be used or reproduced in any way without the express consent of MKEC.

PAVEMENT MARKING PLAN	
PROJECT NO.	87 N-0660-01
DATE	8/19/2019
SCALE	1"=40'
DESIGNED	DRAWN
JRA	RAM
CHECKED	JRA

NO.	REVISION	DATE

J:\CIVIL\0813RD\DWG\MARKING\0813RD-EMD3.DWG