

# GENERAL NOTES:

- THE CONTRACTOR SHALL COMPLY WITH ALL APPLICABLE SAFETY REGULATIONS. ALL CONSTRUCTION SHALL BE COMPLETED FOLLOWING CURRENT CITY STANDARD SPECIFICATIONS AND SPECIAL PROVISIONS.
- CONTRACTOR WILL BE REQUIRED TO PROVIDE NOTICE TO UTILITY COMPANIES A MINIMUM OF SEVENTY-TWO (72) HOURS PRIOR TO ANY EXCAVATION, AS FOLLOWS:

KANSAS ONE-CALL 687-2470

THE CONTRACTOR MUST NOTIFY THE FOLLOWING IN CASE OF AN EMERGENCY:

AT&T	1-800-246-8464
BLACK HILLS ENERGY	1-800-694-8989
CITY OF WICHITA WATER & SEWER	1-316-219-8921
CITY OF WICHITA STORMWATER	1-316-268-4090
CITY OF WICHITA TRAFFIC	1-316-268-4034
COX COMMUNICATIONS	1-888-249-3530
KANSAS GAS SERVICE	1-888-482-4950
WESTAR ENERGY	1-800-544-4857

- UTILITY SERVICE LINES, POLES, ETC. ARE TO BE ADJUSTED AS NECESSARY BY OTHERS PRIOR TO CONSTRUCTION UNLESS THE PLANS SPECIFICALLY CALL FOR THEIR ADJUSTMENT BY THE CONTRACTOR OR UNLESS THE PLANS SPECIFICALLY IDENTIFY A UTILITY TO BE ADJUSTED BY ITS OWNER DURING CONSTRUCTION. EXISTING UTILITIES AND THEIR LOCATION, AS SHOWN ON THE PLANS, REPRESENT THE BEST INFORMATION OBTAINABLE FOR DESIGN. THE CONTRACTOR WILL BE REQUIRED TO WORK AROUND EXISTING UTILITIES WITHIN THE RIGHT-OF-WAY WHICH DO NOT CONFLICT WITH PROPOSED CONSTRUCTION.
- RUBBLE FROM THE REMOVAL OF MISCELLANEOUS STRUCTURES AND EXCESS EXCAVATION WHICH IS TO BE WASTED SHALL BE DISPOSED OF ON SITES TO BE PROVIDED BY THE CONTRACTOR. THESE SITES SHALL BE APPROVED BY THE ENGINEER AS TO SUITABILITY, APPEARANCE AND SITE LOCATION. LOCATIONS, IN THE OPINION OF THE ENGINEER, THAT WILL LEAVE AN UNSIGHTLY APPEARANCE WILL NOT BE APPROVED. ALL DISPOSAL SITES MUST BE APPROVED BY THE KANSAS DEPARTMENT OF HEALTH AND ENVIRONMENT. MATERIAL EITHER STOCKPILED OR DISPOSED OF IN A FLOOD PLAIN WILL REQUIRE A KANSAS STATE BOARD OF AGRICULTURE PERMIT. ANY MATERIAL DUMPED IN WATERS OF THE UNITED STATES OR WETLANDS IS SUBJECT TO U.S. CORPUS OF ENGINEERS PERMITTING REGULATIONS. ANY MATERIAL BURIED OR STOCKPILED BEYOND APPROVED CONSTRUCTION LIMITS WILL REQUIRE ADDITIONAL ARCHAEOLOGICAL INVESTIGATIONS UNLESS BURIED IN A PREVIOUSLY APPROVED BORROW LOCATION.
- TREES AND SHRUBS IN PUBLIC RIGHT-OF-WAY WHICH ARE IN DIRECT CONFLICT WITH PROPOSED NEW CONSTRUCTION SHALL BE REMOVED BY THE CONTRACTOR WITH THE ENGINEER'S APPROVAL. TREES AND SHRUBS WHICH ARE NOT IN DIRECT CONFLICT WITH PROPOSED NEW CONSTRUCTION SHALL BE SAVED AND PROTECTED FROM DAMAGE.
- THE CONTRACTOR SHALL GIVE ALL PROPERTY OWNERS AND/OR TENANTS OF DEVELOPED PROPERTY ADJUTING THE CONSTRUCTION OF THIS PROJECT A MINIMUM OF TEN (10) DAYS NOTICE PRIOR TO START OF CONSTRUCTION.
- THE CONTRACTOR SHALL BE RESPONSIBLE FOR PRESERVING PROPERTY IRONS. THE CONTRACTOR WILL BE REQUIRED TO RE-ESTABLISH ANY PROPERTY IRONS WHICH ARE DAMAGED OR DESTROYED BY HIS CONSTRUCTION OPERATIONS. SUCH IRONS SHALL BE RE-ESTABLISHED BY A LICENSED LAND SURVEYOR IN ACCORDANCE WITH STATE LAWS.
- THE ENGINEERING DIVISION SHALL FIELD LOCATE WATER VALVES ONE TIME DURING CONSTRUCTION WHEN REQUESTED BY THE CONTRACTOR. IT SHALL BE THE CONTRACTOR'S RESPONSIBILITY TO PRESERVE SUCH FIELD LOCATIONS DURING THE CONSTRUCTION PROCESS. WATER VALVES, VALVE BOXES OR FIRE HYDRANTS DAMAGED DURING CONSTRUCTION SHALL BE REPAIRED BY CONTRACTOR AT HIS OWN EXPENSE. VALVE BOXES AND WATER METERS WITHIN THE PROJECT LIMITS SHALL BE ADJUSTED TO MATCH FINAL GRADES BY THE CONTRACTOR.
- THE CONTRACTOR SHALL NOTIFY THE CONSULTANT ENGINEER AND TOM MASON WITH THE CITY AT 316-268-4574 WITH THE ANTICIPATED CONSTRUCTION START DATE AND NOTIFY THEM OF PROJECT COMPLETION. STAKING AND INSPECTION FOR THIS PROJECT WILL BE THE RESPONSIBILITY OF THE CONTRACTOR.
- IF TRAFFIC WILL BE IMPACTED BY CONSTRUCTION, A TRAFFIC CONTROL PLAN MUST BE SUBMITTED AND APPROVED BY THE CITY TRAFFIC ENGINEER, BRIAN COON AT [TRAFFIC@WICHITA.GOV](mailto:TRAFFIC@WICHITA.GOV) BEFORE CONSTRUCTION CAN BEGIN. THE CONTRACTOR SHALL BE RESPONSIBLE FOR ALL TRAFFIC CONTROL MEASURES TO FACILITATE CONSTRUCTION. ALL CONSTRUCTION ZONE MARKINGS AND SIGNAGE SHALL CONFORM TO THE LATEST VERSION OF THE MANUAL ON UNIFORM TRAFFIC CONTROL DEVICES (MUTCD) AS PUBLISHED BY THE US DEPT. OF TRANSPORTATION, FEDERAL HIGHWAY ADMINISTRATION. ALL COSTS ASSOCIATED WITH CONSTRUCTION MARKINGS AND SIGNAGE SHALL BE THE CONTRACTORS RESPONSIBILITY.
- ALL ELEVATIONS SHOWN ARE NAVD 88.
- ALL AREAS DISTURBED DURING CONSTRUCTION THAT WILL NOT BE UNDER PROPOSED PAVEMENT SHALL BE RESTORED TO MATCH EXISTING CONDITIONS.
- ANY SIDEWALK, DRIVE APPROACH, CURB, OR STREET PAVEMENT REMOVED TO CONSTRUCT PROJECT MUST HAVE A PAVEMENT CUT PERMIT AND BE REPLACED BY THE CITY CONTRACTOR. PERMITS CAN BE OBTAINED BY CALLING 316-268-4501 OR 316-268-4480.
- ALL APPLICABLE FEES (TAP, EQUITY, IN LIEU OF & MAIN BENEFIT) MUST BE PAID BEFORE ANY WORK ON THIS PROJECT CAN COMMENCE.
- CITY MAINTENANCE OF WATER MAINS ENDS AT RIGHT-OF-WAY OR EASEMENT LINE OR WITHIN TWO FEET OF VAULT.
- OPENING AND CLOSING OF WATER VALVES SHALL BE DONE SLOWLY TO PREVENT DAMAGE TO THE WATER DISTRIBUTION SYSTEM FROM WATER HAMMER. ALL VALVES CLOSED BY THE CONTRACTOR MUST BE REOPENED AS NEW CONSTRUCTION PERMITS. THE PROJECT INSPECTOR MUST ASCERTAIN THAT ANY VALVE CLOSED BY THE CONTRACTOR IS REOPENED. THE CONTRACTOR WILL BE PERMITTED TO OPERATE WATER VALVES ONLY WHEN THE PROJECT INSPECTOR ASSIGNED TO THE PROJECT IS PRESENT.
- THE CONTRACTOR SHALL LAY A TRACER WIRE AND SET TEST STATIONS ALONG ALL WATER PIPE INSTALLED IN ACCORDANCE WITH CITY SPECIFICATIONS AND TRACER WIRE DETAIL ON DETAIL SHEET WL-101, COST IS SUBSIDIARY TO PIPE INSTALLATION.
- THE CONTRACTOR SHALL PROVIDE MATERIALS FOR TEMPORARY BLOWOFF OF WATERLINES. CONNECTIONS TO THE EXISTING WATERLINE(S) SHALL BE MADE WITH CLEAN, SWABBED PIPE AND FLUSHED UPON COMPLETION OF TIE-INS.
- REQUESTS FOR SHORT TERM WATER INTERRUPTIONS SHALL BE MADE TO THE CITY WATER DISTRIBUTION DIVISION AND WILL BE SUBJECT TO THEIR APPROVAL. THE CONTRACTOR SHALL GIVE WRITTEN NOTICE TO ANY PROPERTY OWNER, BUSINESS, AND/OR TENANTS THAT WILL HAVE WATER SERVICE INTERRUPTED AT LEAST 5 DAYS IN ADVANCE. SUCH NOTIFICATIONS SHOULD INDICATE THE TIME AND DATE THAT THE WATER WILL BE TURNED OFF AND WHEN THE SERVICE WILL BE RESTORED. NO BUSINESS, PROPERTY OWNER, AND/OR TENANTS SHALL BE WITHOUT WATER SERVICE FOR MORE THAN 8 HOURS. PROPOSED TIE IN LOCATIONS WHICH WILL AFFECT WATER SERVICE TO PROPERTY OWNERS SHALL BE PERFORMED DURING NON-PEAK HOURS.
- THE CONTRACTOR MUST SCHEDULE THE CONNECTIONS TO THE EXISTING MAIN WITH THE CITY SUCH THAT THERE IS A MINIMUM DISRUPTION OF SERVICE. CONNECTIONS SHALL BE MADE DURING PERIODS OF LOW WATER USAGE. THE CONTRACTOR SHALL SUBMIT HIS PROPOSED SCHEDULE FOR COMPLETING WORK FOR CITY APPROVAL AT LEAST 10 DAYS PRIOR TO BEGINNING CONSTRUCTION.
- DEFLECTIONS AT PIPE JOINT OR COUPLINGS SHALL NOT EXCEED THE PIPE MANUFACTURERS RECOMMENDED MAXIMUM. WHERE DEFLECTIONS ARE GREATER THAN THE MAXIMUM ALLOWED, THE CONTRACTOR SHALL UTILIZE FITTINGS.
- ANY EXISTING JOINT EXPOSED DURING EXCAVATION SHALL BE REPLACED IF WITHIN FOUR FEET OF PROPOSED JOINT.
- VALVES 12 INCH AND LARGER ARE TO BE OPERATED BY THE CITY WATER DISTRIBUTION DIVISION. 48 HOURS OF ADVANCE NOTICE IS REQUIRED WITH THE WATER DISPATCH AT 316-291-8921.
- ALL WET TAPS SHALL BE INSTALLED BY THE CITY OF WICHITA. THE CONTRACTOR WILL REIMBURSE THE CITY FOR TAPPING FEES PRIOR TO TAP BEING MADE. UNLESS NOTED ON PLANS.
- THE CONTRACTOR SHALL PROTECT FROM DAMAGE AND SUPPORT EXISTING UTILITIES THROUGH CONSTRUCTIONS AS APPROVED BY THE UTILITY OWNER AND THE ENGINEER AT THE CONTRACTORS EXPENSE.
- CONTRACTOR SHALL LIMIT THE EXTENT OF TRENCH OPENINGS OVERNIGHT AND WEEKENDS TO LESS THAN 50 FEET.
- WICHITA FIRE DEPARTMENT INSPECTIONS MAY BE SCHEDULED BY CALLING 316-268-4441.
- ANY SIDEWALK, DRIVE APPROACH, CURB, OR STREET PAVEMENT REMOVED TO CONSTRUCT PROJECT MUST HAVE A PAVEMENT CUT PERMIT AND BE REPLACED BY THE CITY CONTRACTOR. PERMITS CAN BE OBTAINED BY CALLING 316-268-4501 OR 316-268-4480.
- SITE RESTORATION AND PREPARATION SHALL BE SUBSIDIARY TO THE PROJECT.
- THE CONTRACTOR SHALL USE BEST MANAGEMENT PRACTICES (BMP'S) TO PREVENT ERODED SOIL FROM ENTERING DITCHES, CULVERTS, AND DRAINAGE AREAS. STANDARD DETAILS FOR EROSION BMP'S ARE AVAILABLE FROM THE ENGINEER. THE CONTRACTOR SHALL FOLLOW THE INTENT OF THE BMP'S WHICH ACT AS A GUIDELINE.
- EACH BIDDER SHALL VISIT THE SITE OF THE PROJECT THROUGHOUT ITS ENTIRE EXTENT BEFORE SUBMITTING A PROPOSAL IN ORDER TO BECOME BETTER INFORMED OF THE EXISTING FIELD CONDITIONS AND OBSTACLES WHICH MIGHT BE ENCOUNTERED DURING CONSTRUCTION. EACH BIDDER SHOULD UNDERSTAND THAT NO ADDITIONAL COMPENSATION WILL BE AWARDED FOR EXTRA WORK THAT SHOULD HAVE BEEN EVALUATED PRIOR TO BIDDING.
- ALL WATER PIPE TRENCHING IN PAVEMENT OR DRIVEWAYS, WHICH WILL BE REQUIRED TO CARRY TRAFFIC UNTIL PERMANENT PAVING REPLACEMENT, SHALL BE TOPPED WITH A MINIMUM OF 6" CRUSHED ROCK (COMPACTED) TO BE INCIDENTAL TO THE PROJECT. CONTRACTOR SHALL BE REQUIRED TO MAINTAIN TEMPORARY CRUSHED ROCK UNTIL PERMANENT PAVEMENT IS INSTALLED.
- CONTRACTOR TO FIELD VERIFY LOCATION AND DEPTH OF ALL UTILITIES PRIOR TO CONSTRUCTION AND REPORT FINDINGS TO PROJECT ENGINEER. LOCATION INFORMATION HAS BEEN OBTAINED FROM VARIOUS COMPANIES AND IS EITHER FROM COMPANY UTILITY DRAWINGS OR COMPANY PROVIDED FIELD LOCATIONS. THE PLAN LOCATIONS SHOWN ARE NOT GUARANTEED. ADDITIONAL EXISTING UTILITIES MAY BE ENCOUNTERED.
- KAW VALLEY ENGINEERING CAN PROVIDE INSPECTION AND TESTING SERVICES. CONTACT MICHAEL COLLINS AT 785-223-2664.

# FIRE HYDRANT TO SERVE

## LOT 1, BLOCK A, CLARKDALE 4TH ADD.

### LOTS 11 & 12 CLARKDALE SUB.

## 6220 S SENECA ST

### CITY OF WICHITA, KANSAS

GARY JANZEN, P.E. CITY ENGINEER  
PROJECT NUMBER  
2248 PPW (183021)

Date: 2020-04-09  
Inspector: M. Collins/A. Thompson  
Design/Inspecting Firm: Kaw Valley Engineering, Inc.  
Contractor: Wilks Underground Utilities LLC.  
Subcontractor: Wilks Underground Utilities LLC.  
Built in general conformance to construction plans, except where noted on plans.



### VICINITY MAP

### SHEET INDEX

01	TITLE SHEET
02	FIRE HYDRANT PLAN & PROFILE
03	EROSION CONTROL PLAN
04	STANDARD DETAILS
05-09	EROSION CONTROL DETAILS
10	PLAT

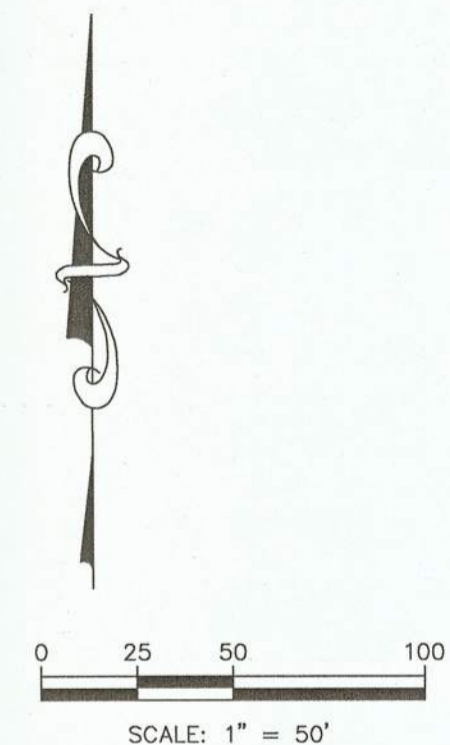
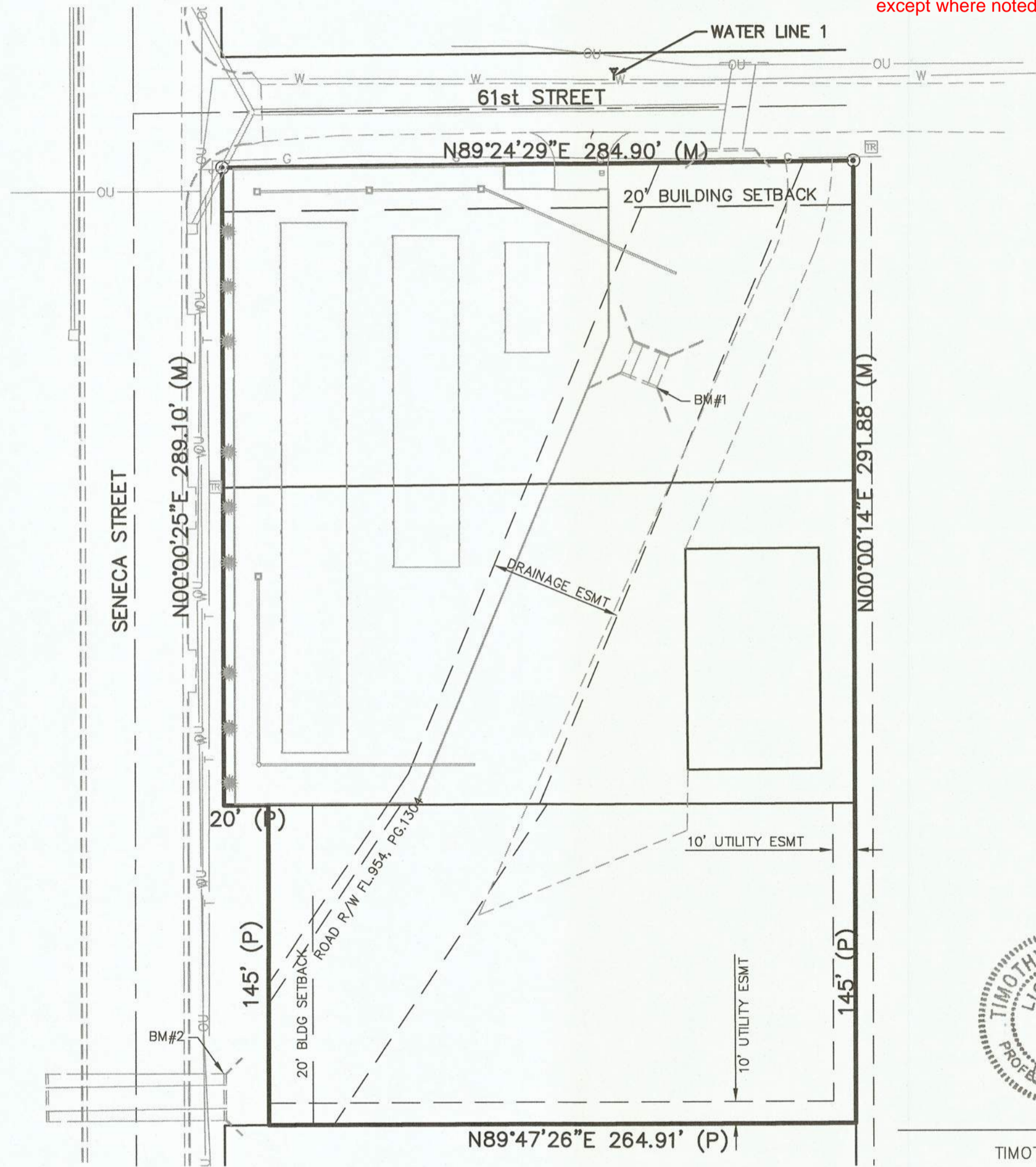

THIS PLAN SHEET IS PART OF AN OVERALL KAW VALLEY ENGINEERING PLAN SET FOR THE SPECIFIC IMPROVEMENTS CONTEMPLATED THEREIN. AS SUCH, THE INFORMATION CONTAINED MAY BE LIMITED AND SHOULD ONLY BE INTERPRETED WITHIN THE CONTEXT OF THE COMPLETE PLAN SET.

**DATUM BENCHMARK:**  
VERTICAL DATUM IS NAVD 88 ESTABLISHED USING OPUS PROJECTS ON PROJECT CONTROL.

BM #1 SQUARE CUT IN SOUTHEAST CORNER OF HEADWALL APPROXIMATELY 89 FEET WEST AND 102 FEET SOUTH OF THE NORTHEAST CORNER OF LOT 11, CLARKDALE SUB.  
ELEV=1266.21 (NAVD 88)

BM #2 SQUARE CUT IN NORTHEAST CORNER OF EAST HEADWALL APPROXIMATELY 19 FEET WEST AND 24 FEET NORTH OF THE NORTHWEST CORNER OF LOT 1, BLOCK A, CLARKDALE 4TH ADD.  
ELEV=1267.05 (NAVD 88)



TIMOTHY R. AUSTIN  
PROFESSIONAL ENGINEER

APPROVED AS NOTED  
BY CITY ENGINEER OF WICHITA  
& BY WICHITA FIRE DEPARTMENT

Engineering With Patchy 6-24-19  
Utilities Dray Kelly 6-25-19  
Fire Dept. J. Miller 6-25-19

NOTE TO CONTRACTORS

**PUBLIC PROPERTY:**  
Inspection and testing for the waterline is to be provided by a Licensed Consulting Engineering Firm under contract with the Owner/Developer. Said inspection to be in accordance with the City of Wichita standard construction engineering practices and certified by a Licensed Professional Engineer licensed in the State of Kansas. No work shall be performed in dedicated easements or public right-of-way by the Contractor without such inspection nor shall any work be commenced without written authorization by City Engineering. All Construction and Materials shall comply with the City of Wichita Specifications and Standards and Special Provision (on file and available in the City Engineer's Office) or on the City's Website.

**PRIVATE PROPERTY:**  
Installation and testing for the fire protection line is to be performed by a City of Wichita licensed fire protection contractor in accordance with the fire codes as adopted by the City of Wichita. All material and construction practices for the fire protection line shall comply with the fire codes as adopted by the City of Wichita (available from the City of Wichita Fire Department). The Contractor shall not commence work without notification and approval of the Wichita Fire Department. Inspection of the fire protection line is to be provided by a licensed Engineering Firm under contract with the Owner/Developer and the Fire Department. The contractor shall not start work until the project inspector is assigned to the project and present on the site. Any work done without inspection will be required to be uncovered for inspection.

An approved copy of these plans signed by City staff are required on-site.

**SAFETY NOTICE TO CONTRACTOR**  
IN ACCORDANCE WITH GENERALLY ACCEPTED CONSTRUCTION PRACTICES, THE CONTRACTOR WILL BE SOLELY AND COMPLETELY RESPONSIBLE FOR CONDITIONS OF THE JOB SITE, INCLUDING SAFETY OF ALL PERSONS AND PROPERTY DURING PERFORMANCE OF THE WORK. THIS REQUIREMENT WILL APPLY CONTINUOUSLY AND NOT BE LIMITED TO NORMAL WORKING HOURS.

**WARRANTY / DISCLAIMER**  
THE DESIGNS REPRESENTED IN THESE PLANS ARE IN ACCORDANCE WITH ESTABLISHED PRACTICES OF CIVIL ENGINEERING FOR THE DESIGN FUNCTIONS AND USES INTENDED BY THE OWNER AT THIS TIME. HOWEVER, NEITHER KAW VALLEY ENGINEERING, INC NOR ITS PERSONNEL CAN OR DO WARRANTY THESE DESIGNS OR PLANS AS CONSTRUCTED, EXCEPT IN THE SPECIFIC CASES WHERE KAW VALLEY ENGINEERING PERSONNEL INSPECT AND CONTROL THE PHYSICAL CONSTRUCTION ON A CONTEMPORARY BASIS AT THE SITE.

**CAUTION - NOTICE TO CONTRACTOR**  
THE CONTRACTOR IS SPECIFICALLY CAUTIONED THAT THE LOCATION AND/OR ELEVATION OF EXISTING UTILITIES AS SHOWN ON THESE PLANS IS BASED ON RECORDS OF THE VARIOUS UTILITY COMPANIES AND, WHERE POSSIBLE, MEASUREMENTS TAKEN IN THE FIELD. THE INFORMATION IS NOT TO BE RELIED ON AS BEING EXACT OR COMPLETE. THE CONTRACTOR MUST CALL THE APPROPRIATE UTILITY COMPANY AT LEAST 72 HOURS BEFORE ANY EXCAVATION TO REQUEST EXACT FIELD LOCATION OF UTILITIES. IT SHALL BE THE RESPONSIBILITY OF THE CONTRACTOR TO RELOCATE ALL EXISTING UTILITIES WHICH CONFLICT WITH PROPOSED IMPROVEMENTS SHOWN ON THE PLANS.  
**THE CONTRACTOR SHALL EXPOSE EXISTING UTILITIES AT LOCATIONS OF POSSIBLE CONFLICTS PRIOR TO ANY CONSTRUCTION.**

**JUNE 2019**

PROJ. NO. G19\_1053  
CFN: 1053WTS

DSN: TRA  
DWN: EAM

TIMOTHY R. AUSTIN  
ENGINEER  
KS # 11496

200 N. EMPORIA, SUITE 100  
WICHITA, KANSAS 67202  
PH. (316) 440-4304 | FAX (316) 440-4309  
wh@kveg.com | www.kveg.com

**KAW VALLEY ENGINEERING**

KAW VALLEY ENGINEERING, INC., IS AUTHORIZED TO OFFER ENGINEERING SERVICES BY KANSAS STATE CERTIFICATE OF AUTHORIZATION # E-113. EXPIRES 12/31/20









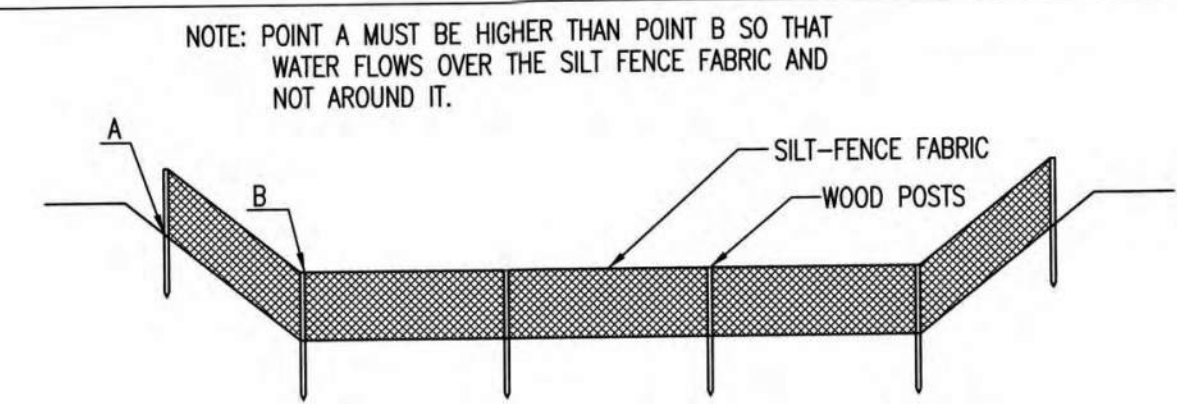

**ELEVATION**  
**SILT FENCE DITCH CHECKS**  
(STREAM PROTECTION)

**MATERIAL SPECIFICATION:**

SILT FENCE FABRIC SHOULD CONFORM TO THE AASHTO M288 96 SILT FENCE SPECIFICATION. THE POSTS USED TO SUPPORT THE SILT FENCE FABRIC SHOULD BE A HARDWOOD MATERIAL WITH THE FOLLOWING MINIMUM DIMENSIONS: 2" SQUARE (NOMINAL) BY 4' LONG. SILT FENCE FABRIC SHOULD BE ATTACHED TO THE WOODEN POSTS WITH STAPLES, WIRE, ZIP TIES, OR NAILS.

**PLACEMENT:**

PLACE SILT FENCE IN DITCHES WHERE IT IS UNLIKELY THAT IT WILL BE OVERTOPPED. WATER SHOULD FLOW THROUGH A SILT FENCE DITCH CHECK, NOT OVER IT. SILT FENCE DITCH CHECKS OFTEN FAIL WHEN OVERTOPPED. SILT FENCE DITCH CHECKS SHOULD BE PLACED PERPENDICULAR TO THE FLOWLINE OF THE DITCH. THE SILT FENCE SHOULD EXTEND FAR ENOUGH SO THAT THE GROUND LEVEL AT THE ENDS OF THE FENCE IS HIGHER THAN THE TOP OF THE LOW POINT OF THE FENCE. THIS PREVENTS WATER FROM FLOWING AROUND THE CHECK. SILT FENCE DITCH CHECKS SHOULD NOT BE PLACED IN DITCHES WHERE HIGH FLOWS ARE EXPECTED. ROCK CHECKS SHOULD BE USED INSTEAD. SILT FENCE SHOULD BE PLACED IN DITCHES WITH SLOPES OF 6% OR LESS. FOR SLOPES STEEPER THAN 6%, ROCK CHECKS SHOULD BE USED.

THE FOLLOWING TABLE PROVIDES CHECK SPACING FOR A GIVEN DITCH GRADE:

DITCH CHECK DITCH GRADE (%)	SPACING CHECK SPACING (FEET)
0.5	200
1.0	200
2.0	100
3.0	65
4.0	50
5.0	40
6.0	30

**PROPER INSTALLATION METHOD:**

EXCAVATE A TRENCH PERPENDICULAR TO THE DITCH FLOWLINE THAT IS AT LEAST 12" DEEP BY 6" WIDE. EXTEND THE TRENCH IN A STRAIGHT LINE ALONG THE ENTIRE LENGTH OF THE PROPOSED DITCH CHECK. PLACE THE SOIL ON THE UPSTREAM SIDE OF THE TRENCH FOR LATER USE. ROLL OUT A CONTINUOUS LENGTH OF SILT FENCE FABRIC ON THE DOWNSTREAM SIDE OF THE TRENCH. PLACE THE EDGE OF THE FABRIC IN THE TRENCH STARTING AT THE TOP UPSTREAM EDGE OF THE TRENCH. LINE TWO SIDES OF THE TRENCH WITH THE FABRIC AS SHOWN ON DETAIL. BACKFILL OVER THE FABRIC IN THE TRENCH WITH THE EXCAVATED SOIL AND COMPACT. AFTER FILLING THE TRENCH, APPROXIMATELY 24" TO 36" OF SILT FENCE FABRIC SHOULD REMAIN EXPOSED. LAY THE EXPOSED SILT FENCE ON THE UPSTREAM SIDE OF THE TRENCH TO CLEAR AN AREA FOR DRIVING IN THE POSTS. JUST DOWNSTREAM OF THE TRENCH, DRIVE POSTS INTO THE GROUND TO A DEPTH OF AT LEAST 24". PLACE POSTS NO MORE THAN 4' APART. ATTACH THE SILT FENCE TO THE ANCHORED POST WITH STAPLES, WIRE, ZIP TIES, OR NAILS.

**LIST OF COMMON PLACEMENT/INSTALLATION MISTAKES TO AVOID:**

WATER SHOULD FLOW THROUGH A SILT FENCE DITCH CHECK—NOT OVER IT. PLACE SILT FENCE IN DITCHES WHERE IT IS UNLIKELY THAT IT WILL BE OVERTOPPED. SILT FENCE INSTALLATIONS QUICKLY DETERIORATE WHEN WATER OVERTOPS THEM. DO NOT PLACE SILT FENCE POSTS ON THE UPSTREAM SIDE OF THE SILT FENCE FABRIC. IN THIS CONFIGURATION, THE FORCE OF THE WATER IS NOT RESTRICTED BY THE POSTS, BUT ONLY BY THE STAPLES (WIRE, ZIP TIES, NAILS, ETC.). THE SILT FENCE WILL RIP AND FAIL. DO NOT PLACE A SILT FENCE DITCH CHECK DIRECTLY IN FRONT OF A CULVERT OUTLET. IT WILL NOT STAND UP TO THE CONCENTRATED FLOW. DO NOT PLACE SILT FENCE DITCH CHECKS IN DITCHES THAT WILL LIKELY EXPERIENCE HIGH FLOWS. THEY WILL NOT STAND UP TO CONCENTRATED FLOW. FOLLOW PRESCRIBED DITCH CHECK SPACING GUIDELINES. IF SPACING GUIDELINES ARE EXCEEDED, EROSION WILL OCCUR BETWEEN THE DITCH CHECKS. DO NOT ALLOW WATER TO FLOW AROUND THE DITCH CHECK. MAKE SURE THAT THE DITCH CHECK IS LONG ENOUGH SO THAT THE GROUND LEVEL AT THE ENDS OF THE FENCE IS HIGHER THAN THE LOW POINT ON THE TOP OF THE FENCE. DO NOT PLACE SILT FENCE DITCH CHECKS IN CHANNELS WITH SHALLOW SOILS UNDERLAIN BY ROCK. IF THE CHECK IS NOT ANCHORED SUFFICIENTLY, IT WILL WASH OUT.

**INSPECTION AND MAINTENANCE:**

SILT FENCE DITCH CHECKS SHOULD BE INSPECTED EVERY 7 DAYS AND WITHIN 24 HOURS OF A RAINFALL OF 1/2" OR MORE. THE FOLLOWING IS A LIST OF QUESTIONS THAT SHOULD BE ADDRESSED DURING EACH INSPECTION:  
 DOES WATER FLOW AROUND THE DITCH CHECK?  
 DOES WATER FLOW UNDER THE DITCH CHECK?  
 DOES THE SILT FENCE SAG EXCESSIVELY?  
 HAS THE SILT FENCE TORN OR BECOME DETACHED FROM THE POSTS?  
 DOES SEDIMENT NEED TO BE REMOVED FROM BEHIND THE DITCH CHECK?

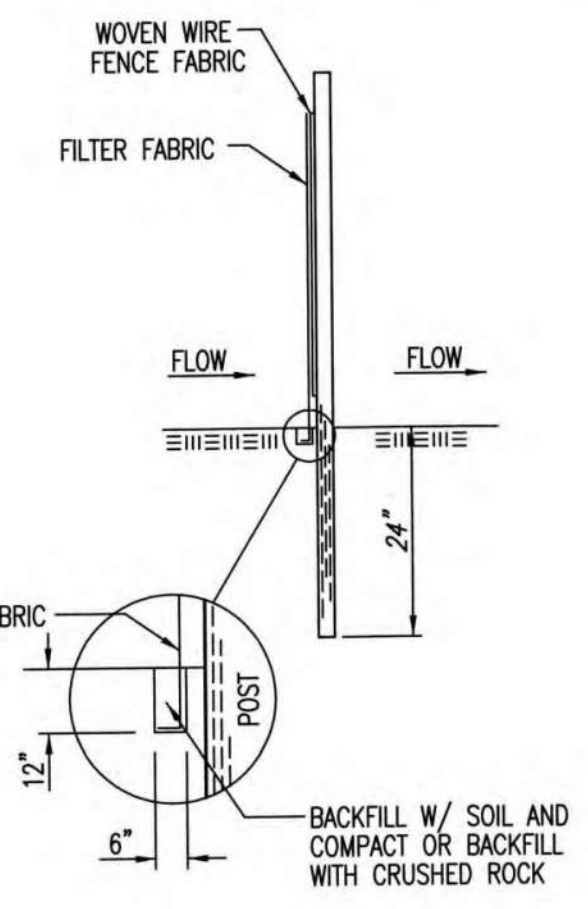

**ANCHOR TRENCH DETAIL**

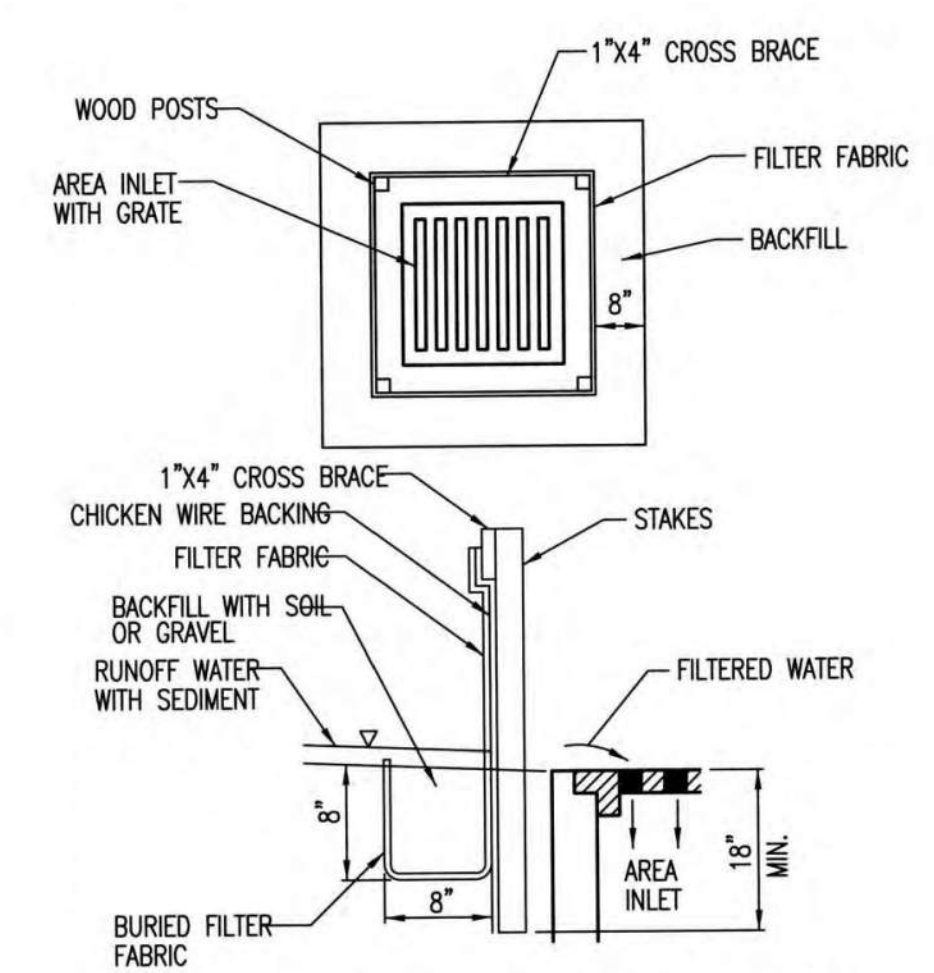

**SILT FENCE BARRIERS FOR AREA INLETS**  
(INLET PROTECTION)

**MATERIAL SPECIFICATION:**

SILT FENCE FABRIC SHOULD CONFORM TO THE AASHTO M288 96 SILT FENCE SPECIFICATION. THE WIRE OR POLYMERIC MESH BACKING USED TO HELP SUPPORT THE SILT FENCE FABRIC SHOULD CONFORM TO THE AASHTO M288 96 SILT FENCE SPECIFICATION. THE POSTS USED TO SUPPORT THE SILT FENCE FABRIC SHOULD BE A HARDWOOD MATERIAL WITH THE FOLLOWING MINIMUM DIMENSIONS: 2" SQUARE (NOMINAL) BY 4' LONG. THE MATERIAL USED TO FRAME THE TOPS OF THE POSTS SHOULD BE 1" BY 4" BOARDS. SILT FENCE FABRIC AND SUPPORT BACKING SHOULD BE ATTACHED TO THE WOODEN POSTS AND FRAME WITH STAPLES, WIRE, ZIP TIES, OR NAILS.

**PLACEMENT:**

PLACE A SILT FENCE DROP INLET BARRIER IN A LOCATION WHERE IT IS UNLIKELY TO BE OVERTOPPED. WATER SHOULD FLOW THROUGH SILT FENCE, NOT OVER IT. SILT FENCE BARRIERS FOR AREA INLETS OFTEN FAIL WHEN REPEATEDLY OVERTOPPED. WHEN USED AS A BARRIER FOR AREA INLETS, SILT FENCE FABRIC AND POSTS MUST BE SUPPORTED AT THE TOP BY A WOODEN FRAME. WHEN A SILT FENCE BARRIER FOR AREA INLETS IS LOCATED NEAR AN INLET THAT HAS STEEP APPROACH SLOPES, THE STORAGE CAPACITY BEHIND THE BARRIER IS DRASTICALLY REDUCED. TIMELY REMOVAL OF SEDIMENT MUST OCCUR FOR A BARRIER TO OPERATE PROPERLY IN THIS LOCATION.

**PROPER INSTALLATION METHOD:**

EXCAVATE A TRENCH AROUND THE PERIMETER OF THE AREA INLET THAT IS AT LEAST 8" DEEP BY 8" WIDE. DRIVE POSTS TO A DEPTH OF AT LEAST 18" AROUND THE PERIMETER OF THE AREA INLET. THE DISTANCE BETWEEN POSTS SHOULD BE 4' OR LESS. IF THE DISTANCE BETWEEN TWO ADJACENT CORNER POSTS IS MORE THAN 4', ADD ANOTHER POST(S) BETWEEN THEM. CONNECT THE TOPS OF ALL THE POSTS WITH A WOODEN FRAME MADE OF 1" BY 4" BOARDS. USE NAILS OR SCREWS FOR FASTENING. ATTACH THE WIRE OR POLYMERIC-MESH BACKING TO THE OUTSIDE OF THE POST/FRAME STRUCTURE WITH STAPLES, WIRE, ZIP TIES, OR NAILS. ROLL OUT A CONTINUOUS LENGTH OF SILT FENCE FABRIC LONG ENOUGH TO WRAP AROUND THE PERIMETER OF THE AREA INLET. ADD MORE LENGTH FOR OVERLAPPING THE FABRIC JOINT. PLACE THE EDGE OF THE FABRIC IN THE TRENCH, STARTING AT THE OUTSIDE EDGE OF THE TRENCH. LINE ALL THREE SIDES OF THE TRENCH WITH THE FABRIC. BACKFILL OVER THE FABRIC IN THE TRENCH WITH THE EXCAVATED SOIL AND COMPACT. AFTER FILLING THE TRENCH, APPROXIMATELY 24" TO 36" OF SILT FENCE FABRIC SHOULD REMAIN EXPOSED. ATTACH THE SILT FENCE TO THE OUTSIDE OF THE POST/FRAME STRUCTURE WITH STAPLES, WIRE, ZIP TIES, OR NAILS. THE JOINT SHOULD BE OVERLAPPED TO THE NEXT POST.

NOTE: WHEN A SILT FENCE BARRIER FOR AREA INLET IS PLACED IN A SHALLOW MEDIAN DITCH, MAKE SURE THAT THE TOP OF THE BARRIER IS NOT HIGHER THAN THE PAVED ROAD. IN THIS CONFIGURATION, WATER MAY SPREAD ONTO THE ROADWAY CAUSING A HAZARDOUS CONDITION.

**LIST OF COMMON PLACEMENT/INSTALLATION MISTAKES TO AVOID:**

WATER SHOULD FLOW THROUGH A SILT FENCE BARRIER FOR AREA INLET—NOT OVER IT. PLACE A SILT FENCE BARRIER FOR AREA INLET IN A LOCATION WHERE IT IS UNLIKELY TO BE OVERTOPPED. SILT FENCE BARRIER FOR AREA INLETS OFTEN FAIL WHEN REPEATEDLY OVERTOPPED. DO NOT PLACE POSTS ON THE OUTSIDE OF THE SILT FENCE BARRIER FOR AREA INLET. IN THIS CONFIGURATION, THE FORCE OF THE WATER IS NOT RESTRICTED BY THE POSTS, BUT ONLY BY THE STAPLES (WIRE, ZIP TIES, NAILS, ETC.). THE SILT FENCE WILL RIP AND FAIL. DO NOT INSTALL SILT FENCE BARRIER FOR AREA INLETS WITHOUT FRAMING THE TOP OF THE POSTS. THE CORNER POSTS AROUND AREA INLETS ARE STRESSED IN TWO DIRECTIONS WHEREAS A NORMAL SILT FENCE IS ONLY STRESSED IN ONE DIRECTION. THIS ADDED STRESS REQUIRES MORE SUPPORT.

**INSPECTION AND MAINTENANCE:**

SILT FENCE BARRIER FOR AREA INLETS SHOULD BE INSPECTED EVERY 7 DAYS AND WITHIN 24 HOURS OF A RAINFALL OF 1/2" OR MORE. THE FOLLOWING IS A LIST OF QUESTIONS THAT SHOULD BE ADDRESSED DURING EACH INSPECTION:  
 DOES WATER FLOW UNDER THE SILT FENCE?  
 DOES THE SILT FENCE SAG EXCESSIVELY?  
 HAS THE SILT FENCE TORN OR BECOME DETACHED FROM THE POSTS?  
 DOES SEDIMENT NEED TO BE REMOVED FROM BEHIND THE AREA INLET BARRIER?

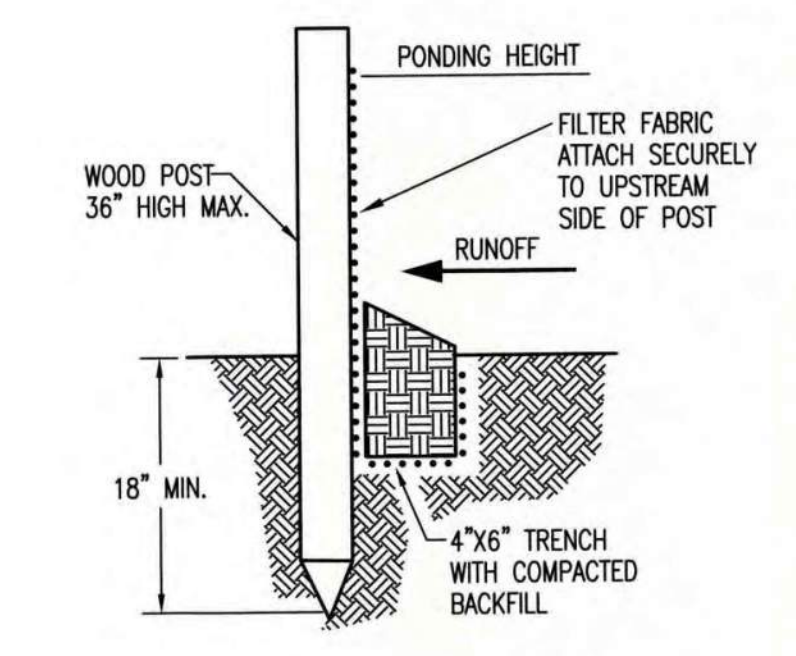

**SILT FENCE BARRIERS**

**MATERIAL SPECIFICATION:**

SILT FENCE FABRIC SHOULD CONFORM TO THE AASHTO M288 96 SILT FENCE SPECIFICATION. THE POSTS USED TO SUPPORT THE SILT FENCE FABRIC SHOULD BE A HARDWOOD MATERIAL WITH THE FOLLOWING MINIMUM DIMENSIONS: 2" SQUARE (NOMINAL) BY 4' LONG. SILT FENCE FABRIC SHOULD BE ATTACHED TO THE WOODEN POSTS WITH STAPLES, WIRE, ZIP TIES, OR NAILS.

**PLACEMENT:**

A SLOPE BARRIER SHOULD BE USED AT THE TOE OF A SLOPE WHEN A DITCH DOES NOT EXIST. THE SLOPE BARRIER SHOULD BE PLACED ON NEARLY LEVEL GROUND 5' TO 10' AWAY FROM THE TOE OF A SLOPE. THE BARRIER IS PLACED AWAY FROM THE TOE OF THE SLOPE TO PROVIDE ADEQUATE STORAGE FOR SETTLING OUT SEDIMENT. WHEN PRACTICABLE, SILT FENCE SLOPE BARRIERS SHOULD BE PLACED ALONG CONTOURS TO AVOID A CONCENTRATION OF FLOW. SILT FENCE SLOPE BARRIERS CAN ALSO BE PLACED ALONG RIGHT-OF-WAY FENCE LINES TO KEEP SEDIMENT FROM CROSSING ONTO ADJACENT PROPERTY. WHEN PLACED IN THIS MANNER, THE SLOPE BARRIER WILL NOT LIKELY FOLLOW CONTOURS.

**PROPER INSTALLATION METHOD:**

EXCAVATE A TRENCH THE LENGTH OF THE PLANNED SLOPE BARRIER THAT IS 6" DEEP BY 4" WIDE. MAKE SURE THAT THE TRENCH IS EXCAVATED ALONG A SINGLE CONTOUR. WHEN PRACTICABLE, SLOPE BARRIERS SHOULD BE PLACED ALONG CONTOURS TO AVOID A CONCENTRATION OF FLOW. PLACE THE SOIL ON THE UPSLOPE SIDE OF THE TRENCH FOR LATER USE. ROLL OUT A CONTINUOUS LENGTH OF SILT FENCE FABRIC ON THE DOWNSLOPE SIDE OF THE TRENCH. PLACE THE EDGE OF THE FABRIC IN THE TRENCH STARTING AT THE TOP UPSLOPE EDGE. LINE ALL THREE SIDES OF THE TRENCH WITH THE FABRIC. BACKFILL OVER THE FABRIC IN THE TRENCH WITH THE EXCAVATED SOIL AND COMPACT. AFTER FILLING THE TRENCH, APPROXIMATELY 24" TO 36" OF SILT-FENCE FABRIC SHOULD REMAIN EXPOSED. LAY THE EXPOSED SILT FENCE UPSLOPE OF THE TRENCH TO CLEAR AN AREA FOR DRIVING IN THE POSTS. JUST DOWNSLOPE OF THE TRENCH, DRIVE POSTS INTO THE GROUND TO A DEPTH OF AT LEAST 18". PLACE POSTS NO MORE THAN 4' APART. ATTACH THE SILT FENCE TO THE ANCHORED POST WITH STAPLES, WIRE, ZIP TIES, OR NAILS.

**LIST OF COMMON PLACEMENT/INSTALLATION MISTAKES TO AVOID:**

WHEN PRACTICABLE, DO NOT PLACE SILT FENCE SLOPE BARRIERS ACROSS CONTOURS. SLOPE BARRIERS SHOULD BE PLACED ALONG CONTOURS TO AVOID A CONCENTRATION OF FLOW. WHEN THE FLOW CONCENTRATES, IT OVERTOPS THE BARRIER AND THE SILT FENCE SLOPE BARRIER QUICKLY DETERIORATES. DO NOT PLACE SILT-FENCE POSTS ON THE UPSLOPE SIDE OF THE SILT FENCE FABRIC. IN THIS CONFIGURATION, THE FORCE OF THE WATER IS NOT RESTRICTED BY THE POSTS, BUT ONLY BY THE STAPLES (WIRE, ZIP TIES, NAILS, ETC.). THE SILT FENCE WILL RIP AND FAIL. DO NOT PLACE SILT FENCE SLOPE BARRIERS IN AREAS WITH SHALLOW SOILS UNDERLAIN BY ROCK. IF THE BARRIER IS NOT SUFFICIENTLY ANCHORED, IT WILL WASH OUT. SILT FENCE SLOPE BARRIERS MUST BE DUG INTO THE GROUND—SILT FENCE AT GROUND LEVEL DOES NOT WORK BECAUSE WATER WILL FLOW UNDERNEATH.

**INSPECTION AND MAINTENANCE:**

SILT FENCE SLOPE BARRIERS SHOULD BE INSPECTED EVERY 7 DAYS AND WITHIN 24 HOURS OF A RAINFALL OF 1/2" OR MORE. THE FOLLOWING IS A LIST OF QUESTIONS THAT SHOULD BE ADDRESSED DURING EACH INSPECTION:  
 ARE THERE ANY POINTS ALONG THE SLOPE BARRIER WHERE WATER IS CONCENTRATING?  
 DOES WATER FLOW UNDER THE SLOPE BARRIER?  
 DO THE SILT FENCES SAG EXCESSIVELY?  
 HAS THE SILT FENCE TORN OR BECOME DETACHED FROM THE POSTS?  
 DOES SEDIMENT NEED TO BE REMOVED FROM BEHIND THE SLOPE BARRIER?



 <b>CITY OF WICHITA</b> PUBLIC WORKS & UTILITIES ENGINEERING DIVISION			<b>SILT FENCE DITCH CHECK AND BARRIER DETAILS</b>		
			CITY ENGINEER <b>GARY JANZEN, P.E.</b>		
PROJECT NUMBER	OCA NUMBER	DATE	SHEET		
CITY ENGINEER'S OFFICE CITY HALL - SEVENTH FLOOR 455 NORTH MAIN STREET WICHITA, KANSAS 67202-1620 (316) 268-4501					

SW-502

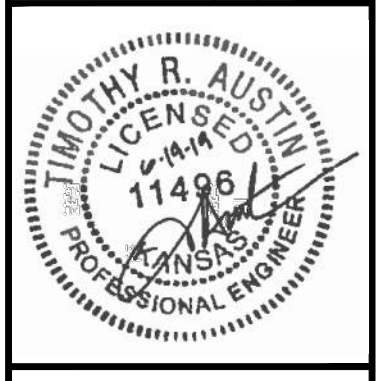

TIMOTHY R. AUSTIN  
ENGINEER  
KS # 11496

200 N. EMPORIA, SUITE 100  
WICHITA, KANSAS 67202-4400-4309  
PH: (316) 268-4501  
www.kawvalley.com | www.kaweng.com

**KAW VALLEY ENGINEERING**

KAW VALLEY ENGINEERING, INC. IS AUTHORIZED TO OFFER ENGINEERING SERVICES IN THE STATE OF KANSAS UNDER CERTIFICATE OF AUTHORIZATION # E-113. EXPIRES 12/31/20



REVISION DATE: MAY 2013

**BECK STORAGE**  
6220 S SENECA ST  
WICHITA, KS

**EROSION CONTROL DETAILS**

PROJ. NO.	G19_1053
DESIGNER	TRA
DRAWN BY	EAM
CFN	
SHEET	1053WDET
REV	
06	1







