

File: L:\2020\2021\006 - Legacy 3rd Addition Imp Last Phase\Drawings\C3D\Paving Sheets\2021\1006 MT. CARMEL AVE. (1).dwg Last Save: 2/2/2021 12:02 PM Last saved by: MCarreraPiedra
 Last plotted by: Carrera-Piedra, Mariela Plot Date: 2/2/2021 12:39 PM Plotter used: None

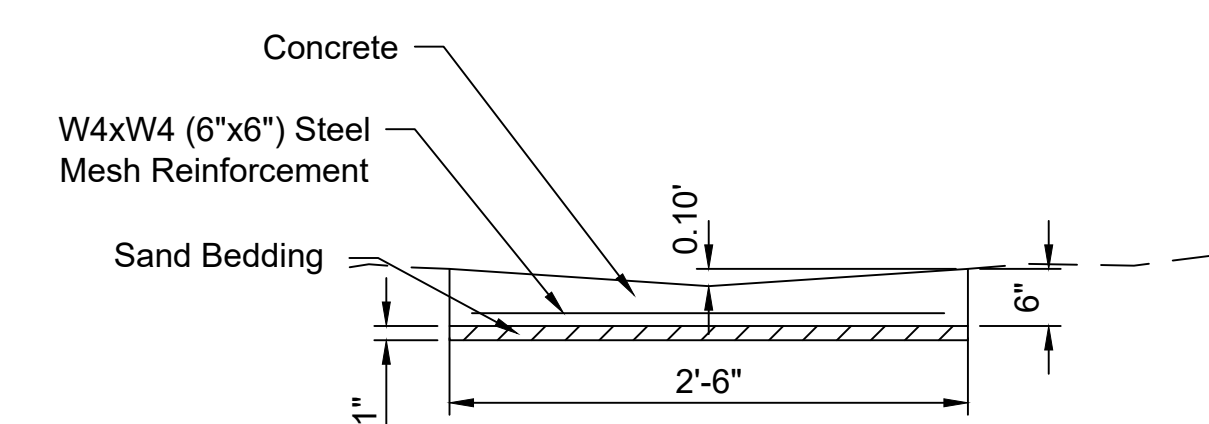

CONCRETE DRAIN DETAIL
 NOT TO SCALE

NOTE:
 1. EARTHWORK SHALL BE FILLED OR EXCAVATED TO ENSURE FLUME MEETS PROPOSED ELEVATIONS.
 2. CONTRACTOR SHALL FIELD ADJUST FLUME TO MATCH SHAPE OF ROLL CURB AT THE END OF PAVEMENT.

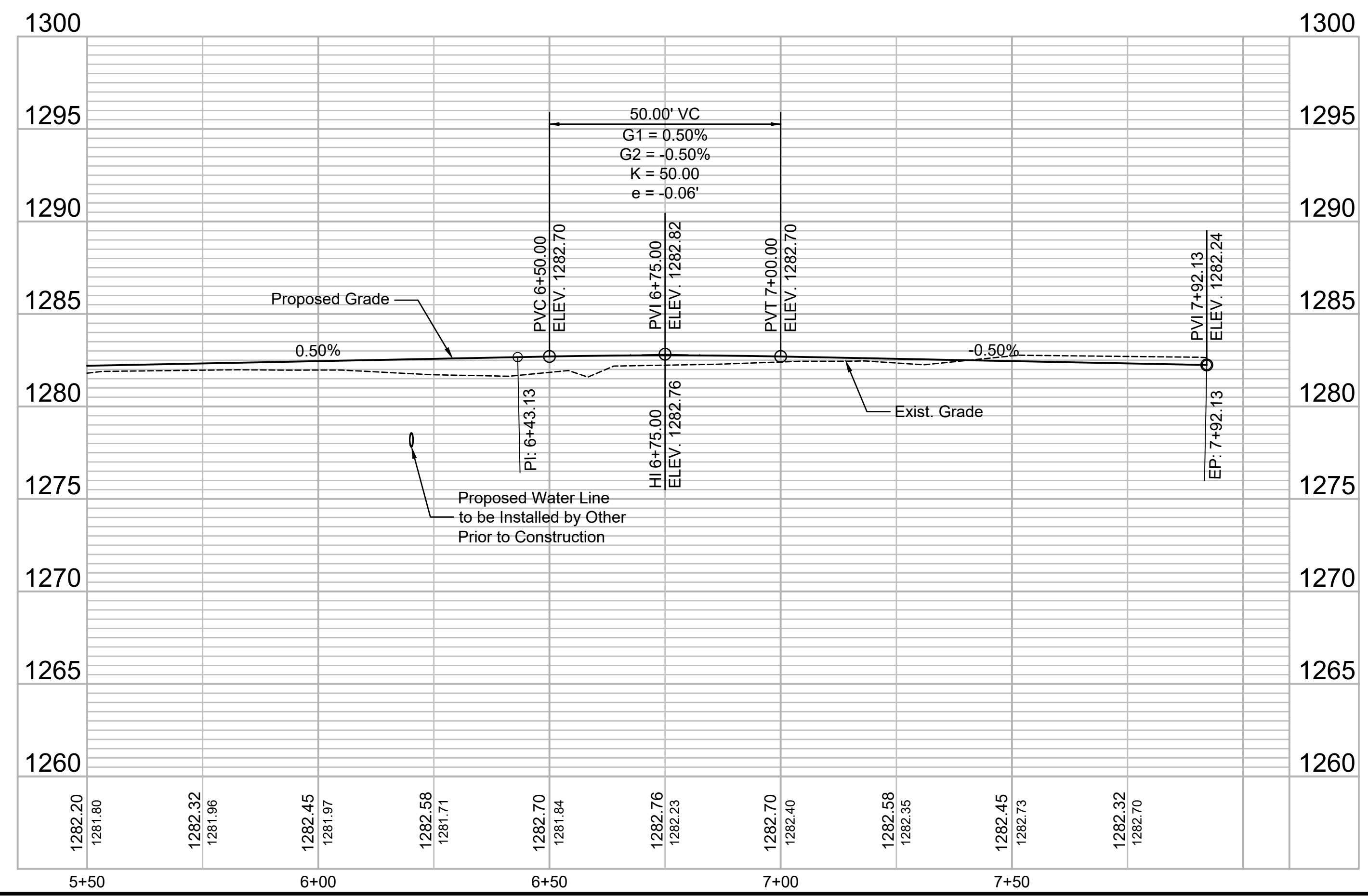
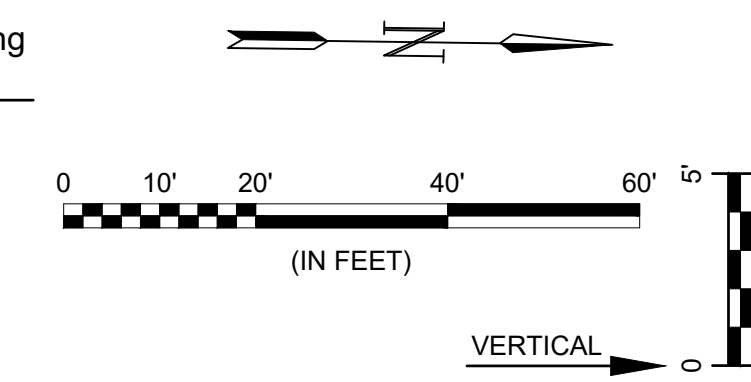
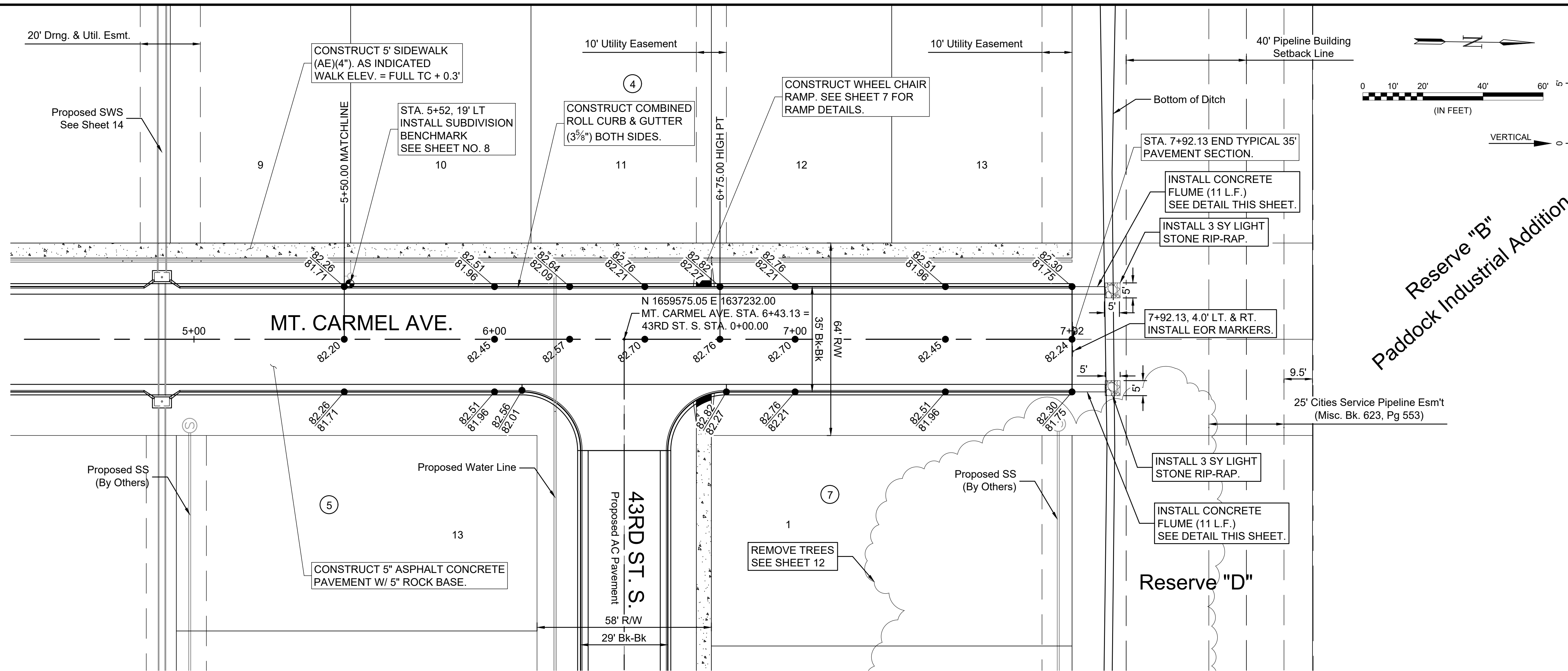

© 2021 GARVER, LLC
 THIS DOCUMENT, ALONG WITH THE IDEAS AND DESIGNS CONVEYED HEREIN, SHALL BE CONSIDERED INSTRUMENTS OF PROFESSIONAL SERVICE AND ARE PROPERTY OF GARVER, LLC. ANY USE, REPRODUCTION, OR DISTRIBUTION OF THIS DOCUMENT, ALONG WITH THE IDEAS AND DESIGN CONTAINED HEREIN, IS PROHIBITED UNLESS AUTHORIZED IN WRITING BY GARVER, LLC OR EXPLICITLY ALLOWED IN THE GOVERNING PROFESSIONAL SERVICES AGREEMENT FOR THIS WORK.

8535 E. 21st Street N.
 Suite 130
 Wichita, KS 67206
 (316) 264-8008



REV.	DATE	DESCRIPTION	BY



CITY OF WICHITA
 WICHITA, KANSAS

LEGACY 3RD
 ADDITION
 PAVING

MT. CARMEL
 AVE. (2 of 2)

JOB NO.: 20T41006
 DATE: Feb 2021
 DESIGNED BY: #
 DRAWN BY: #

BAR IS ONE INCH ON ORIGINAL DRAWING
 IF NOT ONE INCH ON THIS SHEET, ADJUST SCALES ACCORDINGLY.

DRAWING NUMBER

SHEET NUMBER **10** OF **24**