

NOTE: Toe plate, where specified, to be punched to match holes in apron lip. 3/8" Dia. galvanized bolts to be furnished. The length of toe plate to be as follows:
 W + 10" for 12" to 30" diameter pipes inclusive.
 W + 20" for 36" to 84" diameter pipes inclusive.
 W + 10" for pipe-arches with a rise of 13" to 29" inclusive.
 W + 20" for pipe-arches with a rise of 33" to 59" inclusive.

Apron section for 12" to 24" diameter pipe inclusive, and pipe-arches with rise of 13" to 24" inclusive, to be made from one sheet. Apron sections for 30" to 42" diameter pipe inclusive, and pipe-arches with rise of 29" to 33" inclusive, may be made from up to two sheets joined by riveting or bolting on the centerline apron section. Apron section for 48" to 72" diameter pipe inclusive, and pipe-arches with rise of 38" to 63" inclusive, may be made from up to three sheets joined by riveting or bolting at equal distances from centerline. Apron sections for 78" diameter pipe and above and pipe-arches with rise 67" and above may be made from up to four sheets joined by riveting or bolting.

Corner sections, corner plate and toe plate to be same gauge as apron and each to be galvanized in accordance with the specifications.
 Other approved designs may be used in lieu of type shown.

| Bid Designation Sq. Ft. | Nom. W.W. Area Sq. Ft. | Pipe Arch | | Min. Gauge End Sect. | Dimensions in Inches | | | | | No. Apron Panels | Slope |
|---------------------------------------|------------------------|------------|------------|----------------------|----------------------|---------|-----------|-------------|-----------|------------------|---------|
| | | Span (In.) | Rise (In.) | | A 1" Tol. | B Max. | H 1" Tol. | L 1/2" Tol. | W 2" Tol. | | |
| 1.0 | 1.1 | 17 | 13 | 16 | 7 | 9 | 6 | 19 | 30 | 1 | 2 1/2:1 |
| 1.5 | 1.6 | 21 | 15 | 16 | 7 | 10 | 6 | 23 | 36 | 1 | 2 1/2:1 |
| 2.0 | 2.2 | 24 | 18 | 16 | 8 | 12 | 6 | 28 | 42 | 1 | 2 1/2:1 |
| 2.5 | 2.8 | 28 | 20 | 16 | 9 | 14 | 6 | 32 | 48 | 1 | 2 1/2:1 |
| Sizes below with alternate dimensions | | | | | | | | | | | |
| 3.0 or 4.0 | 4.4 | 35 | 24 | 14 | 10 | 16 | 6 & 8 | 39 | 60 | 1 | 2 1/2:1 |
| 5.0 or 6.0 | 6.4 | 42 | 29 | 14 | 12 | 18 | 8 & 9 | 46 | 75 | 2 | 2 1/2:1 |
| 7.0 or 8.5 | 8.7 | 49 | 33 | 12 | 13 | 21 | 9 & 12 | 53 | 85 | 2 | 2 1/2:1 |
| 10.0 or 11.0 | 11.4 | 57 | 38 | 12 | 18 | 26 | 12 | 63 | 90 | 2 | 2 1/2:1 |
| 12.5 or 14.0 | 15.6 | 60 | 46 | 12 | 18 | 30 & 34 | 12 | 70 | 102 | 2 | 2:1 |
| 16.5 | 19.3 | 66 | 51 | 12 & 10 | 18 | 33 | 12 | 77 | 114 & 116 | 3 | 1 1/2:1 |
| 21.0 | 23.2 | 73 | 55 | 12 & 10 | 18 | 36 | 12 | 77 | 126 | 3 | 1 1/2:1 |
| 25.0 | 27.4 | 81 | 59 | 12 & 10 | 18 | 39 | 12 | 77 | 138 | 3 | 1 1/2:1 |
| 32.0 | 32.1 | 87 | 63 | 12 & 10 | 22 | 38 | 12 | 77 | 148 | 3 | 1 1/2:1 |
| 36.0 | 37.0 | 95 | 67 | 12 & 10 | 22 | 34 | 12 | 77 | 162 | 3 | 1 1/2:1 |
| 42.0 | 42.4 | 103 | 71 | 12 & 10 | 22 | 38 | 12 | 77 | 174 | 3 | 1 1/2:1 |
| 47.0 | 48.0 | 112 | 75 | 12 & 10 | 24 | 40 | 12 | 77 | 174 | 3 | 1 1/2:1 |

| Pipe Dia. (In.) | Min. Gauge Ends | Dimensions in Inches | | | | | No. Apron Panels | Slope |
|-----------------|-----------------|----------------------|---------|-----------|-------------|-----------|------------------|---------|
| | | A 1" Tol. | B Max. | H 1" Tol. | L 1/2" Tol. | W 2" Tol. | | |
| 12" | 16 | 6 | 6 | 6 | 21 | 24 | 1 | 2 1/2:1 |
| 15" | 16 | 7 | 8 | 6 | 26 | 30 | 1 | 2 1/2:1 |
| 18" | 16 | 8 | 10 | 6 | 31 | 36 | 1 | 2 1/2:1 |
| 21" | 16 | 9 | 12 | 6 | 36 | 42 | 1 | 2 1/2:1 |
| 24" | 16 | 10 | 13 | 6 | 41 | 48 | 1 | 2 1/2:1 |
| 30" | 14 | 12 | 16 | 8 | 51 | 60 | 1 | 2 1/2:1 |
| 36" | 14 | 14 | 19 | 9 | 60 | 72 | 2 | 2 1/2:1 |
| 42" | 12 | 16 | 22 | 11 | 69 | 84 | 2 | 2 1/2:1 |
| 48" | 12 | 18 | 27 | 12 | 78 | 90 | 2 | 2 1/2:1 |
| 54" | 12 | 18 | 30 | 12 | 84 | 102 | 2 | 2 1/2:1 |
| 60" | 12 & 10 | 18 | 33 | 12 | 87 | 114 | 3 | 2:1 |
| 66" | 12 & 10 | 18 | 36 | 12 | 87 | 120 | 3 | 2:1 |
| 72" | 12 & 10 | 18 | 39 | 12 | 87 | 126 | 3 | 2:1 |
| 78" | 12 & 10 | 18 | 42 | 12 | 87 | 132 | 3 | 1 1/2:1 |
| 84" | 12 & 10 | 18 | 45 | 12 | 87 | 138 | 3 | 1 1/2:1 |
| 90" | 12 & 10 | 18 & 24 | 37 & 45 | 11 & 12 | 87 | 138 & 144 | 3 | 1 1/2:1 |
| 96" | 12 & 10 | 18 & 25 | 35 & 45 | 12 | 87 | 138 & 150 | 3 | 1 1/2:1 |

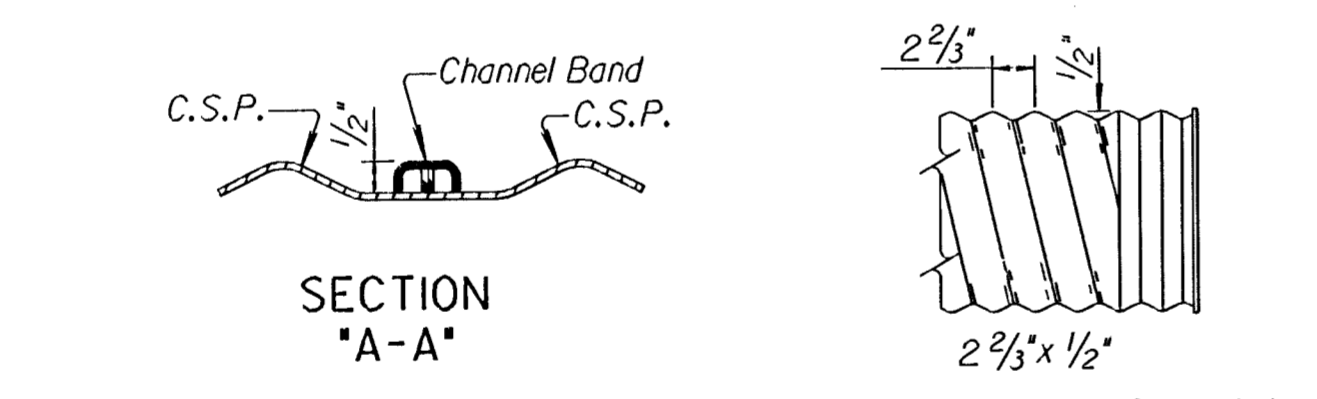
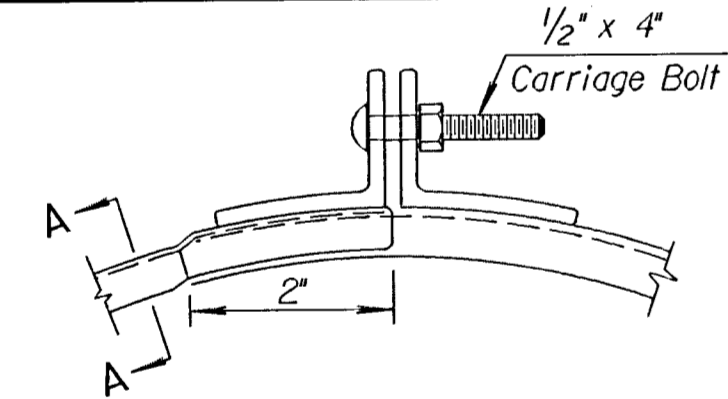

Channel band couplers shall:
 1. Be of two piece design.
 2. Be fabricated from galvanized steel stock.
 3. Be 14 ga. thickness for pipe 12 ga. or lighter. (A= 3/4")
 4. Be 12 ga. thickness for pipe 10 ga. or heavier. (A= 1")
 5. Have 2" x 2" x 3/16" angles securely fastened to the band ends to allow for proper tightening.

| Pipe Dia. Inches | * Minimum Gauge of Pipe | | | | |
|------------------|---------------------------|---------------------|---------------------|---------------------|-------|
| | 2 2/3" x 1/2" Corr. Steel | 3" x 1" Corr. Steel | 6" x 2" Corr. Steel | 6" x 1" Corr. Steel | Alum. |
| 12" | 16 | 16 | | | |
| 15" | 16 | 16 | | | |
| 18" | 16 | 16 | | | |
| 21" | 16 | 16 | | | |
| 24" | 14 | 14 | | | |
| 30" | 14 | 12 | | | |
| 36" | 14 | 12 | | | 16 |
| 42" | 12 | 12 | 14 | | 16 |
| 48" | 12 | 10 | 14 | | 16 |
| 54" | 12 | 10 | 14 | | 16 |
| 60" | 10 | 8 | 14 | 12 | 16 |
| 66" | 10 | 8 | 14 | 12 | 16 |
| 72" | 10 | 6 | 14 | 12 | 14 |
| 78" | 8 | | 14 | 12 | 12 |
| 84" | | | 12 | 12 | 12 |
| 90" | | | 12 | 12 | |
| 96" | | | 12 | 12 | |
| 102" | | | 12 | 12 | |
| 108" | | | 10 | 12 | |
| 114" | | | 10 | 12 | |
| 120" | | | 10 | 12 | |

| Bid Designation Sq. Ft. | Pipe Dimension Span & Rise | Sq. Ft. | * Min. Gauge of Pipe | | |
|-------------------------|----------------------------|---------|---------------------------|---------------------|-------|
| | | | 2 2/3" x 1/2" Corr. Steel | 3" x 1" Corr. Steel | Alum. |
| 1.0 | 17" x 13" | 1.1 | 16 | 16 | |
| 1.5 | 21" x 15" | 1.6 | 16 | 16 | |
| 2.0 | 24" x 18" | 2.2 | 16 | 16 | |
| 2.5 | 28" x 20" | 2.8 | 14 | 14 | |
| 3.0 or 4.0 | 35" x 24" | 4.4 | 14 | 12 | |
| 5.0 or 6.0 | 42" x 29" | 6.4 | 14 | 12 | |
| 7.0 or 8.5 | 49" x 33" | 8.7 | 12 | 12 | |
| 10.0 or 11.0 | 57" x 38" | 11.4 | 12 | 10 | |
| 12.5 or 14.0 | 60" x 46" | 15.6 | 10 | 14 | |
| 16.5 | 66" x 51" | 19.3 | 8 | 14 | |
| 21.0 | 73" x 56" | 23.2 | | 12 | |
| 25.0 | 81" x 59" | 27.4 | | 12 | |
| 32.0 | 87" x 63" | 32.1 | | 12 | |
| 36.0 | 96" x 67" | 37.0 | | 12 | |
| 42.0 | 103" x 71" | 42.4 | | 12 | |
| 47.0 | 112" x 75" | 48.0 | | 12 | |
| 54.0 | 117" x 79" | 54.2 | | 10 | |
| 60.0 | 128" x 83" | 60.5 | | 10 | |
| 67.0 | 137" x 87" | 67.4 | | 10 | |
| 74.0 | 142" x 91" | 74.5 | | 10 | |

Note: The culverts listed on this sheet may not indicate that the culvert installed will be steel, aluminum or reinforced concrete.
 * For gauge above minimum requirements see summary of culverts.

Connection of end sections by welding will not be permitted. All 3 piece apron sections shall have 12 gauge sides and 10 gauge center panels. Multiple panel apron sections shall have lap seams which are to be tightly jointed by galvanized rivets or bolts at equal distances from center line.

For 60" to 120" diameter pipe apron sections, reinforced edges to be supplemented by hot dipped galvanized stiffener angles. The angles to be attached by galvanized nuts and bolts.

For 73" x 55" and larger pipe-arch sections, reinforced edges to be supplemented by hot dipped galvanized stiffener angles. The angles to be attached by galvanized bolts and nuts.

Angle reinforcement shall be placed under the center panel seams on 73" x 55" and larger pipe arch apron sections.

All references to galvanized metal refer to steel only. Gain in pipe length due to fit of pipe at connecting band shall not be paid for.

When Hugger Bands are used the H-7 Hugger Band may be used on circular pipes 36" diameter and smaller and pipe arches 42" x 29" and smaller. The H-10 Hugger Band is required for larger size pipes.

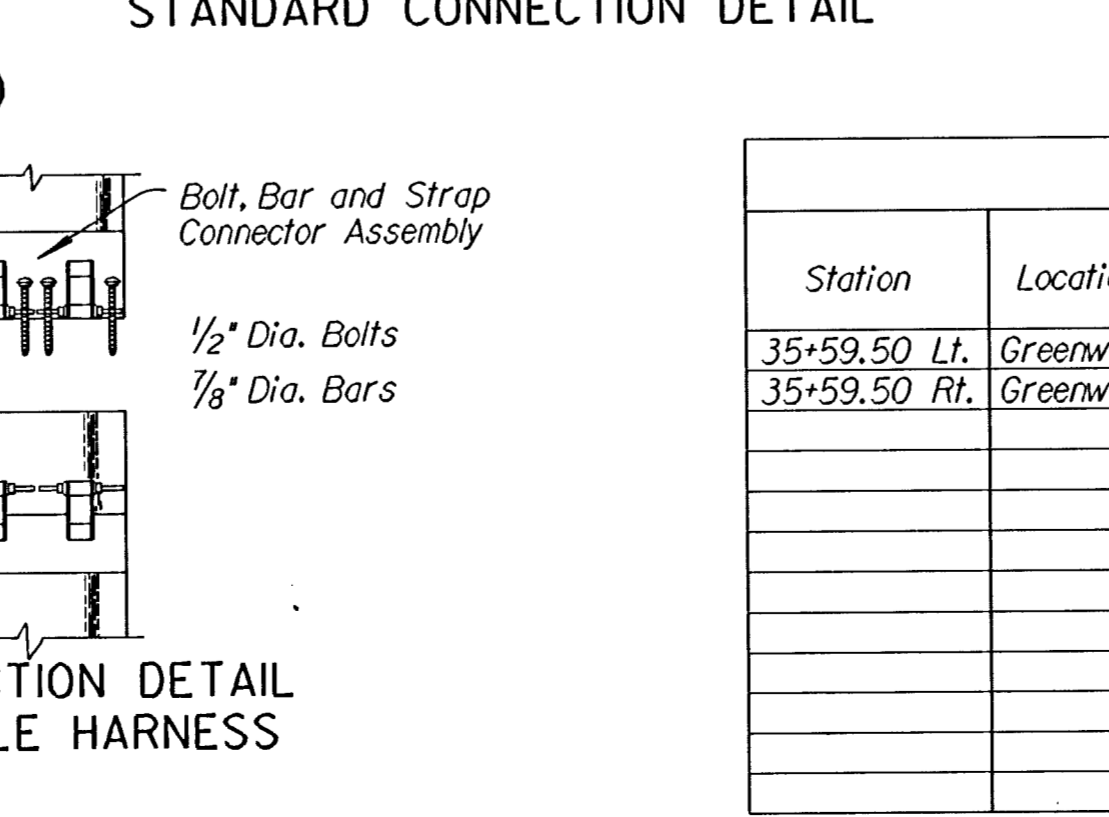
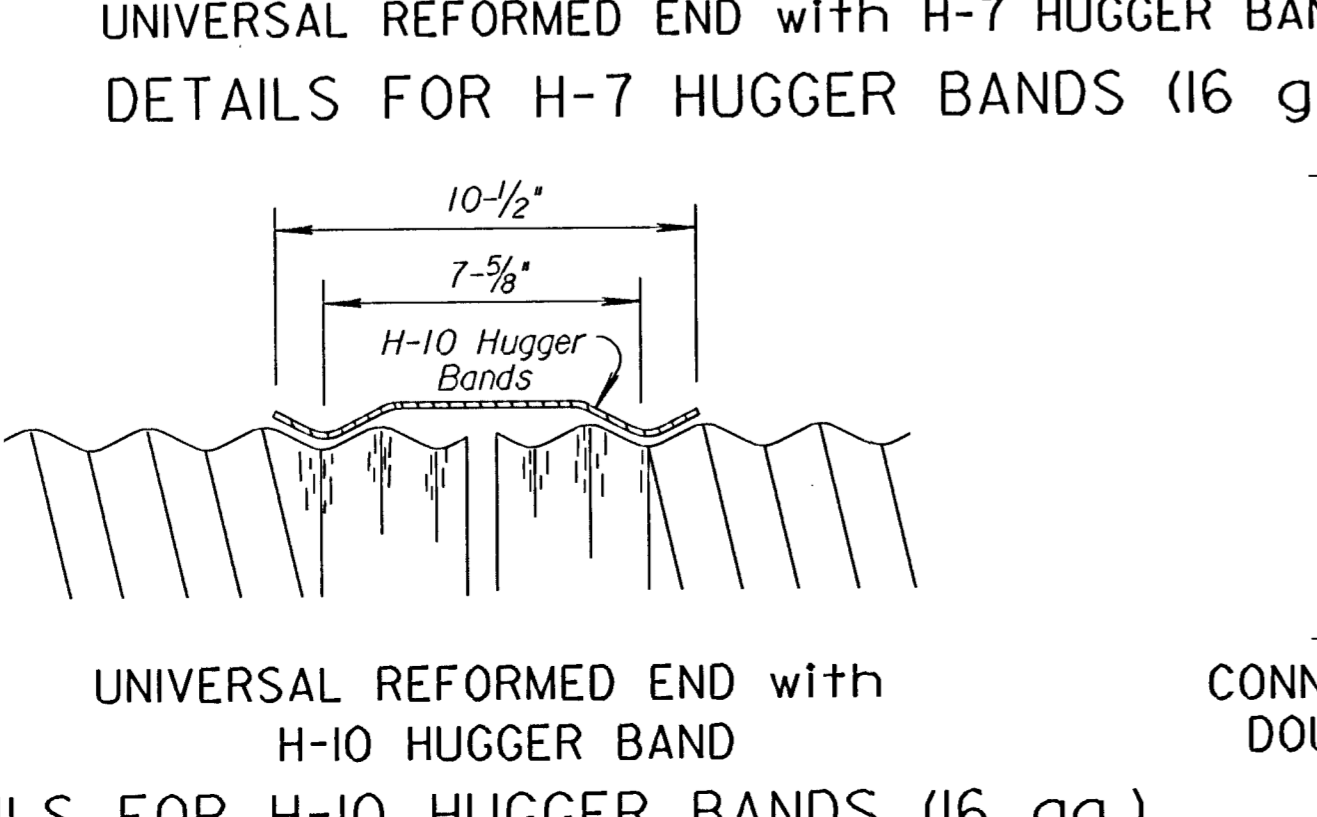
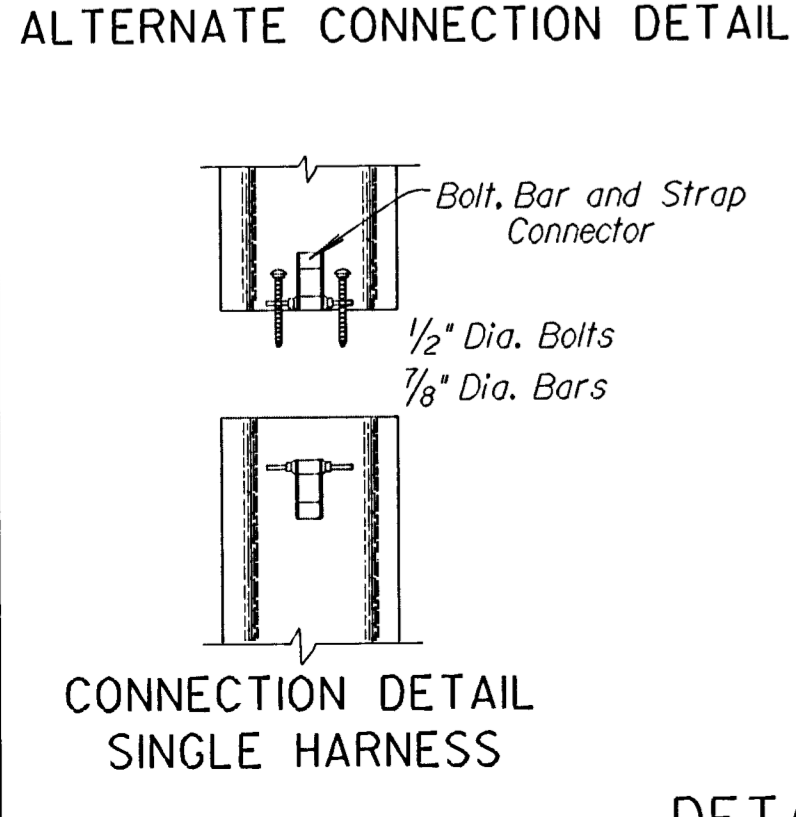
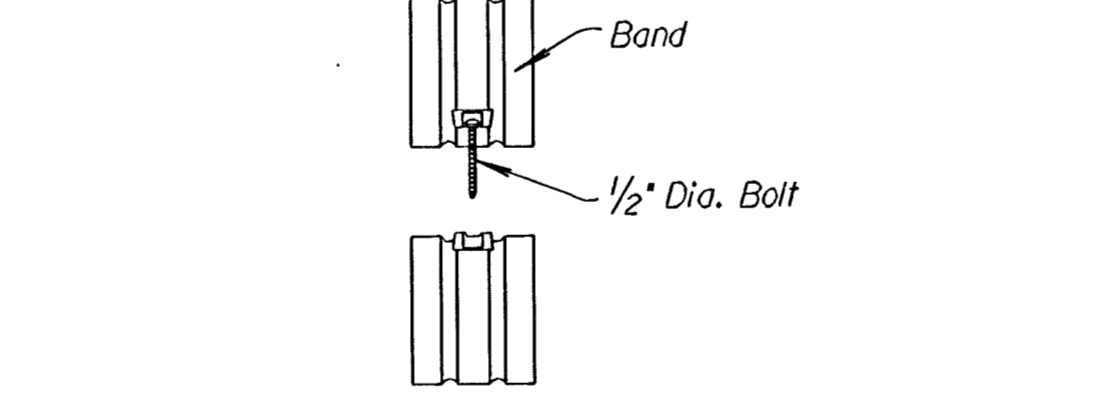
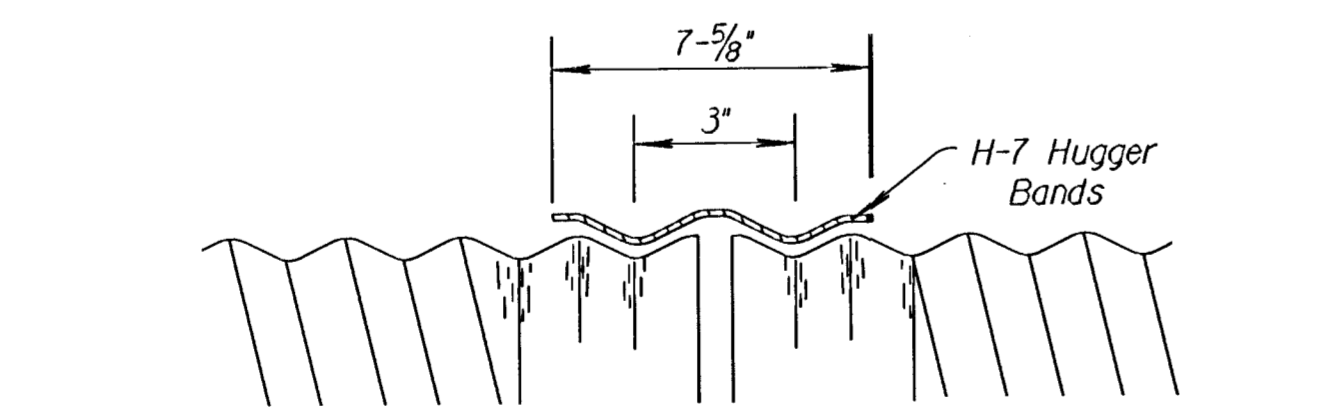
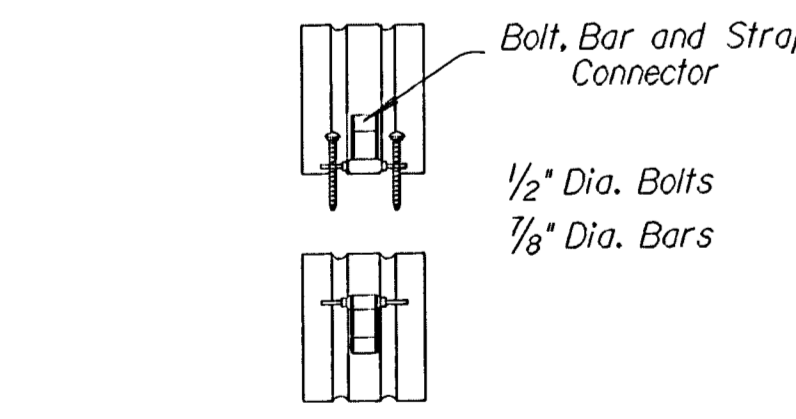

| Station | Location | Type | Size or Bid Designation Sq. Ft. | Crown Grade Elev. | Flow Line | | Horizontal Roadway | | Degree of Rotation | Length of Pipe | | Lin. Ft. of Pipe | End Sections Type I Lt. Rt. Lt. Rt. | | |
|----------|---------------|------|---------------------------------|-------------------|-----------|---------|--------------------|-------|--------------------|----------------|-----|------------------|-------------------------------------|-----|-----|
| | | | | | Lt. | Rt. | Lt. | Rt. | | Lt. | Rt. | | Lt. | Rt. | |
| | | | | | Lt. | Rt. | Lt. | Rt. | | Lt. | Rt. | | Lt. | Rt. | |
| 35+59.50 | Lt. Greenwich | 2 | 57" x 38" | 1373.37 | 1364.38 | --- | 47.00 | --- | 15 | 18' | 36 | --- | --- | 2 | --- |
| 35+59.50 | Rt. Greenwich | 2 | 57" x 38" | 1373.37 | --- | 1365.72 | --- | 41.00 | 0 | --- | 12' | 24 | --- | 2 | --- |

Beveled End Sections

| NO. | DATE | REVISIONS | BY | APP'D |
|-----|------|-----------|----|-------|
| | | | | |

KANSAS DEPARTMENT OF TRANSPORTATION

METAL END SECTION FOR ROUND & ARCH METAL CULVERTS (TYPE I) & PIPE GAUGE TABLES

RD660

| | | |
|---------------|------------|------------------------|
| FHWA APPROVAL | 1-6-92 | APP'D. James O. Brewer |
| DESIGNED | QUANTITIES | TRACED |
| DESIGN CK. | DETAIL CK. | QUAN. CK. |
| | | TRACE CK. Seitz |

Drawn By: K001
 Plotted by: D.J.W. 11-5-97
 DGN File: 11/1995/95297/002/standard/r660.dgn