

The Striping Contractor may be required to adjust the proposed pavement markings to match the existing pavement markings in the field. The Contractor may also be required to remove and replace the existing pavement markings as necessary, including those removed for traffic control beyond the construction limits. These cost shall be SUBSIDIARY to the Lump Sum Bid Item "Pavement Marking".

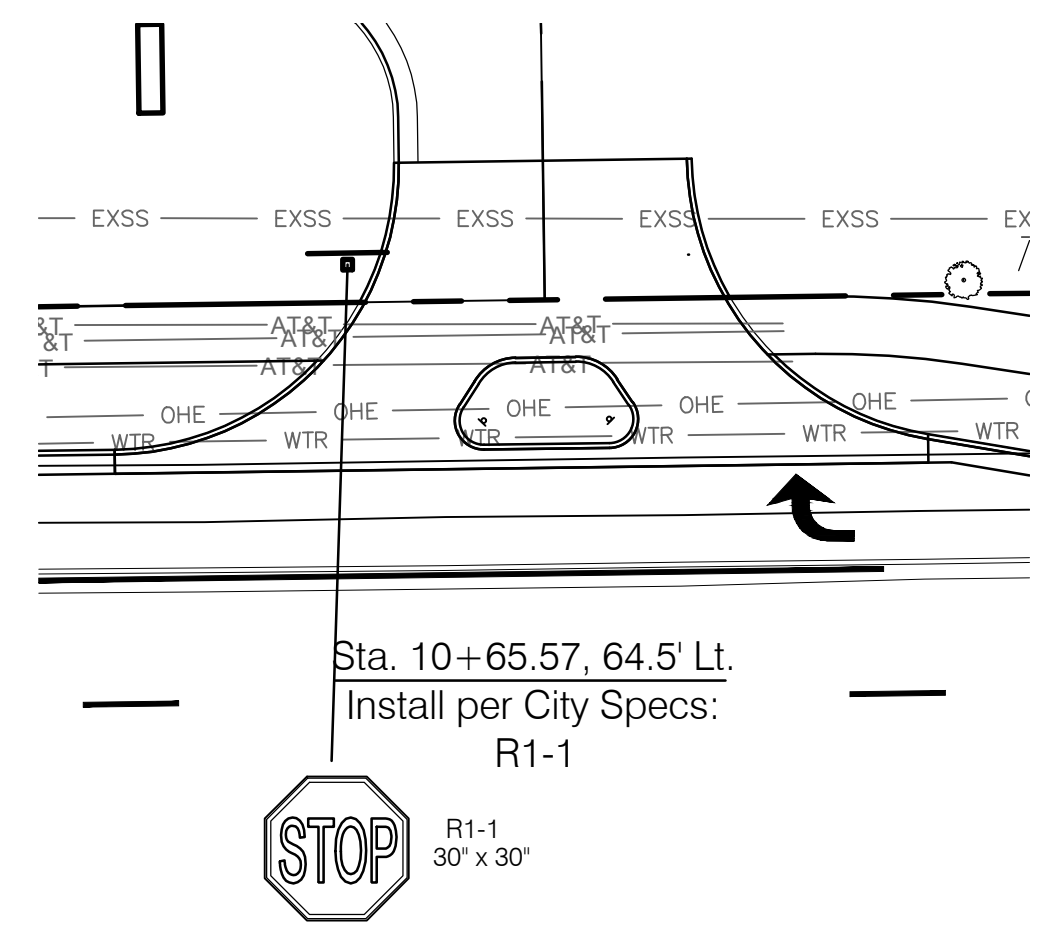

DRIVE ENTRANCE DETAIL

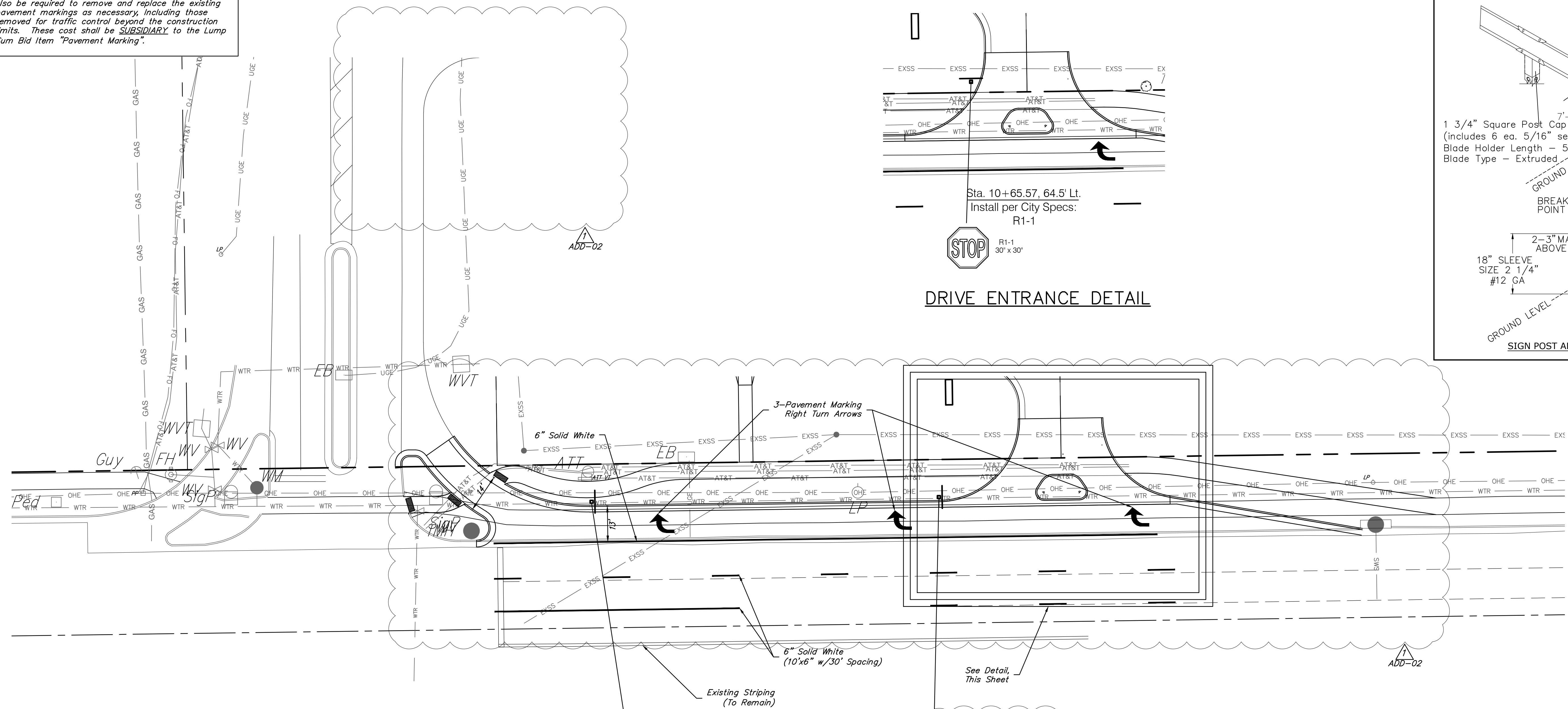
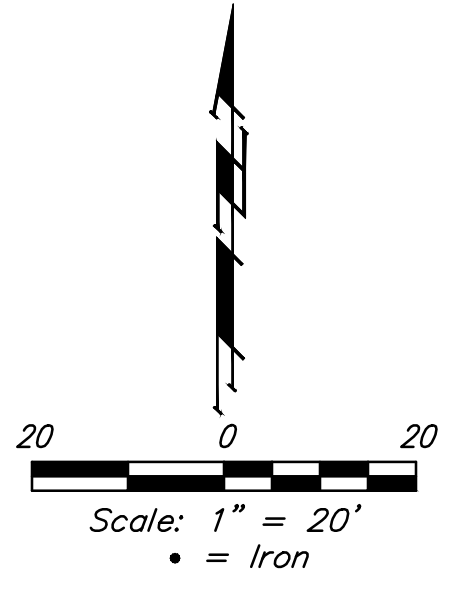
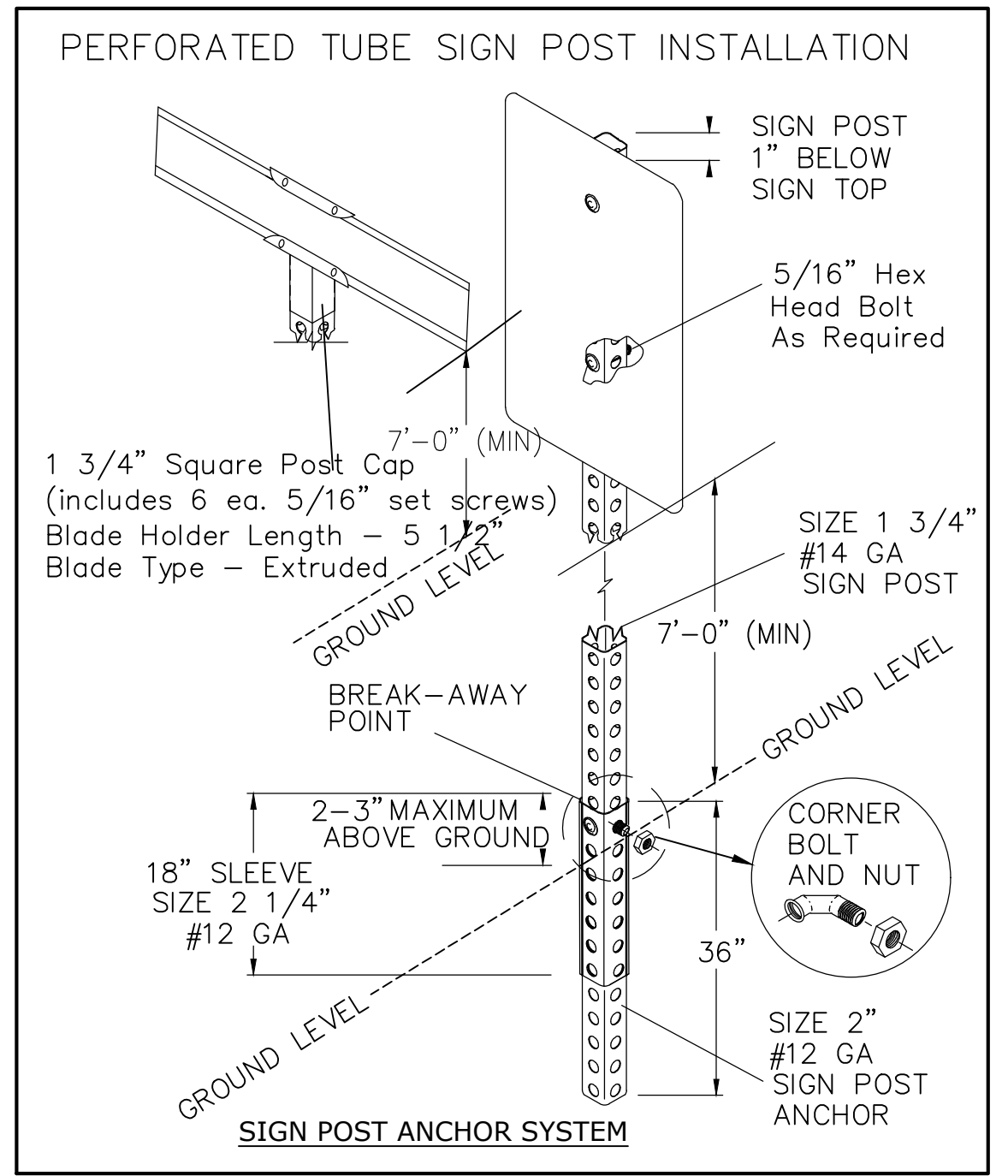

GENERAL NOTES – MARKING

- All pavement markings shall conform to the current standards set forth in the latest publication of the "Manual on Uniform Traffic Control Devices" 2009 Edition.
- All pavement markings shall be thermoplastic, unless otherwise approved by the Engineer. Pavement markings shall be installed per manufacturer's recommendations and shall meet KDOT's 2007 Standard Specification. Full traffic may not be restored (and substantial project completion achieved) until all pavement markings are in place. Should construction timing be such that restoration of traffic becomes necessary during temperatures prohibiting the installation of thermoplastic markings, the contractor shall install and maintain temporary markings until such time that thermoplastic markings may be properly installed. Except for the material requirement, temporary pavement markings shall be placed equivalent, in every manner (i.e. dimension, frequency, spacing, etc.), to the permanent marking layout. The cost for temporary pavement markings will not be paid for directly, but shall be considered SUBSIDIARY to the bid item "Pavement Marking".

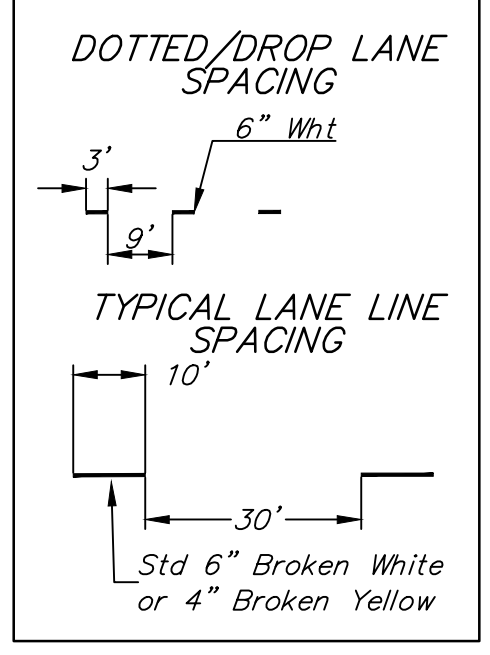

Sta. 9+12.93, 47.0' Lt.
Install per City Specs:
R3-7R



Sta. 10+36.07, 47.0' Lt.
Install per City Specs:
R3-7R



TOTAL PROJECT BILL OF MATERIALS*

ITEMS	UNITS	TOTAL	USE*
6" WHITE	LF	423	437
MARKING SYMBOL (RT TURN ARROW) WHITE	EA	3	3

*FOR INFORMATION ONLY

* ±3% Overage

BAUGHMAN COMPANY

315 Ellis St.
Wichita, KS 67211
316-262-7271
BaughmanCo.com

NEWSPRING
COMMERCIAL ADDITION

MARKING & SIGNING PLAN

SIDEWALK & TURN
LANE IMPROVEMENTS

PROJECT NUMBER:
20-10-E760

DESIGN: SRS DRAWN: SRS
DATE: August 20, 2021

SHEET **7** OF **21**

File: E:\Projects\NewSpring Commercial Addition\Engineering\Phase 1\STR\NSA STR Rev1.dwg