

EXPANSION JOINT

NOTE: Extra Thickness to be Subsidiary to Price of Square Yards Pavement

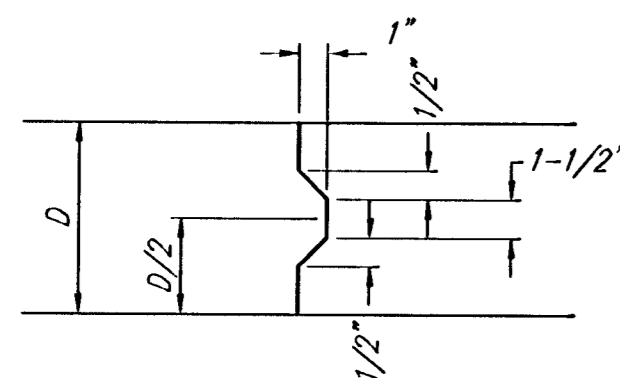

KEYWAY DETAIL

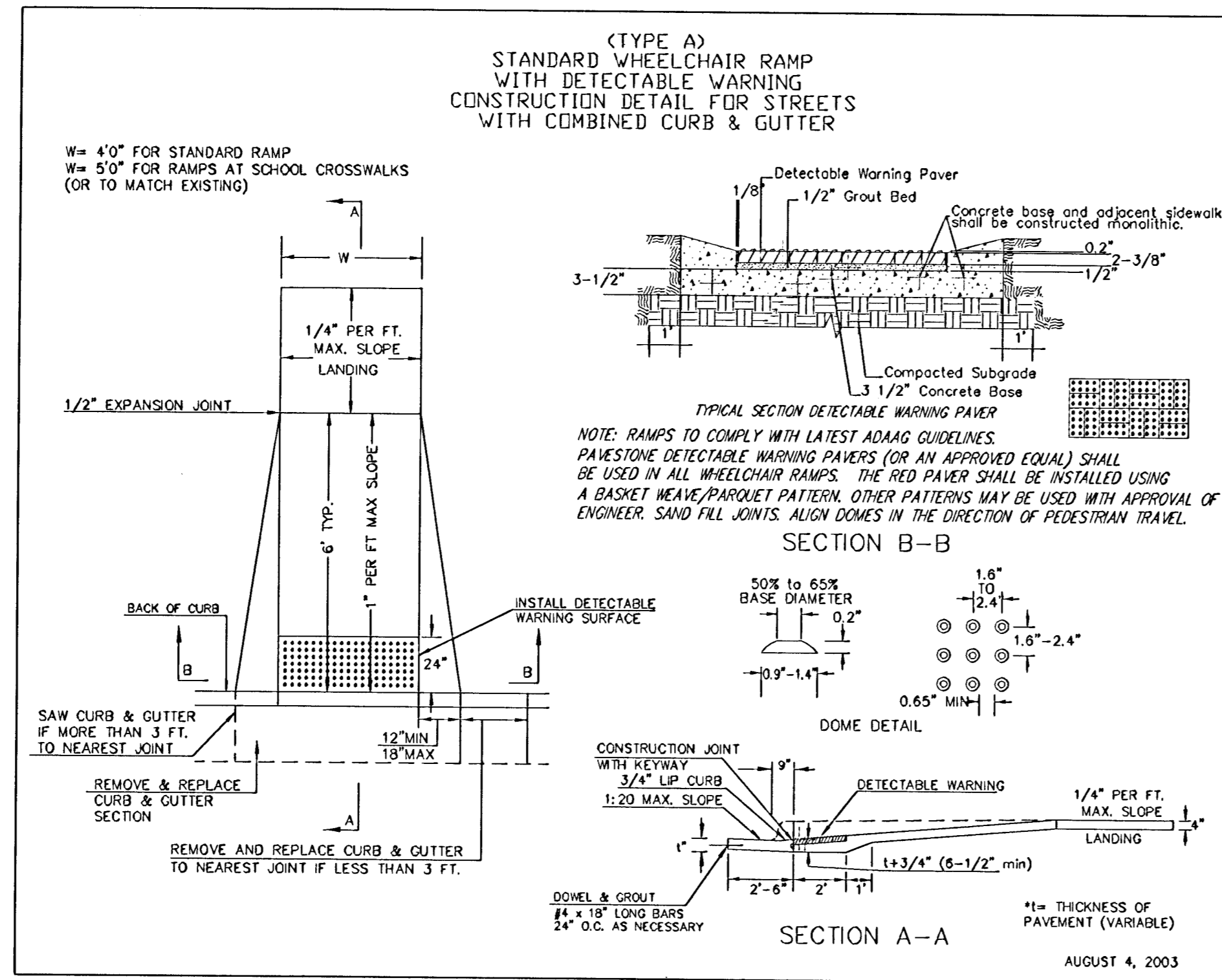

WHEELCHAIR RAMP DETAIL

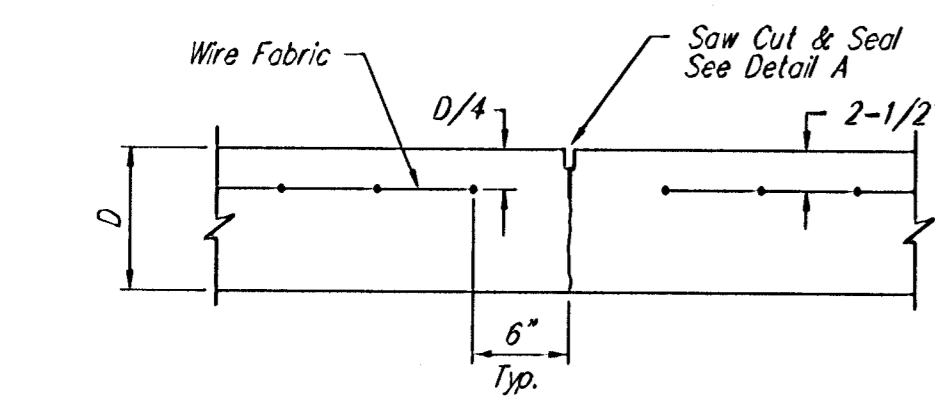
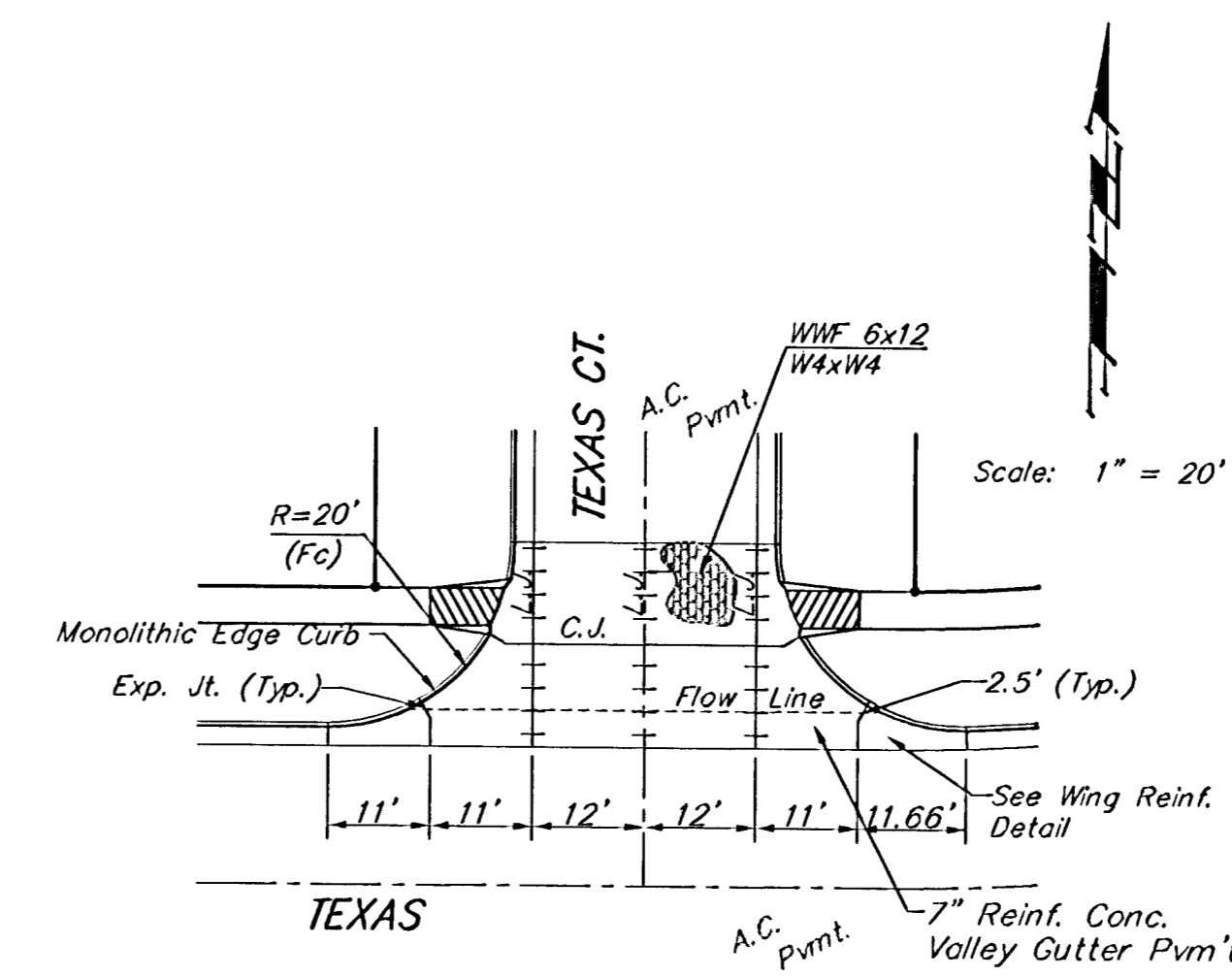

CONTRACTION JOINT DETAIL (C.J.)

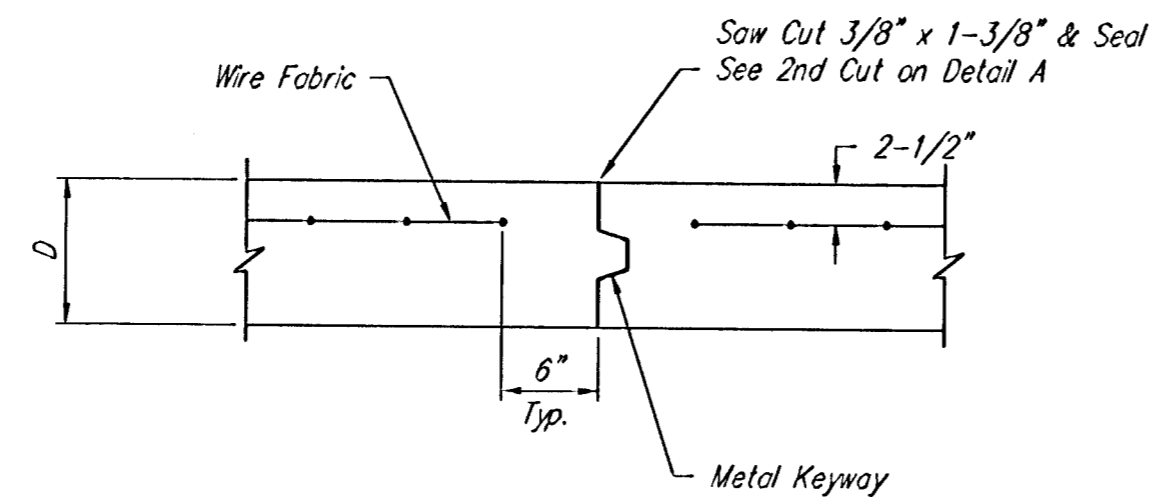

OPTIONAL CONTRACTION JOINT (CONSTRUCTION JOINT)

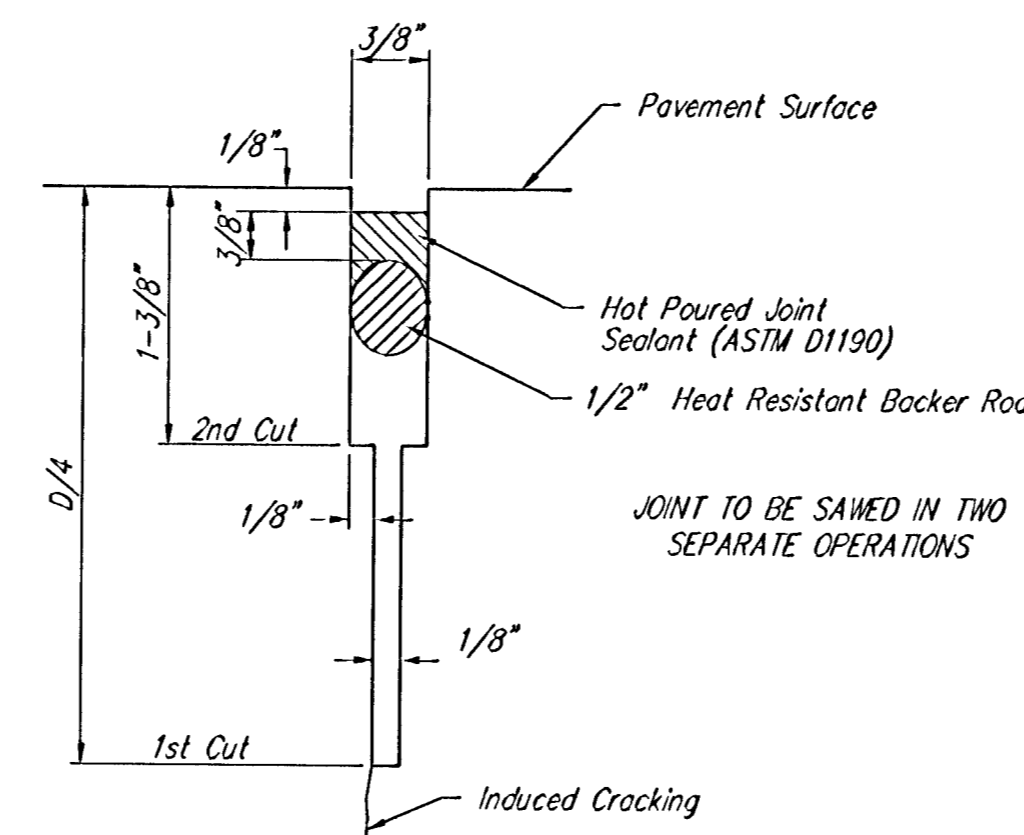

SAW JOINT DETAIL "A"

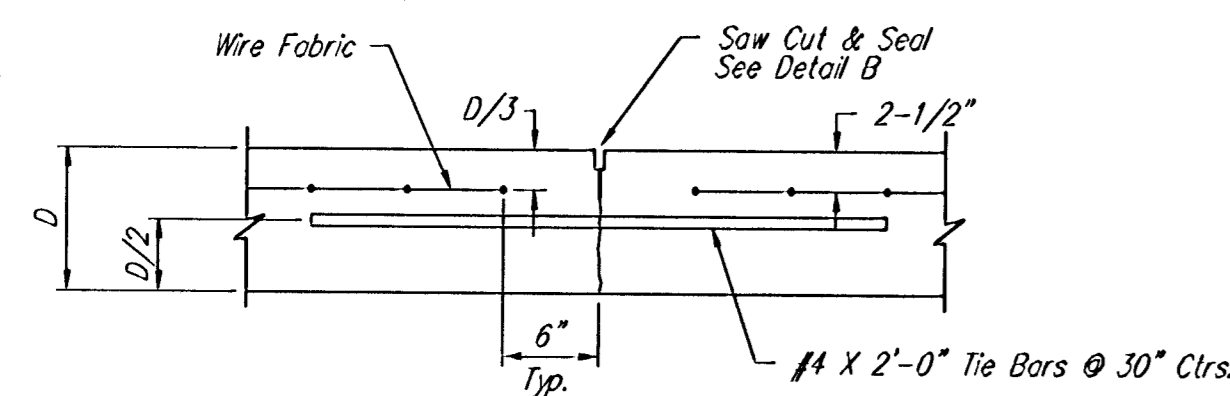

LONGITUDINAL JOINT DETAIL (L.J.)

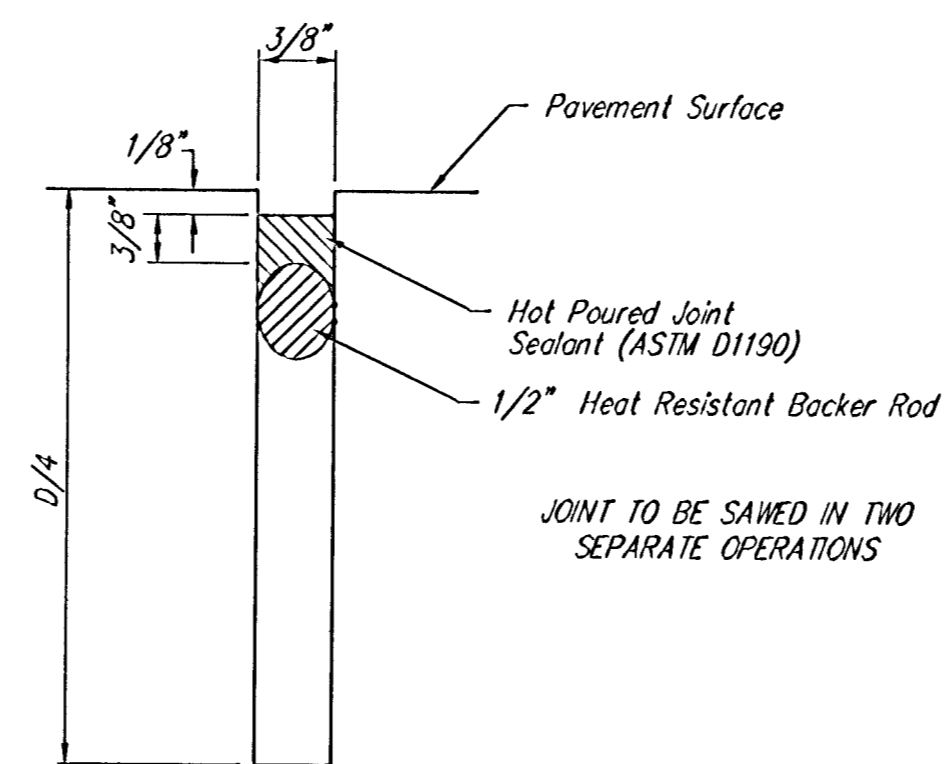

SAW JOINT DETAIL "B"

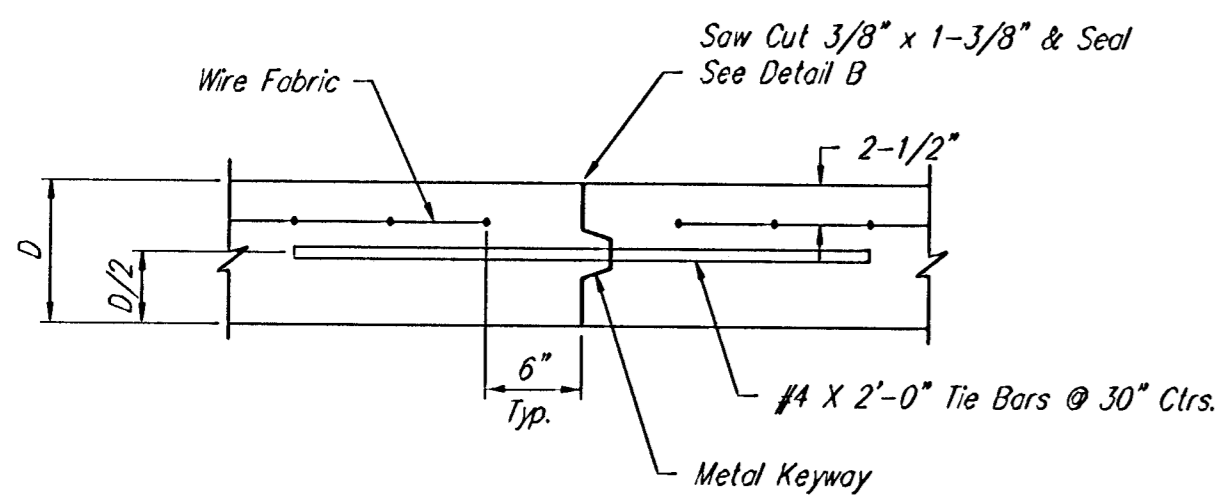

OPTIONAL LONGITUDINAL JOINT DETAIL (L.J.) (CONSTRUCTION JOINT)

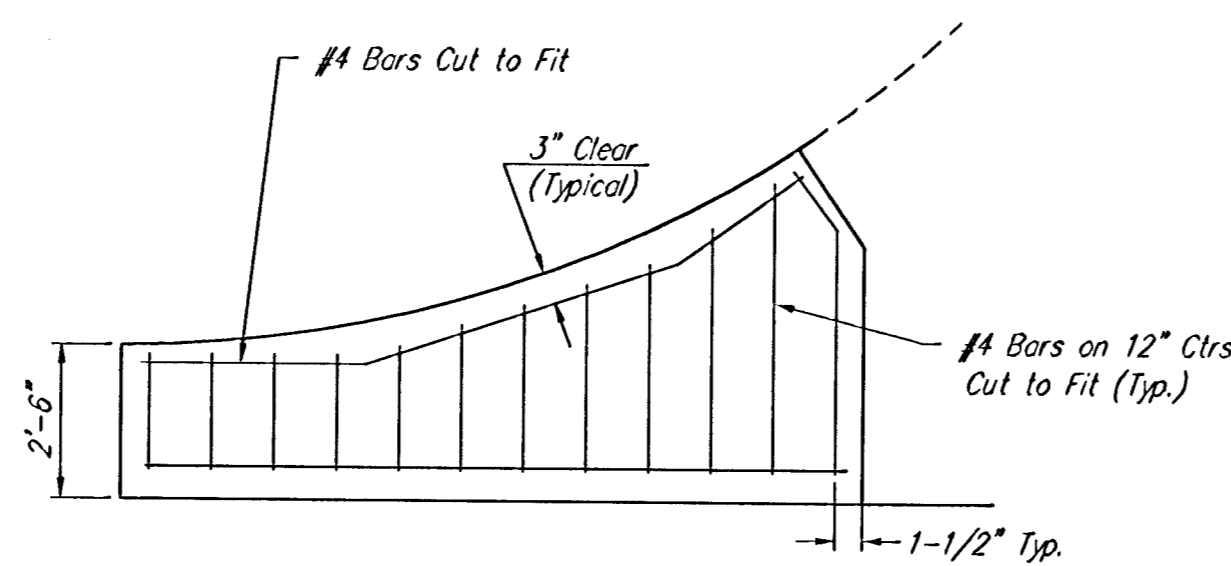

WING REINFORCING DETAIL

NOTE: 6" X 12" W4X14 Wire Fabric Reinforcing Shall Be Placed So That The Wires With The 6" Spacing Will Run Parallel With The Longitudinal Joints.

Baughman		VALLEY GUTTER DETAILS	
Baughman Company, P.A. 315 Elm St. Wichita, KS 67211 F3162637211 F3162637211 F3162637211			
PROJECT NUMBER 47283723		DESIGN STAFF	DRAWN STAFF
REVISIONS		APPROVED	DATE 08/05
		SCALE NONE	SHEET 5 OF 39
/Vgdetail			