

EXPANSION JOINT

NOTE: Extra Thickness to be Subsidiary to Price of Square Yards Pavement

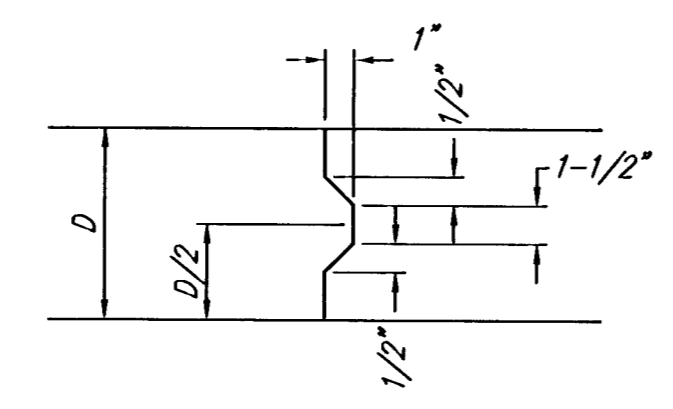

KEYWAY DETAIL

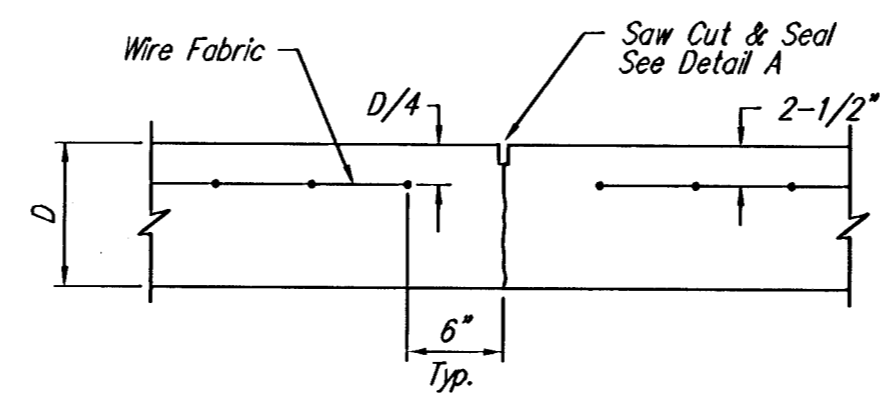

CONTRACTION JOINT DETAIL (C.J.)

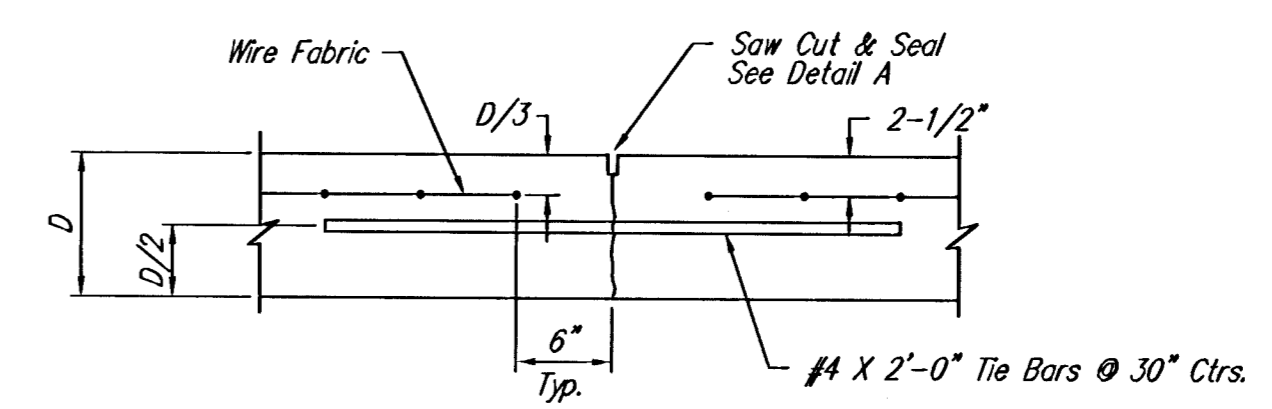

LONGITUDINAL JOINT DETAIL (L.J.)

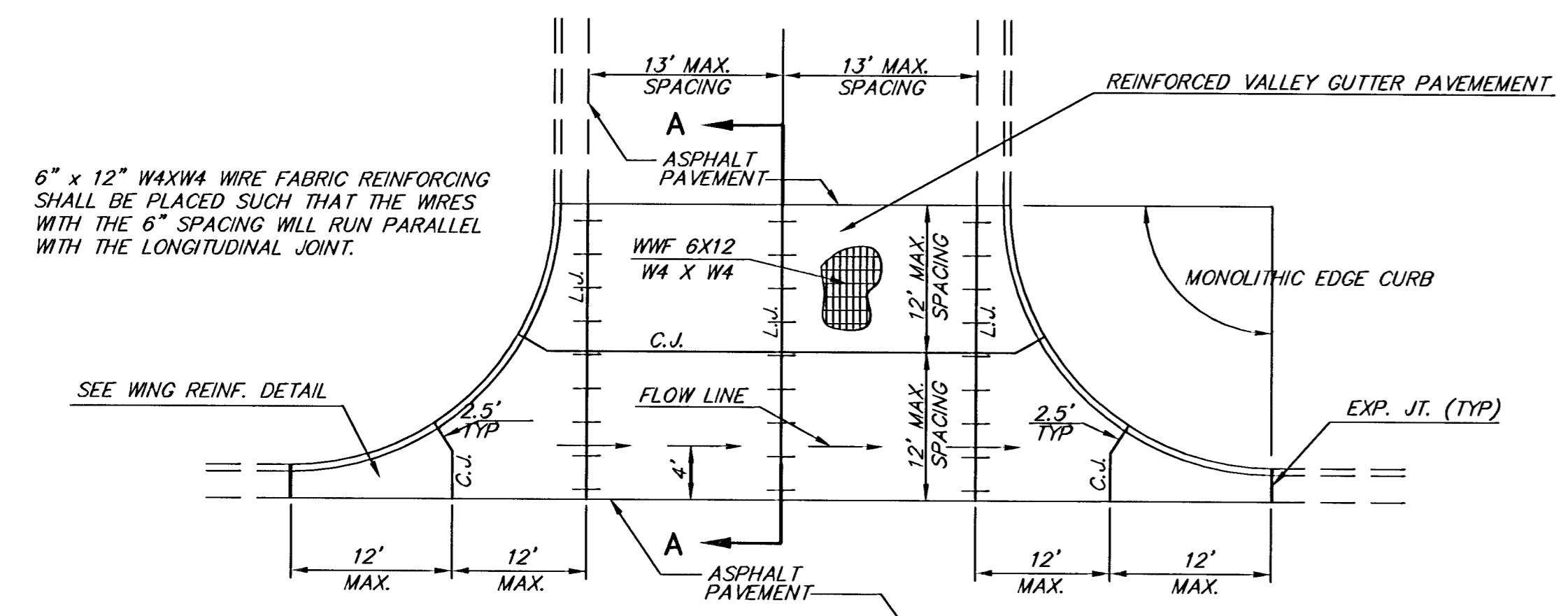

PLAN

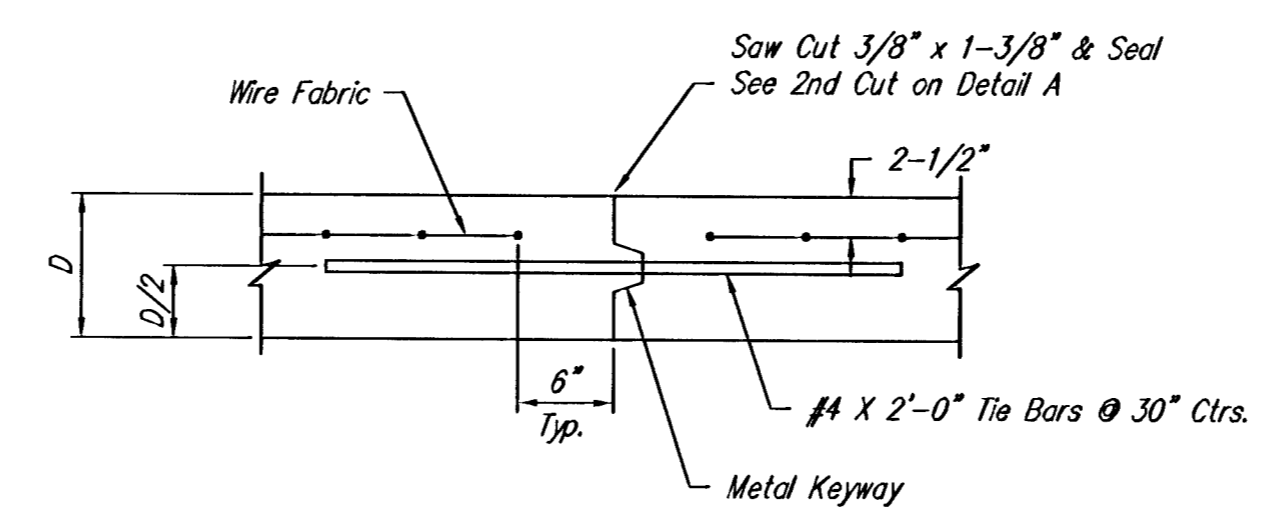

OPTIONAL LONGITUDINAL JOINT DETAIL (L.J.)

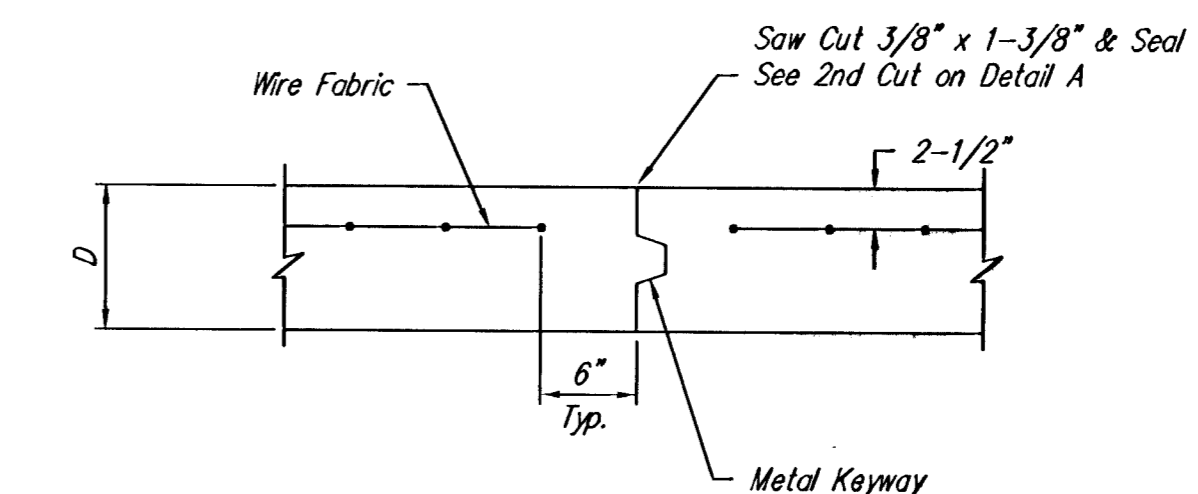

OPTIONAL CONTRACTION JOINT

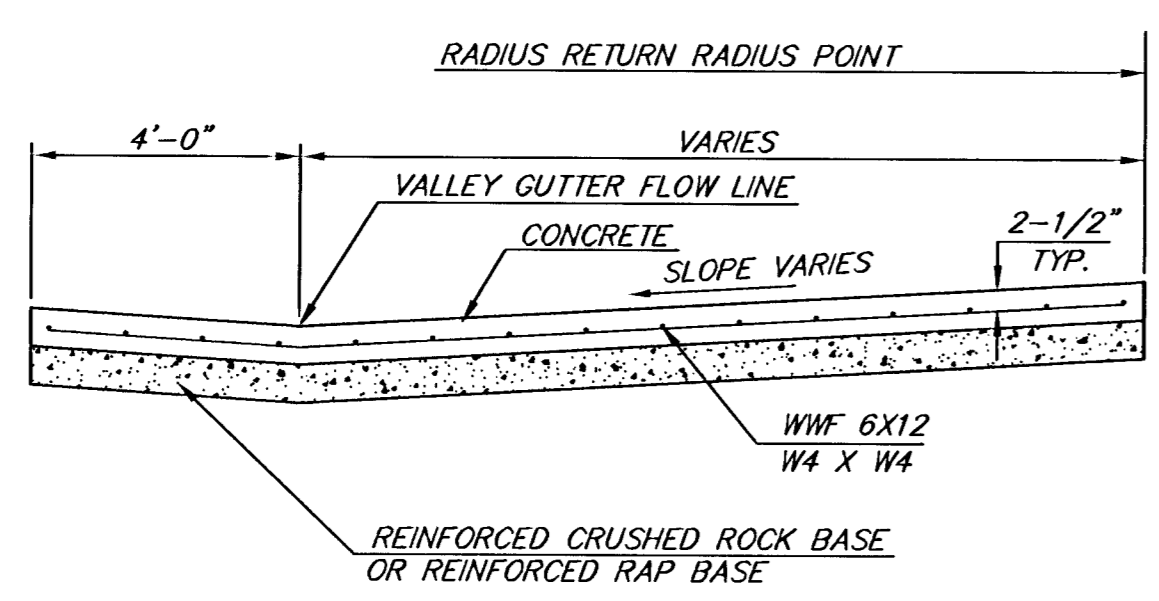

SECTION A-A

REINFORCED VALLEY GUTTER DETAIL

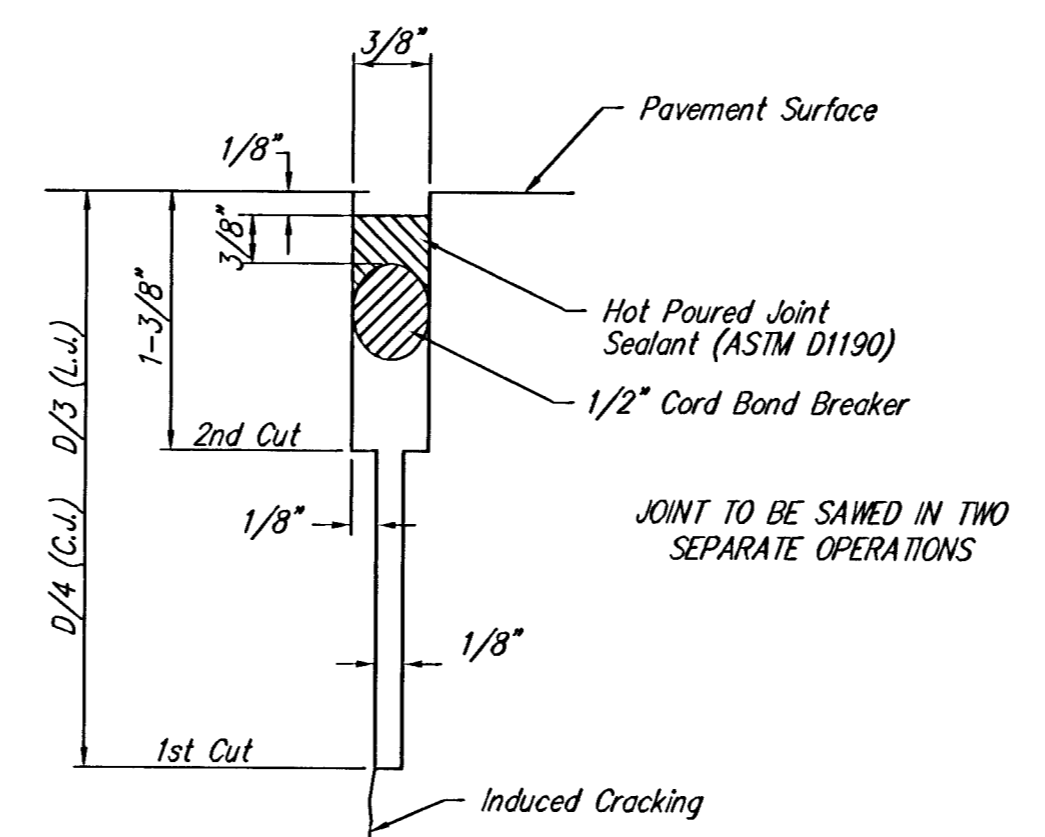

SAW JOINT DETAIL

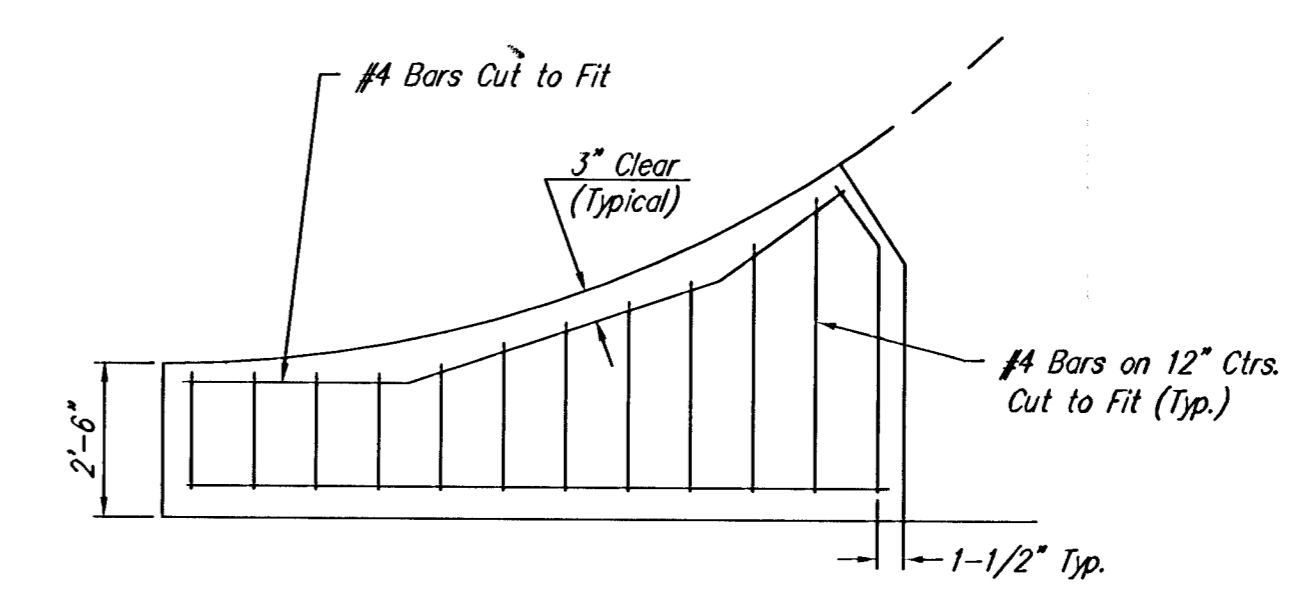

WING REINFORCING DETAIL

THE CITY OF WICHITA

CITY ENGINEER'S OFFICE  
455 NORTH MAIN STREET  
WICHITA, KANSAS 67202  
(316) 268-4601  
(316) 268-4114 FAX

VALLEY GUTTER DETAILS	
JAMES L. ARMOUR, P.E. - CITY ENGINEER	
PROJECT NUMBER 472-84214	INDEX CODE 765962
DATE OCTOBER 2005	SHEET NUMBER 4 / 29

G:\CIVIL\98118\WG\PAV\PH13 PART2\98118ED3