

PLAN	CHECKED	BY	DATE
	CHECKED		

PROFILE	CHECKED	BY	DATE
	CHECKED		

Saved: 06-08-2007 2:29:22 PM by JLN
 Plot Scale: 1/40 06-11-2007 3:12:13 PM by BEJ
 J:\SENTOU\2007\07150\2007-06-11 to City\Sanitary Sewer\DWG\08-Line02

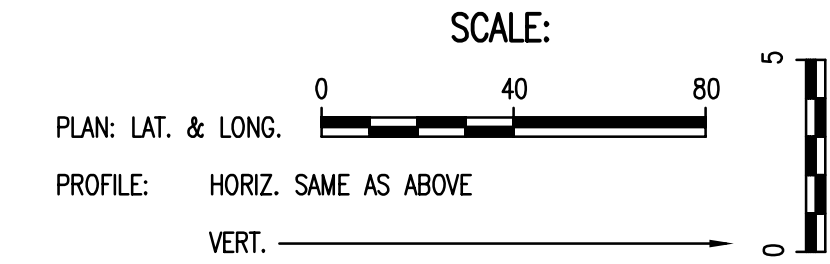
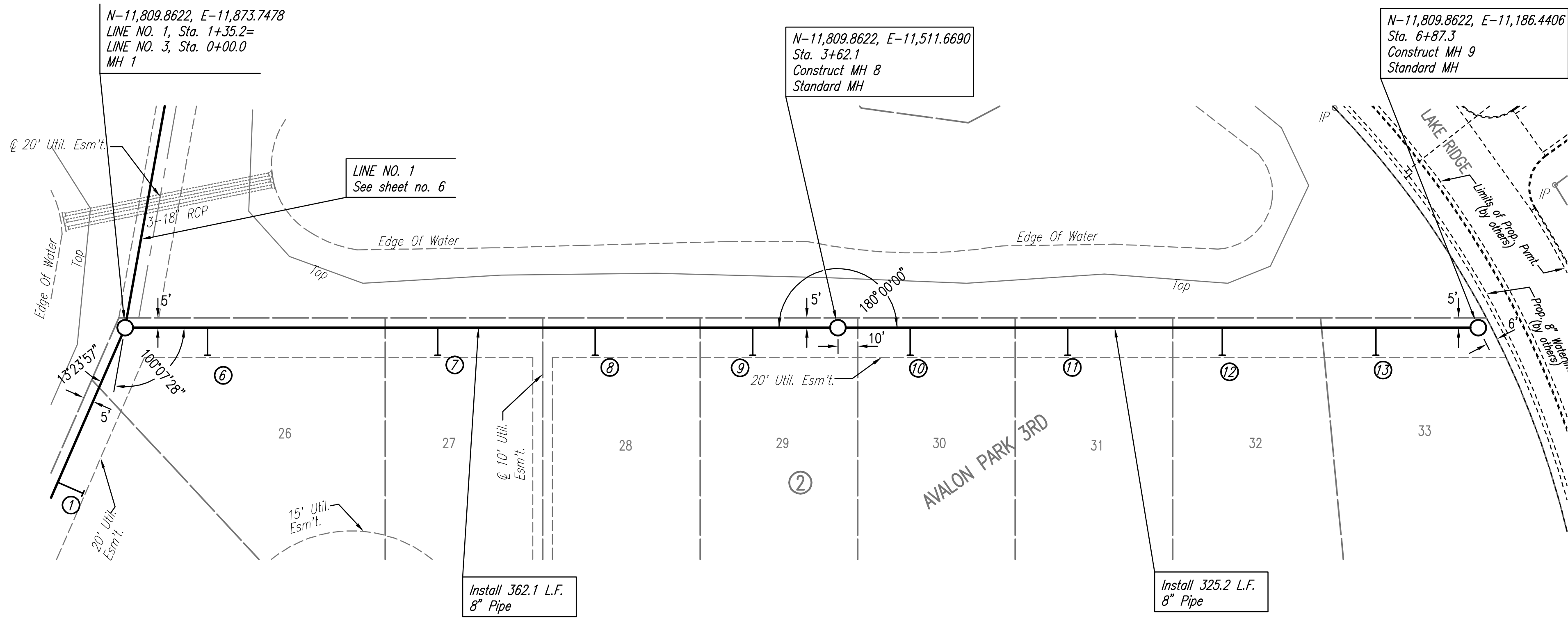

SANITARY SEWER LINE NO. 2

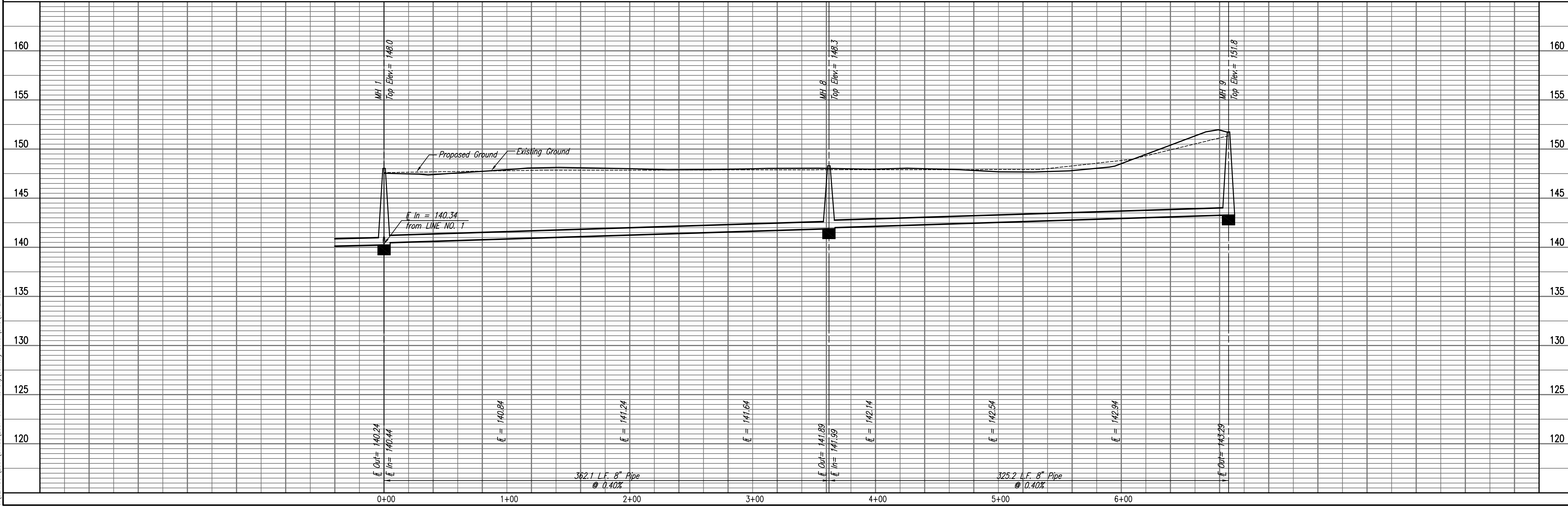

LATERAL 26, MAIN 19
 OF THE SOUTHWEST INTERCEPTOR SEWER
 SANITARY SEWER LINE NO. 2

JAMES L. ARMOUR, P.E. - CITY ENGINEER
 CITY OF WICHITA PROJECT NO. 468-84216

Professional Engineering Consultants, P.A.
 803 S. TOPERA AVENUE, SUITE 200
 WICHITA, KANSAS 67202
 316-262-2691 • FAX 316-262-3005

Job No. 35-07150-1-042
 Date APRIL 2007
 Designed By MDK
 Drawn By JAN