

GENERAL NOTES

- The construction phasing indicates major items of work and a general sequence of construction. It does not include all items of work. Certain situations may arise which preclude adhering to the original Construction Phasing. Should this occur, the Contractor may submit to the Engineer an alternate plan for approval.
- All traffic control shall conform to the latest edition of the Manual of Uniform Traffic Control Devices (MUTCD).
- Speed limit in the work zones shall remain the same prior to construction unless otherwise noted on the plans or at the discretion of the Engineer.
- All existing signs in conflict with the traffic control or the final lane configuration shall be covered or removed and either reset or stored on site for retrieval by the Owner as directed by the Engineer. Existing signs necessary for traffic during construction shall be adjusted (and later reset), as necessary, as directed by the Engineer.
- Pavement markings conflicting with the traffic control shall be either removed or covered with an approved removable tape during construction. Temporary pavement markings shall be Type I Temporary Pavement Marking Tape. The Contractor shall maintain all temporary pavement markings throughout their intended service life.
- As work is complete, the Contractor shall install permanent signing and pavement markings as in the pavement marking and signing plans or as directed by the Engineer.
- The Contractor is to build a temporary 3:1 slop along the centerline through the construction area at the end of each work day.
- The Contractor shall close sideroads as needed to complete the work necessary through the intersection. All sideroad closures shall be approved by the Engineer prior to the closure. No two consecutive sideroads shall be closed at the same time.
- The Contractor will be required to provide access to property owners or occupants during construction. The Contractor shall provide seven (7) days notice to property owners and occupants before beginning improvements in the vicinity of their property.
- The Contractor shall only close drives/entrances to businesses and residences during the time improvements are being made in the vicinity of the property.
- The Contractor shall work with adjacent businesses and residents to maintain access as long as possible in advance of the work area and restore access as soon as possible after the construction is completed in the area.
- The Contractor shall notify all property owners or business owners of any significant traffic changes during construction a minimum of seven (7) days in advance of traffic changing.
- A continuous sidewalk path for pedestrian travel along at least one (1) side of St. Francis Avenue from Waterman to Dewey must be maintained throughout construction. Signage for pedestrian traffic notifying them of sidewalk closures shall be provided as needed throughout the work zone.
- The contractor shall use High Early Strength Concrete for any concrete pavement improvements in front of all "Big Brick LLC" and "Manhattan Quads LLC" properties to minimize the duration of closure to the existing docks.
- The contractor shall coordinate with the property owners of Fisch Haus (524 S. Commerce Street, Wichita, KS 67202) to temporary relocate the wheelchair lift for the duration of the project. This shall be considered SUBSIDIARY to other items of the project. Contact Elizabeth Stevenson at (316) 200-5200 or elizabeth.janestevenson@gmail.com

Phase 1A
Phase 1A shall construct Commerce Street from 480' south of Waterman Street (the approximate center of the old Lewis Street R/W) to Waterman Street, excluding the sidewalk/pedestrian area on the east side of Commerce Street. This phase shall also construct the pedestrian crossing and the east half of St. Francis from the project beginning to the project end at Waterman Street and the storm sewer manholes west of the St. Francis & to allow for downstream drainage. Commerce Street shall be closed to thru traffic, and the sidewalk on the east side shall remain open during construction. Head to head traffic shall be maintained on the west side of St. Francis Avenue from Lewis Street to Waterman Street, and one way, southbound traffic shall be maintained the remaining south portion of St. Francis Avenue. The Contractor shall not shut down the proposed pedestrian walkway & Commerce Street at the same time to allow access to the east side of the building on 416 S St. Francis Avenue. Major items of work include but are not limited to water line installation and removal, sanitary sewer installation & removal, storm sewer installation, concrete pavement, brick paver removal & installation, curb & gutter, temporary pavement, & sidewalk.

Phase 1B
Phase 1B shall construct the west half of St. Francis from the project beginning to the project end at Waterman Street. The contractor shall maintain one way southbound traffic on the proposed southbound lane of St. Francis Avenue. Major items of work include but are not limited to water line installation and removal, storm sewer installation, concrete pavement, brick paver removal & installation, curb & gutter, temporary pavement, & sidewalk.

Phase 2A
Phase 2A shall construct the sidewalk/pedestrian area on the east side of Commerce Street from approximately 480' south of Waterman to Waterman Street. Commerce Street shall remain open to thru traffic during this phase, but the sidewalk will remain closed to pedestrian access during construction. Major items of work include sidewalk, brick pavers, landscaping, & hardscaping improvements.



Phase 2B
Phase 2B shall construct the proposed vehicle crossing and Commerce Street from the proposed vehicle crossing to the improvements completed in phase 1A excluding the concrete parking area in front of the "Big Brick LLC" properties on the east side of Commerce Street. Commerce shall be closed to thru traffic during construction. Major items of work include concrete pavement, brick paver removal & installation, water line installation & removal, and storm sewer installation.

Phase 3A
Phase 3A shall construct the south 145' of the Commerce Street improvements including the parking area & driveway east of Commerce Street. Commerce shall be closed to thru traffic during construction. Major items of work include concrete pavement, brick paver removal & installation, water line installation & removal, and storm sewer installation.

Phase 3B
Phase 3B shall construct a 40' section of Commerce Street south of Dock 4 on the east side of Commerce Street, and the remaining parking area on the east side of Commerce Street north of Dock 4. Commerce shall be closed to thru traffic during construction. The contractor shall use High Early Strength Concrete in this phase to minimize the duration of the closure to the adjacent docks. Major items of work include concrete pavement, brick paver removal & installation, water line installation & removal, and storm sewer installation.

Phase 3C
Phase 3C shall construct a 40' section Commerce Street & the parking to the east in front of Dock 4 on the east side of Commerce Street. Commerce shall be closed to thru traffic during construction. The contractor shall use High Early Strength Concrete in this phase to minimize the duration of the closure to dock 4. Major items of work include concrete pavement, brick paver removal & installation, water line installation & removal, and storm sewer installation.

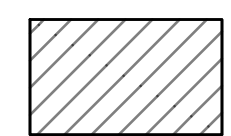
LEGEND

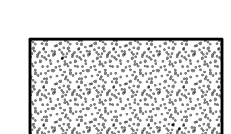
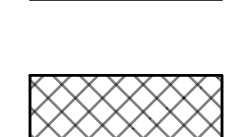
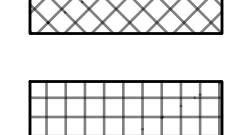
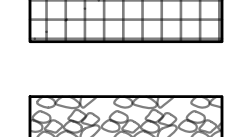
-  PHASE 1A
-  PHASE 1B
-  PHASE 2A
-  PHASE 2B
-  PHASE 3A
-  PHASE 3B
-  PHASE 3C

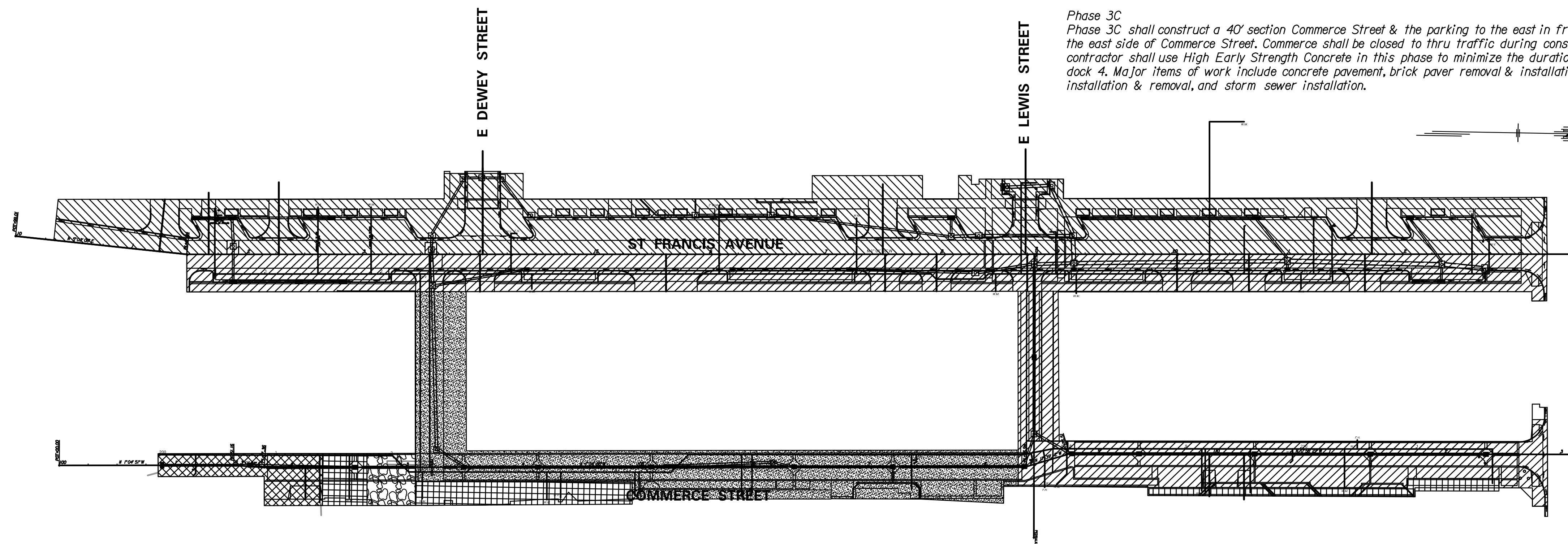

TRANSYSTEMS
245 N. WACO
SUITE 222
WICHITA, KANSAS 67202
MAIN: 316-303-3000
FAX: 316-462-5629

CONSULTANTS:

COMMERCE STREET & ST. FRANCIS AVENUE IMPROVEMENTS FROM WATERMAN TO KELLOGG
WICHITA, KANSAS
CITY OF WICHITA

REVISIONS:	DESCRIPTION	MARK	DATE

PROJ NO: 472-2021
SCALE: 1"=60'
DATE: 2/21/2024
DESIGNED BY: LCV
DRAWN BY: LCV
CHECKED BY: MDB

SHEET TITLE:
CONSTRUCTION PHASING OVERVIEW

SHEET NO.
78

d:\kranzer\2/21/2024 - 11:50:01 AM - c:\transystems\paw_bocalltransystems\paw_la_w_gkranzer\1254724C-TCP-M02-101.dgn