

Station	Elev.	Station	Elev.	Station	Elev.
0+00.0	1339.4	0+00.0	1339.4	0+00.0	1339.4
0+01.0	1339.4	0+01.0	1339.4	0+01.0	1339.4
0+02.0	1339.4	0+02.0	1339.4	0+02.0	1339.4
0+03.0	1339.4	0+03.0	1339.4	0+03.0	1339.4
0+04.0	1339.4	0+04.0	1339.4	0+04.0	1339.4
0+05.0	1339.4	0+05.0	1339.4	0+05.0	1339.4
0+06.0	1339.4	0+06.0	1339.4	0+06.0	1339.4
0+07.0	1339.4	0+07.0	1339.4	0+07.0	1339.4
0+08.0	1339.4	0+08.0	1339.4	0+08.0	1339.4
0+09.0	1339.4	0+09.0	1339.4	0+09.0	1339.4
0+10.0	1339.4	0+10.0	1339.4	0+10.0	1339.4
0+11.0	1339.4	0+11.0	1339.4	0+11.0	1339.4
0+12.0	1339.4	0+12.0	1339.4	0+12.0	1339.4
0+13.0	1339.4	0+13.0	1339.4	0+13.0	1339.4
0+14.0	1339.4	0+14.0	1339.4	0+14.0	1339.4
0+15.0	1339.4	0+15.0	1339.4	0+15.0	1339.4
0+16.0	1339.4	0+16.0	1339.4	0+16.0	1339.4
0+17.0	1339.4	0+17.0	1339.4	0+17.0	1339.4
0+18.0	1339.4	0+18.0	1339.4	0+18.0	1339.4
0+19.0	1339.4	0+19.0	1339.4	0+19.0	1339.4
0+20.0	1339.4	0+20.0	1339.4	0+20.0	1339.4
0+21.0	1339.4	0+21.0	1339.4	0+21.0	1339.4
0+22.0	1339.4	0+22.0	1339.4	0+22.0	1339.4
0+23.0	1339.4	0+23.0	1339.4	0+23.0	1339.4
0+24.0	1339.4	0+24.0	1339.4	0+24.0	1339.4
0+25.0	1339.4	0+25.0	1339.4	0+25.0	1339.4
0+26.0	1339.4	0+26.0	1339.4	0+26.0	1339.4
0+27.0	1339.4	0+27.0	1339.4	0+27.0	1339.4
0+28.0	1339.4	0+28.0	1339.4	0+28.0	1339.4
0+29.0	1339.4	0+29.0	1339.4	0+29.0	1339.4
0+30.0	1339.4	0+30.0	1339.4	0+30.0	1339.4
0+31.0	1339.4	0+31.0	1339.4	0+31.0	1339.4
0+32.0	1339.4	0+32.0	1339.4	0+32.0	1339.4
0+33.0	1339.4	0+33.0	1339.4	0+33.0	1339.4
0+34.0	1339.4	0+34.0	1339.4	0+34.0	1339.4
0+35.0	1339.4	0+35.0	1339.4	0+35.0	1339.4
0+36.0	1339.4	0+36.0	1339.4	0+36.0	1339.4
0+37.0	1339.4	0+37.0	1339.4	0+37.0	1339.4
0+38.0	1339.4	0+38.0	1339.4	0+38.0	1339.4
0+39.0	1339.4	0+39.0	1339.4	0+39.0	1339.4
0+40.0	1339.4	0+40.0	1339.4	0+40.0	1339.4
0+41.0	1339.4	0+41.0	1339.4	0+41.0	1339.4
0+42.0	1339.4	0+42.0	1339.4	0+42.0	1339.4
0+43.0	1339.4	0+43.0	1339.4	0+43.0	1339.4
0+44.0	1339.4	0+44.0	1339.4	0+44.0	1339.4
0+45.0	1339.4	0+45.0	1339.4	0+45.0	1339.4
0+46.0	1339.4	0+46.0	1339.4	0+46.0	1339.4
0+47.0	1339.4	0+47.0	1339.4	0+47.0	1339.4
0+48.0	1339.4	0+48.0	1339.4	0+48.0	1339.4
0+49.0	1339.4	0+49.0	1339.4	0+49.0	1339.4
0+50.0	1339.4	0+50.0	1339.4	0+50.0	1339.4

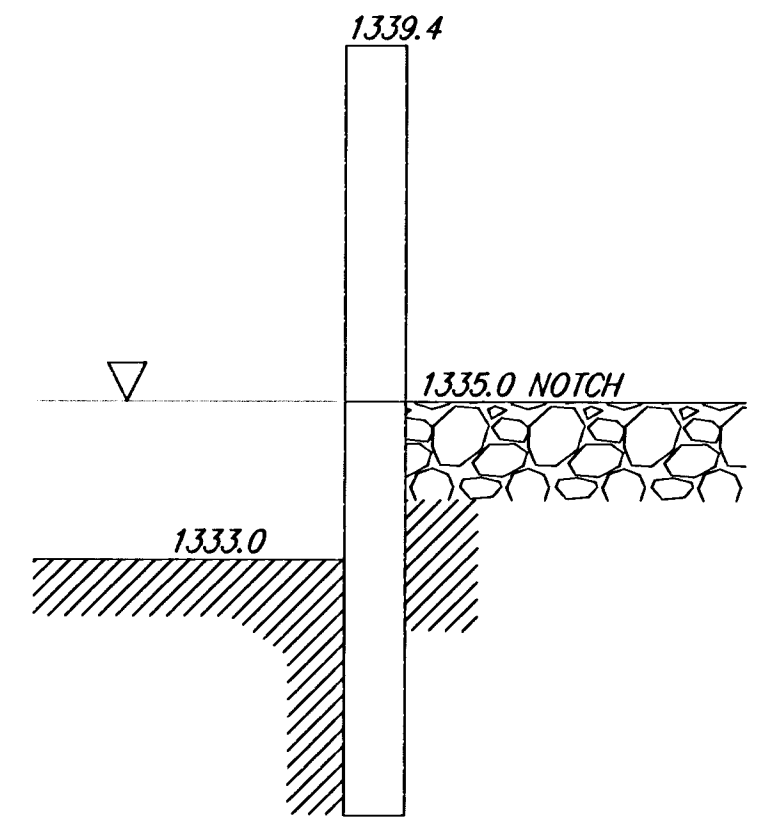

Pond Coordinates

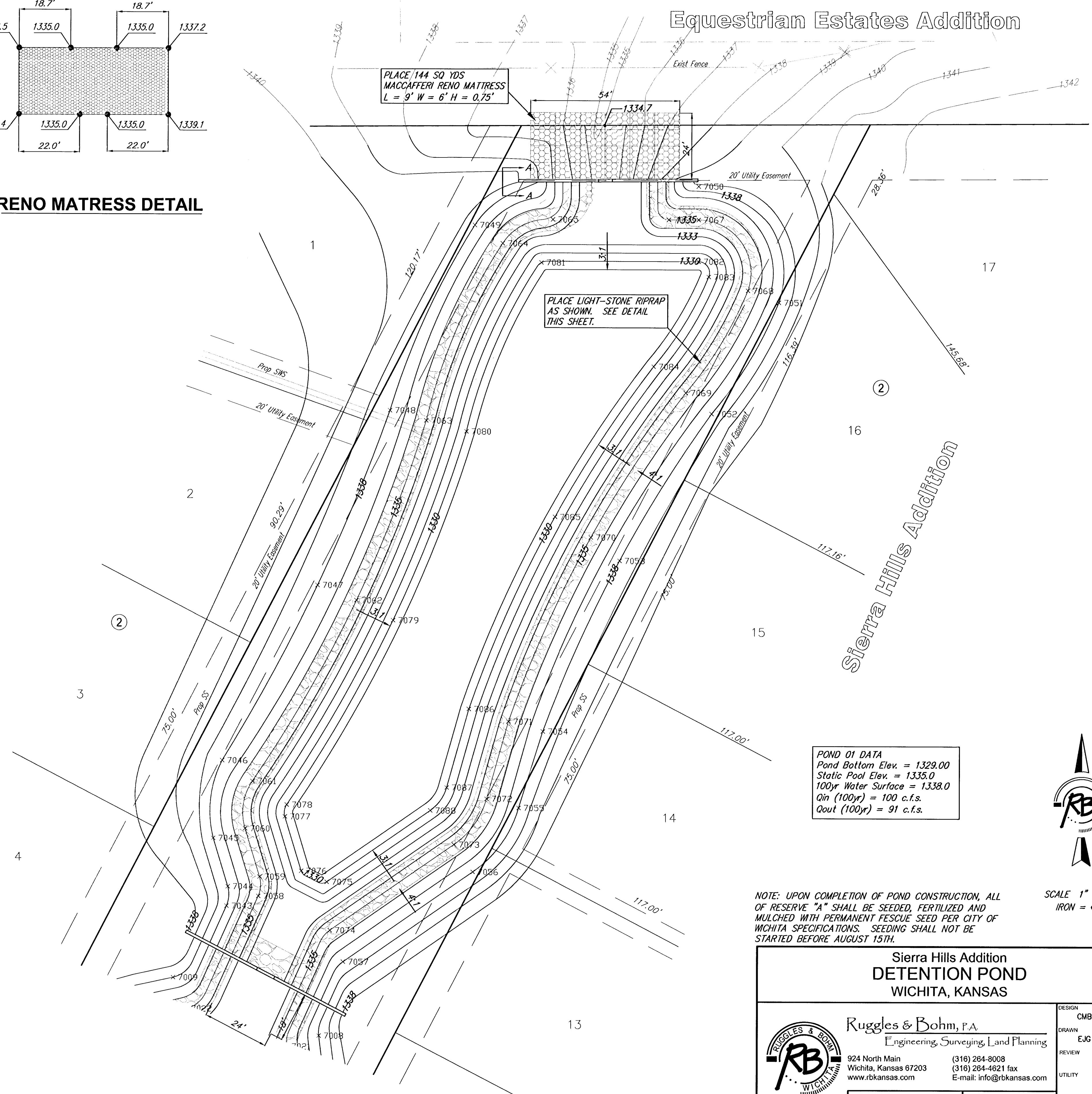
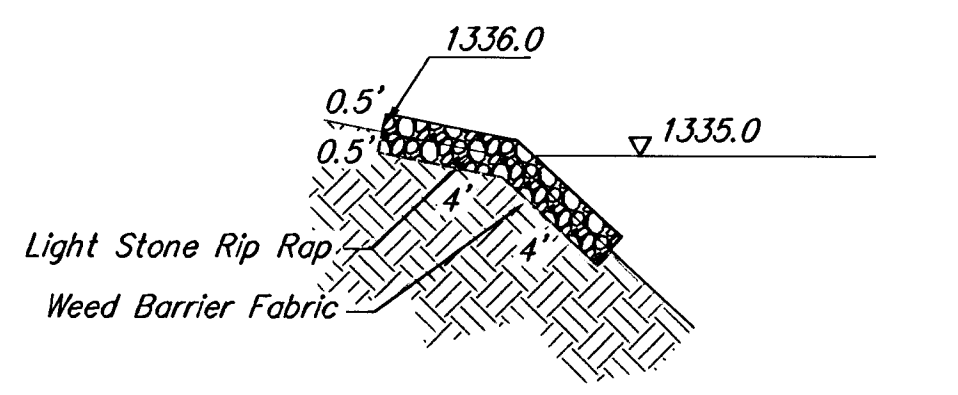

POND 01 DATA
 Pond Bottom Elev. = 1329.00
 Static Pool Elev. = 1335.0
 100yr Water Surface = 1338.0
 Qin (100yr) = 100 c.f.s.
 Qout (100yr) = 91 c.f.s.



NOTE: UPON COMPLETION OF POND CONSTRUCTION, ALL OF RESERVE "A" SHALL BE SEED, FERTILIZED AND MULCHED WITH PERMANENT FESCUE SEED PER CITY OF WICHITA SPECIFICATIONS. SEEDING SHALL NOT BE STARTED BEFORE AUGUST 15TH.

**Sierra Hills Addition
DETENTION POND
WICHITA, KANSAS**

Ruggles & Bohm, P.A.
Engineering, Surveying, Land Planning

924 North Main (316) 284-8008
Wichita, Kansas 67203 (316) 284-4621 fax
www.rbkansas.com E-mail: info@rbkansas.com

DESIGN	CMB	SHEET 37 OF 69
DRAWN	EJG	
REVIEW		
UTILITY		
DRAWING FILE	pond {Pond Plan}	PROJECT NUMBER 472-83703
DATE	Apr. 22, 2003	