

EXPANSION JOINT

NOTE: Extra Thickness to be Subsidiary to Price of Square Yards Pavement

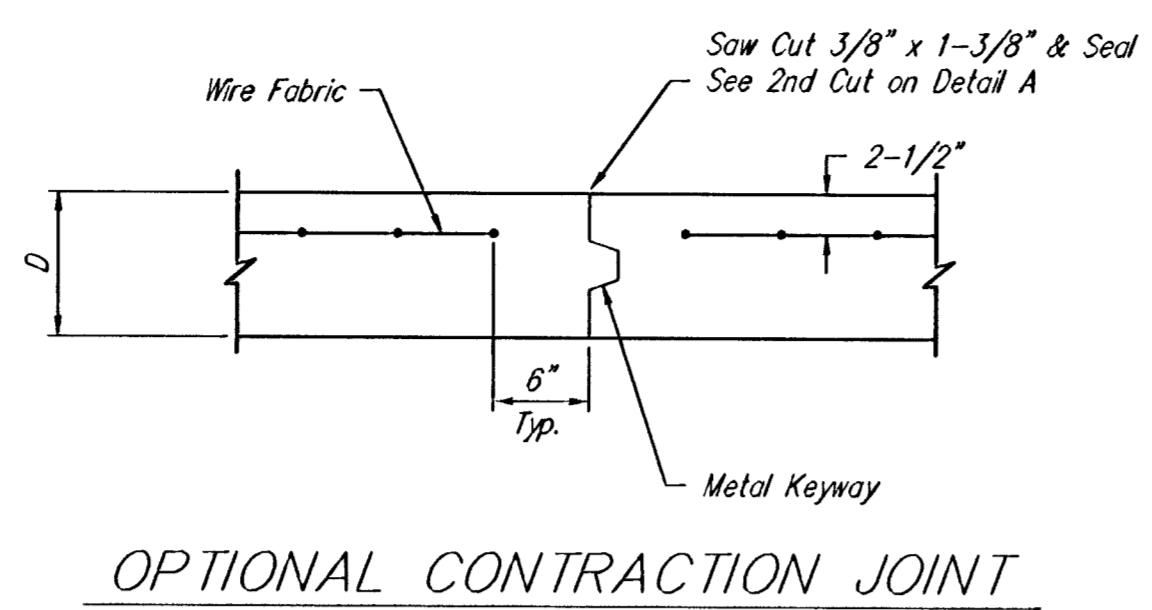

OPTIONAL CONTRACTION JOINT

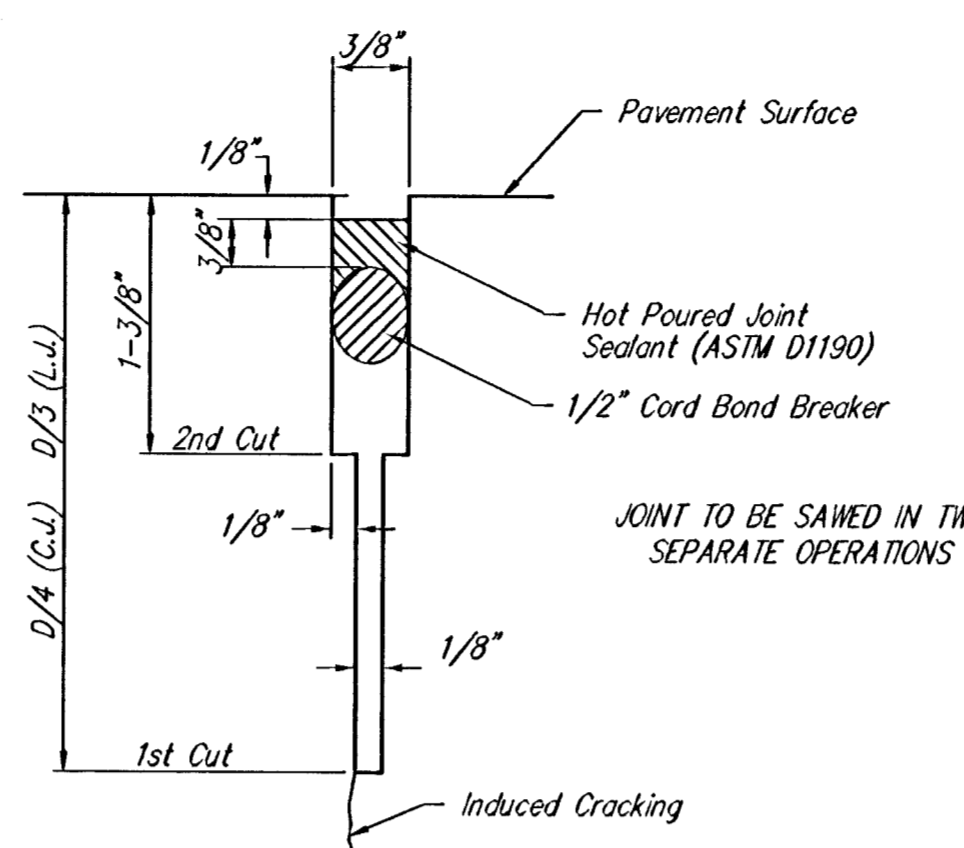

SAW JOINT DETAIL

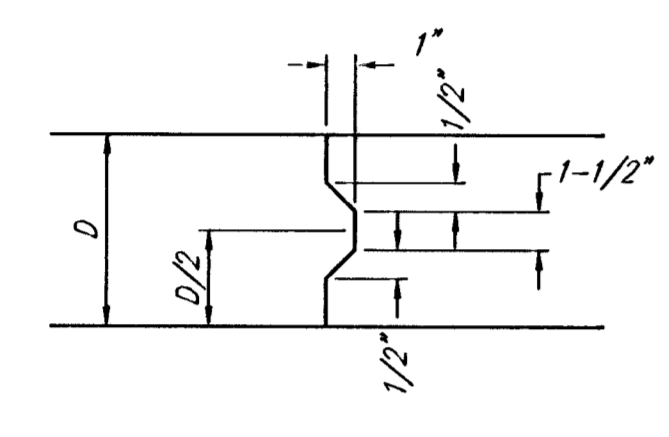

KEYWAY DETAIL

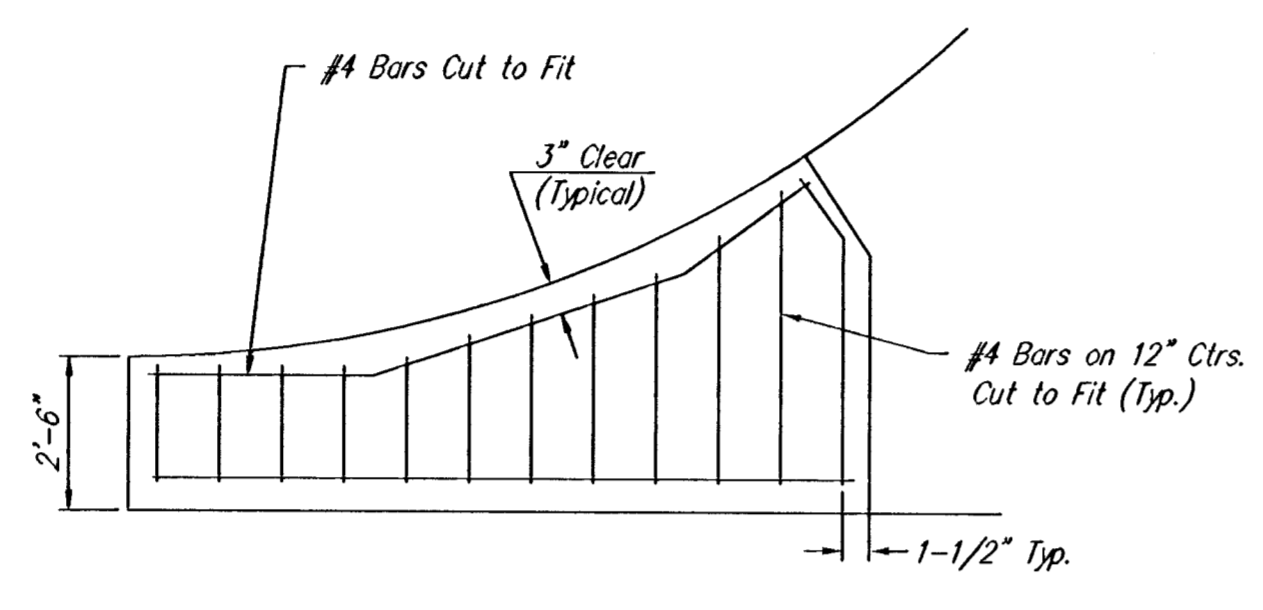

WING REINFORCING DETAIL

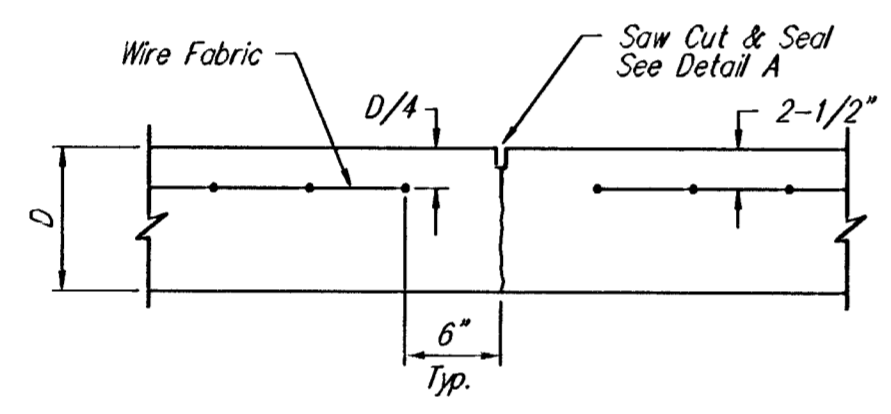

CONTRACTION JOINT DETAIL (C.J.)

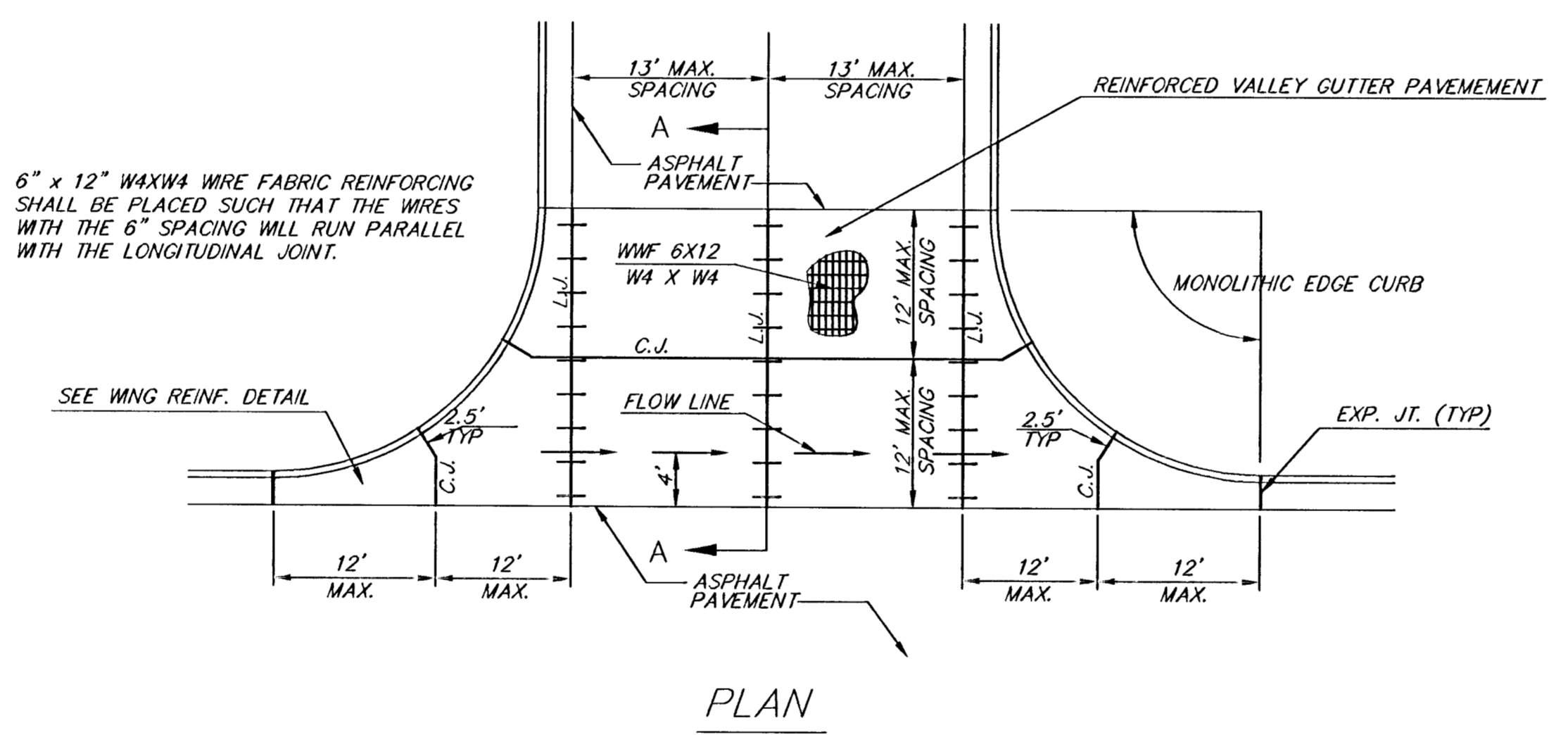

PLAN

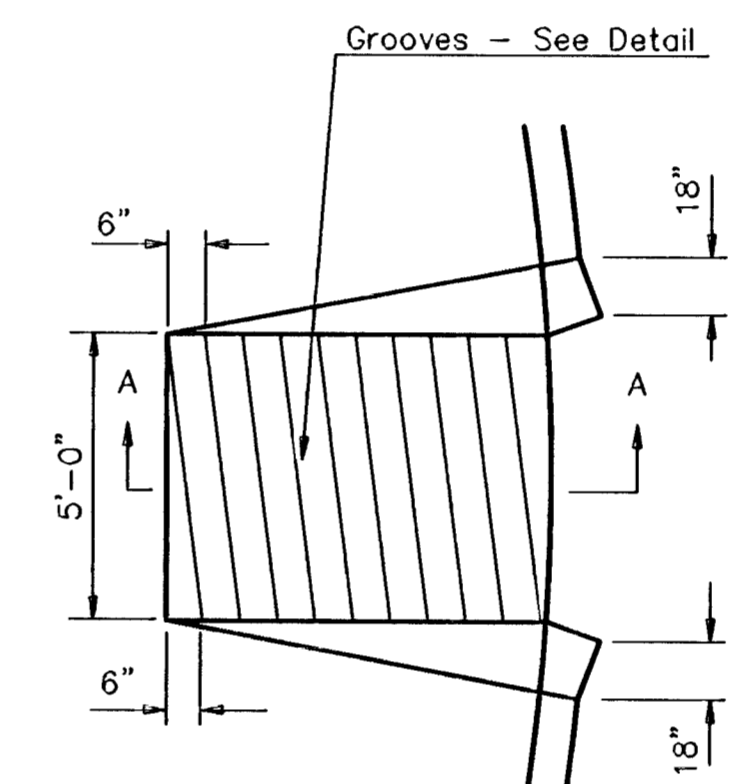

WHEELCHAIR RAMP PLAN VIEW

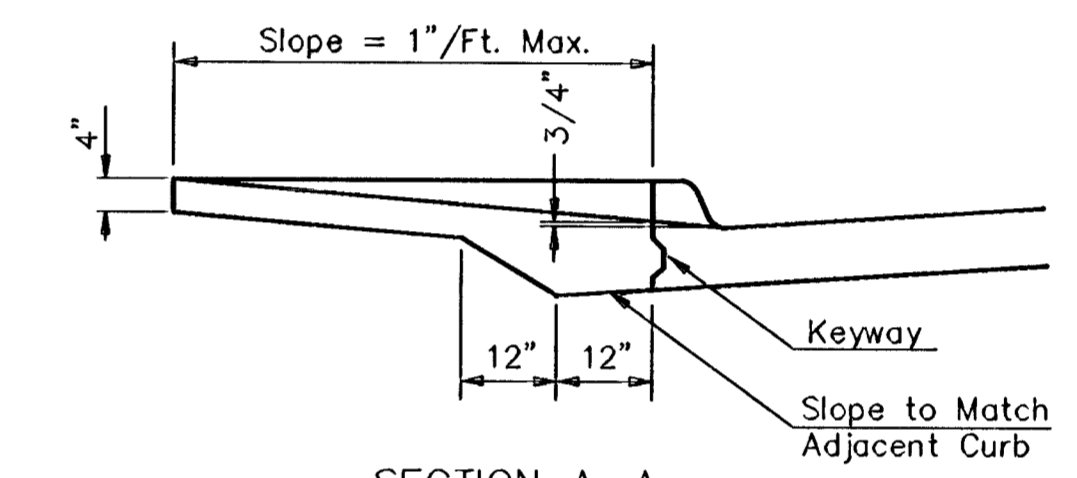

SECTION A-A

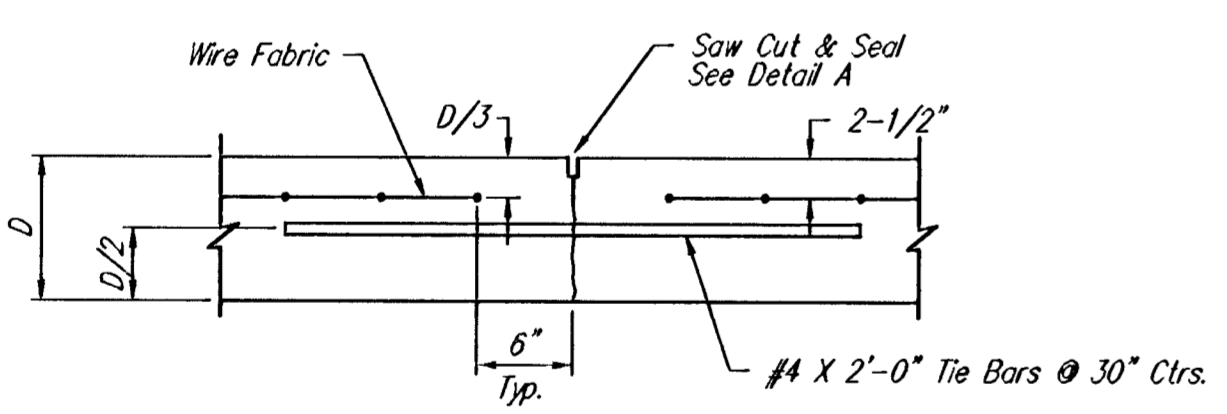

LONGITUDINAL JOINT DETAIL (L.J.)

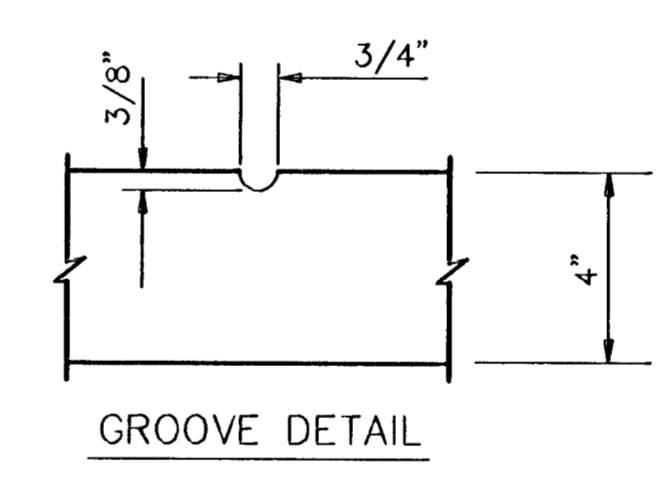

GROOVE DETAIL

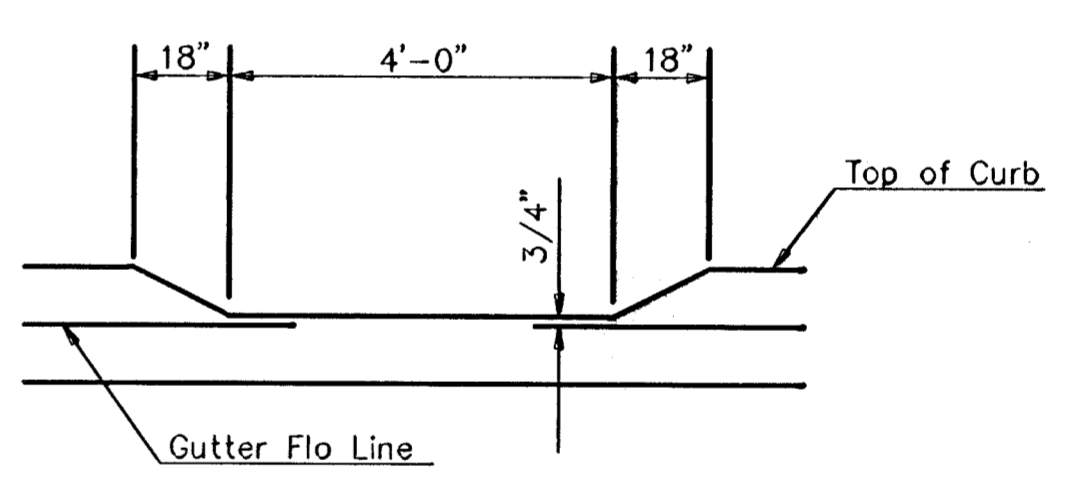

DEPRESSED CURB DETAIL

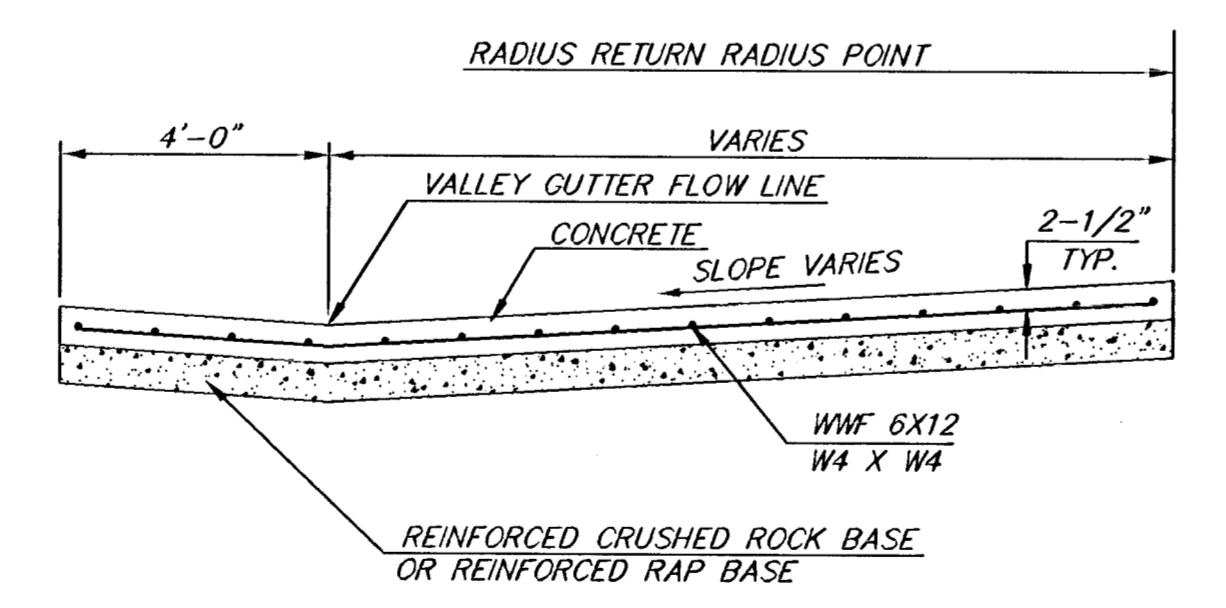

SECTION A-A

REINFORCED VALLEY GUTTER DETAIL

WHEELCHAIR RAMP DETAIL

OPTIONAL LONGITUDINAL JOINT DETAIL (L.J.)

<p>THE CITY OF WICHITA</p> <p>CITY ENGINEER'S OFFICE 455 NORTH MAIN STREET WICHITA, KANSAS 67202 (316) 268-4501 (316) 268-4114 FAX</p>	VALLEY GUTTER DETAILS	
	WHEELCHAIR RAMP DETAILS	
	M. E. LINDEBAK P.E. - CITY ENGINEER	
	PROJECT NUMBER 472-83449	INDEX CODE 765711
DATE MAR 96	SHEET 3 OF 20	

H:\CIVIL\101077\DWG\PAV\01077ED2.DWG Tue Mar 05 15:48:20 2002