

VACATION HEARING

RECOMMENDATION FROM MAPC TO BOARD OF CITY COMMISSIONERS

V-1334 VACATION OF STREET RIGHT-OF-WAY GENERALLY LOCATED ON THE WEST SIDE OF ZOO BOULEVARD IN AN AREA SOUTH OF THE WEST STREET/ZOO BOULEVARD INTERSECTION.

NOTE: The City Clerk will certify as to proper publication of notice of hearing and filing of written protest.

A petition for the above identified vacation request has been filed in the office of the City Clerk. The Planning Commission recommends that the Board of City Commissioners find that no private rights will be injured or endangered and the public will suffer no loss or inconvenience by granting by order the vacation request subject to:

- A. Proper publication of notice of public hearing.
- B. The absence of proper written protest filed with the City Clerk.
- C. All proceedings being without cost to the City, County, or any utility company.
- D. Any relocation or reconstruction of utilities necessitated by this vacation shall be at the sole expense of the applicant.
- E. The vacation order shall retain the street right-of-way being vacated as a utility easement.

Bayouth moved, Goebel seconded and it carried unanimously. Chisholm and Moore were absent. Gardner and Hansen not yet present. (7/11/85)

ACTION: Close the public hearing, approve the vacation request, authorize the Mayor to sign the vacation order and instruct the City Clerk to file a certified copy of the order with the Sedgwick County Register of Deeds.

VACATION CASE DATA

Legal Description: That part of 10th Street as platted in "Golden Gardens," an Addition to Wichita, Sedgwick County, Kansas, described as beginning at a point in the north line and 152.0' east of the northwest corner of Block 5 in said Addition, said point being 192.0' east of the centerline of West Street as platted in said Addition; thence north parallel with the centerline of West Street, a distance of 60.0' to a point in the north line of 10th Street; thence east along the north line of 10th Street, a distance of 12.10' to a point in the westerly line of Bickel Street, now Zoo Boulevard; thence southeasterly along the westerly line of Zoo Boulevard, 76.74' to a point in the south line of 10th Street; thence west 61.2' to the point of beginning. (MAPC NO. V-1334)

Applicant: Mr. Malcolm Atkinson
3901 Zoo Boulevard
Wichita, Kansas 67212

Protestors: None before the Subdivision Committee or MAPC.

BEFORE THE BOARD OF CITY COMMISSIONERS
OF THE CITY OF WICHITA, SEDGWICK COUNTY, KANSAS

IN THE MATTER OF THE VACATION OF)
STREET RIGHT OF WAY)
)
GENERALLY LOCATED ON THE WEST SIDE)
OF ZOO BOULEVARD IN AN AREA SOUTH)
OF THE WEST STREET/ZOO BOULEVARD)
INTERSECTION)
)
MORE FULLY DESCRIBED BELOW)

MICROFILMED
OF RECORD

Approved by Board of Commissioners
AUG 07 1985
SEDGWICK COUNTY KANSAS } ss
FILED FOR RECORD AT
8:00 AM

VACATION ORDER

Ed Peral
Deputy

AUG 15 1985
NO. 7 61818
PAT KETTLER
REGISTER OF DEEDS

NOW on this 6th day of August, 1985, comes on for hearing the petition for vacation filed by Mr. Malcolm Atkinson, praying for the vacation of the following described street right of way, to-wit:

That part of 10th Street as platted in "Golden Gardens," an Addition to Wichita, Sedgwick County, Kansas, described as beginning at a point in the north line and 152.0' east of the northwest corner of Block 5 in said Addition, said point being 192.0' east of the centerline of West Street as platted in said Addition; thence north parallel with the centerline of West Street, a distance of 60.0' to a point in the north line of 10th Street; thence east along the north line of 10th Street, a distance of 12.10' to a point in the westerly line of Bickel Street, now Zoo Boulevard; thence southeasterly along the westerly line of Zoo Boulevard, 76.74' to a point in the south line of 10th Street; thence west 61.2' to the point of beginning. (MAPC NO. V-1334)

The City Commission, after being duly and fully informed as to fully understand the true nature of this petition and the propriety of granting the same, makes the following findings:

1. That due and legal notice has been given by publication as required by law, by publication in the Daily Record of notice of this vacation proceeding for consecutive weeks on July 30, Aug 5, 1985.
2. No private rights will be injured or endangered by the vacation of the above-described street right of way, and the public will suffer no loss or inconvenience thereby.
3. In justice to the petitioner the prayer of the petition ought to be granted.
4. No written objection to said vacation has been filed with the City Clerk by any owner or adjoining owner who would be a proper party to the petition.
5. The vacation order shall retain the street right of way being vacated as a utility easement.
6. The vacation of the street right of way described herein should be approved.

IT IS, THEREFORE, BY THE BOARD OF CITY COMMISSIONERS, on this 6th day of August, 1985, ordered that the above-described street right of way is hereby vacated. IT IS FURTHER ORDERED that the street right of way being vacated is hereby retained as a utility easement. IT IS FURTHER ORDERED that the City Clerk shall certify a copy of this order to the Register of Deeds of Sedgwick County.

R. C. Brown
R. C. Brown, Mayor

ATTEST:
Donald C. Gisick
Donald C. Gisick, City Clerk

Approved as to Form:
John Dekker
John Dekker, Director of Law

city clerk

5.00

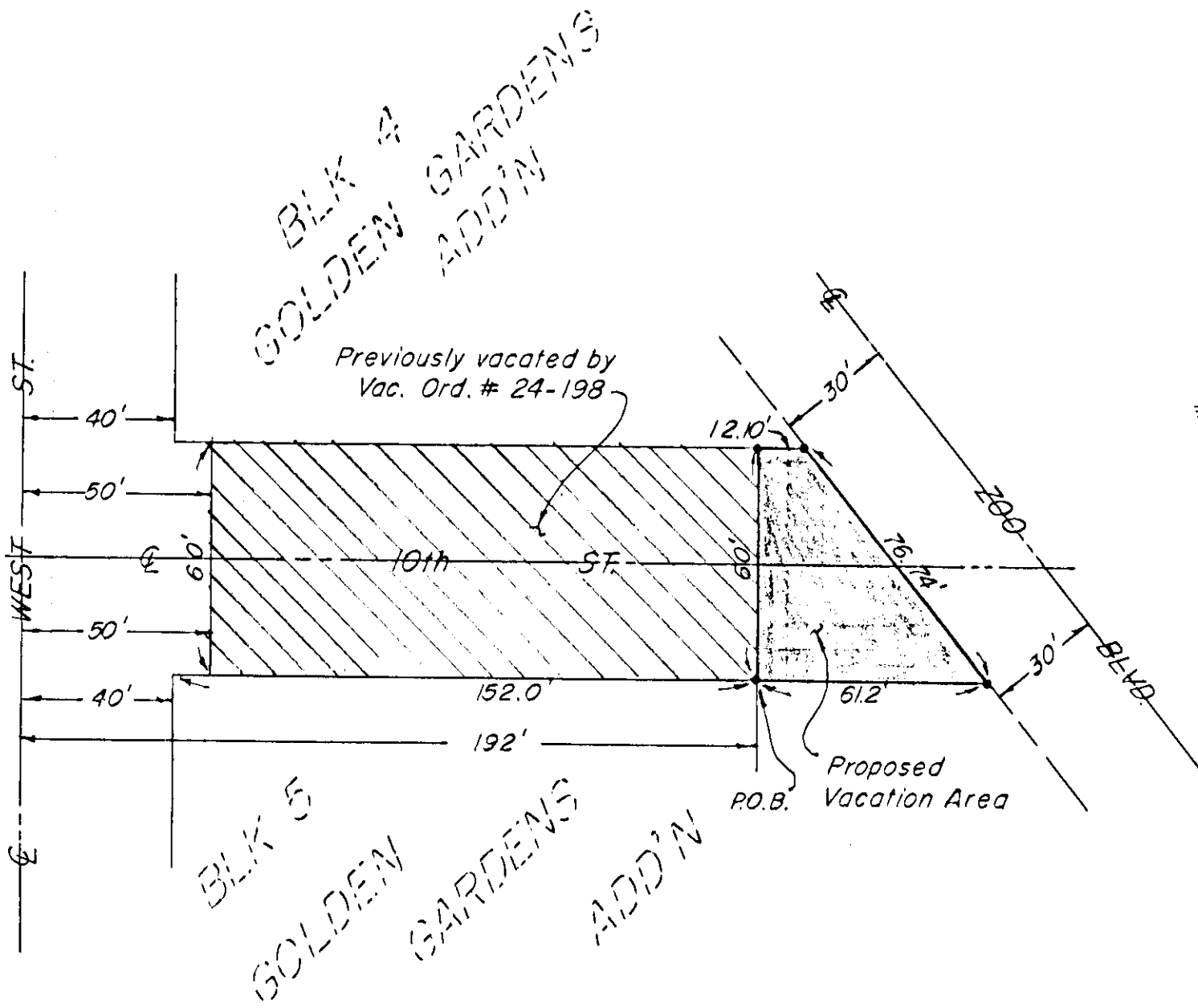

1" = 40'
 • = Iron
 #85-058-S

