

LAURA

From 30' S. of N:L. Lot 13 River Side Gardens TO S:L. Mac Arthur Rd.

472-76-245-80664-000-001

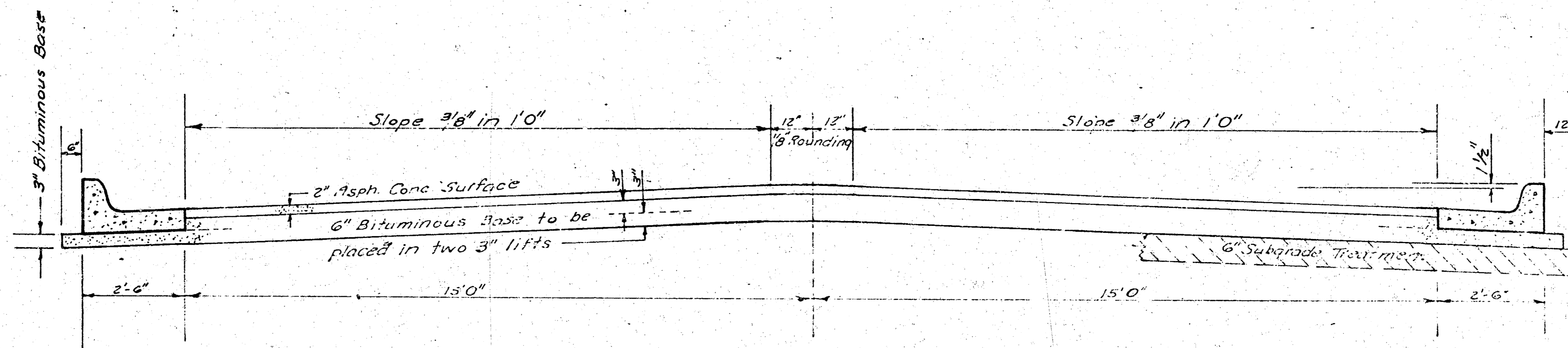

TYPICAL SECTION

35' ASPHALTIC CONCRETE PAVEMENT WITH BITUMINOUS BASE

A TACK COAT OF EMULSIFIED ASPHALT (SS-1H) SHALL BE APPLIED AT AN APPROXIMATE RATE 0.05 GALLONS PER SQ YD BETWEEN LIFTS OF ASPHALTIC MATERIALS WHEN ORDERED BY THE ENGINEER. TACK COAT WILL NOT BE PAID FOR DIRECTLY AND SHALL BE CONSIDERED AS SUBSIDIARY TO PRICE BID FOR ASPHALTIC PAVEMENT.

BITUMINOUS BASE AND ASPHALTIC CONCRETE WEARING SURFACE SHALL BE PLACED WITH A LAYDOWN MACHINE HAVING AUTOMATIC CONTROLS FOR CROWN AND GRADE. CONSTRUCTION JOINTS IN EACH LIFT SHALL BE STAGGERED A MINIMUM DISTANCE OF 1' WITH JOINTS IN PRECEDING LIFTS AND PLACED SUCH THAT A JOINT WILL BE CONSTRUCTED ON THE CENTERLINE IN THE TOP LIFT.

*The A.C. Pavement between the comb curb & gutter shall be paid as 2 1/2" A.C. Pavement (6" Bituminous Base).
The Bituminous Base under the comb curb & gutter shall be paid as Sq.Yds. 3" Bituminous Base.*

COMBINED CURB & GUTTER

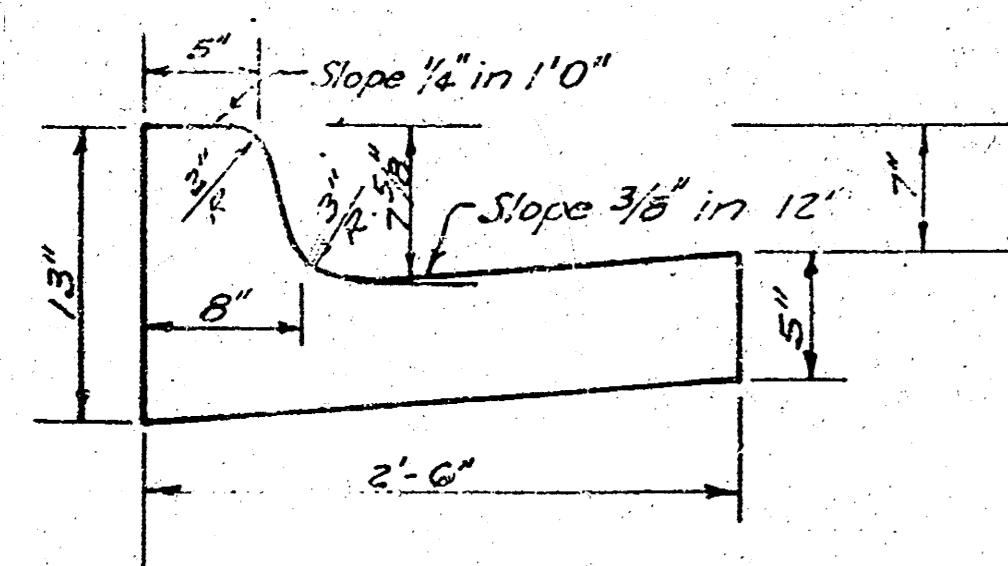

ROLL TYPE CURB & GUTTER

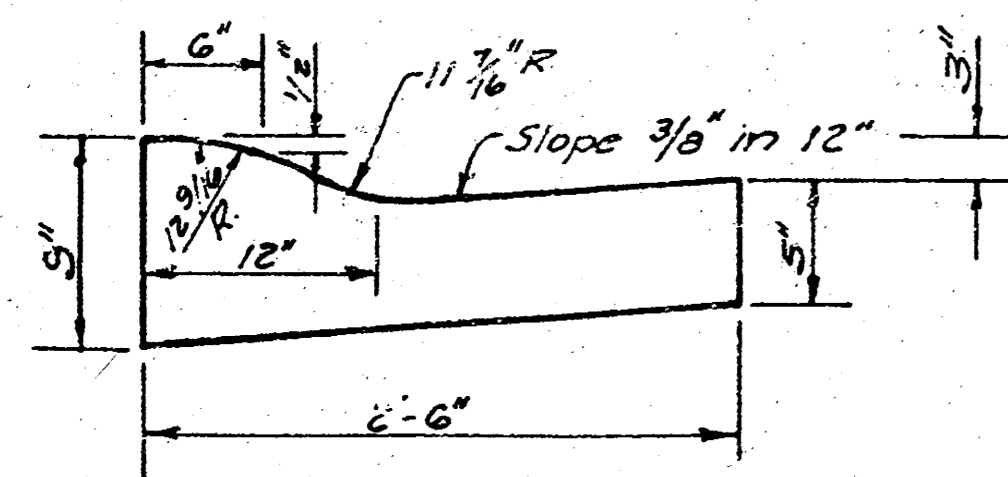

DETAIL OF TRANSVERSE CONSTRUCTION JOINTS

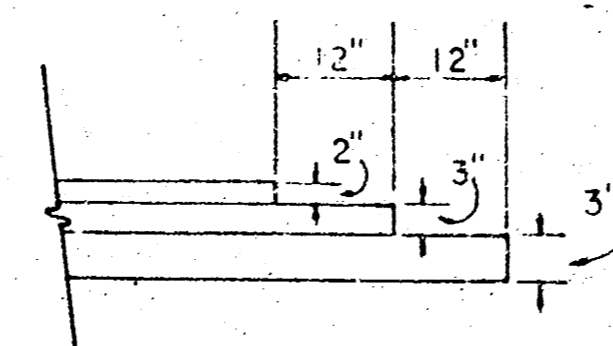

TRANSVERSE CONSTRUCTION JOINTS SHALL BE CONSTRUCTED IN FLEXIBLE BASE PAVEMENTS AT LOCATIONS WHERE PAVEMENT TEMPORARILY ENDS TO FACILITATE FUTURE PAVEMENT CONSTRUCTION AS SHOWN BY DETAIL. THE COST OF CONSTRUCTING THE TRANSVERSE CONSTRUCTION JOINTS SHALL NOT BE MEASURED OR PAID FOR DIRECTLY BUT SHALL BE INCLUDED IN THE BID PRICE FOR SQUARE YARDS OF ASPHALTIC CONCRETE PAVEMENT.

CITY OF WICHITA KANSAS

DEPARTMENT of PUBLIC WORKS - Engineering
Division.

Dean Sallers Acting CITY ENGINEER

DATE _____ Proj No. 472-76-245-80664-000-000
-001

1/4

B-M: 87-42 "4" Cut on B-Curb at S-E Cor. of Intersection of Hawaiian Beach Rd.
 & Shady Grove 100' W. of C Laura
 B-M: 85-93 "4" Cut on B-Curb at N-E Cor. of Shady Grove & Parklawn 100' W. of C Laura
 B-M: 90-39 R-R Spk-N-Side T-P-26' S. Sec. L. MacArthur 260' W. of W-L. Laura
 B-L: Is Set 25' W. of C Laura

Scale: 1"=20'

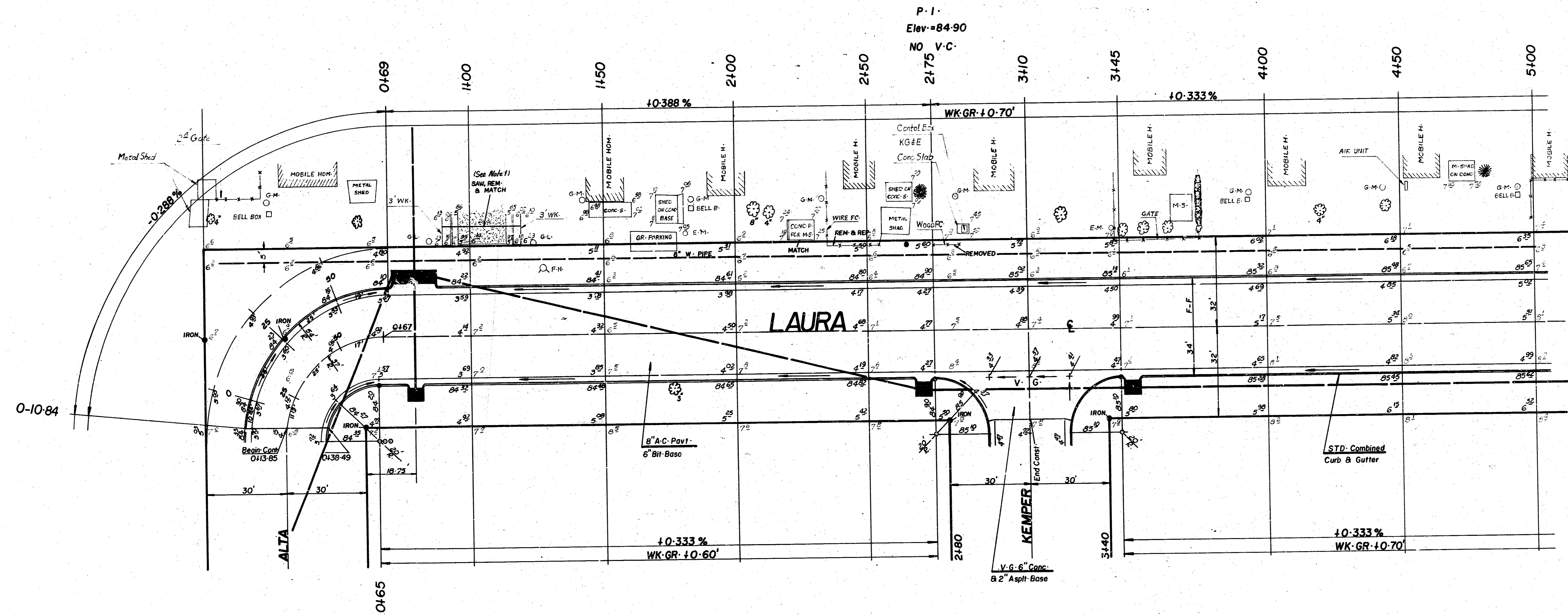

Survey Complete
 Plan set by
 JPC 26
 Checked

	Prop.	City
Excavation	6115.00 cy	848.18 cy
10%	611.50 cy	84.82 cy
Total	6726.50 cy	933.00 cy
Comp. Fill	0	0
Manipulation	4982.75 sy	660.50 sy

Notes

- 1- Saw, Remove & Replace Op 6" A.C., Curb & Gutter To The Same Thickness As Exists. To be Paid As 5-Y. Pavement Removed & Replaced.
- 2- Inlets Structure By Other.
- 3- Field Engineer Shall Take Ties On All Irons & Shall Replace All Such Irons Disturbed During Construction.

CAUTION
 UNDER CONSTRUCTION
 Please do not drive on this road.
 Southwest Bell
 Telephone Co. for Location

SUBGRADE
 TYPE OF SUBGRADE TREATMENT SHALL BE DETERMINED BY THE PUBLIC ENGINEER. SUBGRADE TREATMENT MAY CONSIST OF LIME TREATMENT, CEMENT TREATMENT, SUBGRADE MODIFICATION, OR ANY COMBINATION OF THESE.

LAURA
 From 30' S. of N-L: Lot 13 Riverside Gardens To
 S-L: Mac Arthur Road
 (35' B-B A.C. Pavt./Comb. Curb & Gutter)
CITY OF WICHITA, KS.
 Dean Sellers Acting City Engineer
 Proj. NO. 472-76-245-90664-000-000-001 2/4

FILMED FROM THE BEST AVAILABLE COPY

Scale: 1"=20'

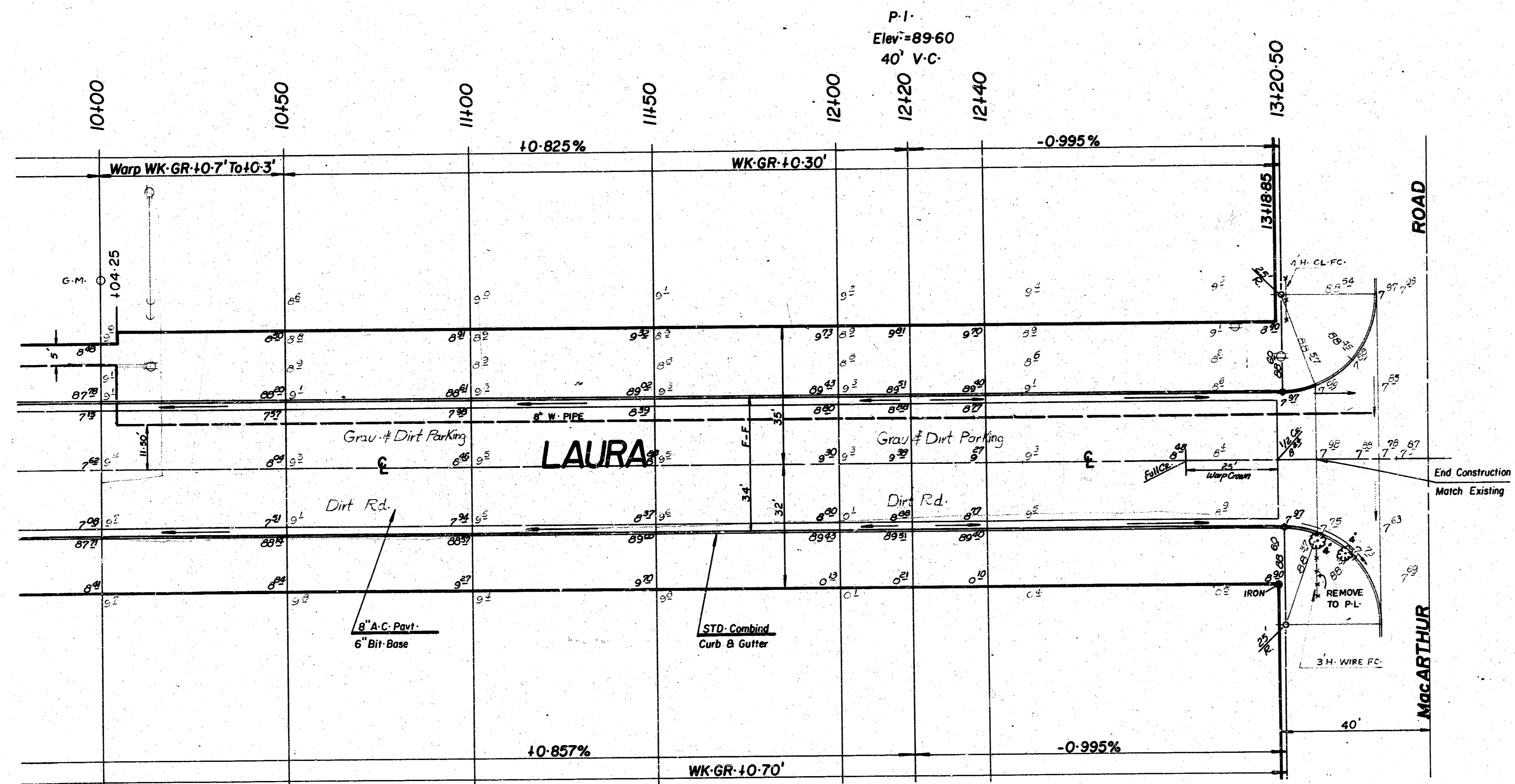

LAURA

4/4