

BENCHMARK:
 City of Wichita Disc 40' East
 and 46' South of Intersection
 of E's of 119th Street West
 and Central
 Elev. = 156.93 (City Datum)
 Elev. = 1,344 (MSL)

SW COR., LOT 102, BLK. 3
 BAY COUNTRY

SW COR. NE1/4,
 SEC. 24, T27S, R2W



SCALE: 1" = 60'
 • = IRON

MINIMUM BUILDING PAD ELEVATIONS FOR LOWEST OPENING TO THE STRUCTURES		
LOT	BLOCK	ELEVATION
1-6	A	148.6
7-39	A	140.6

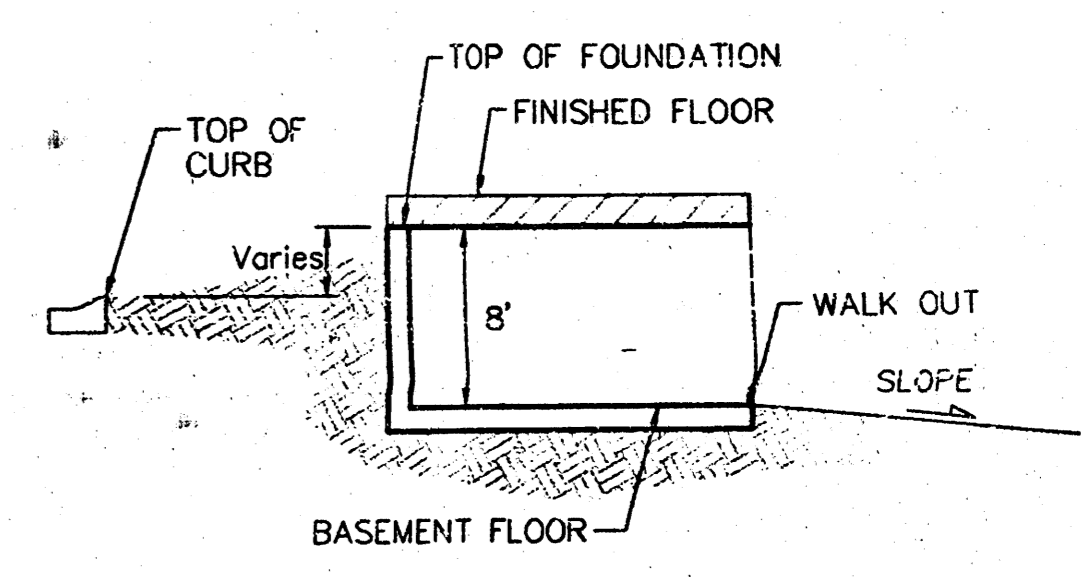
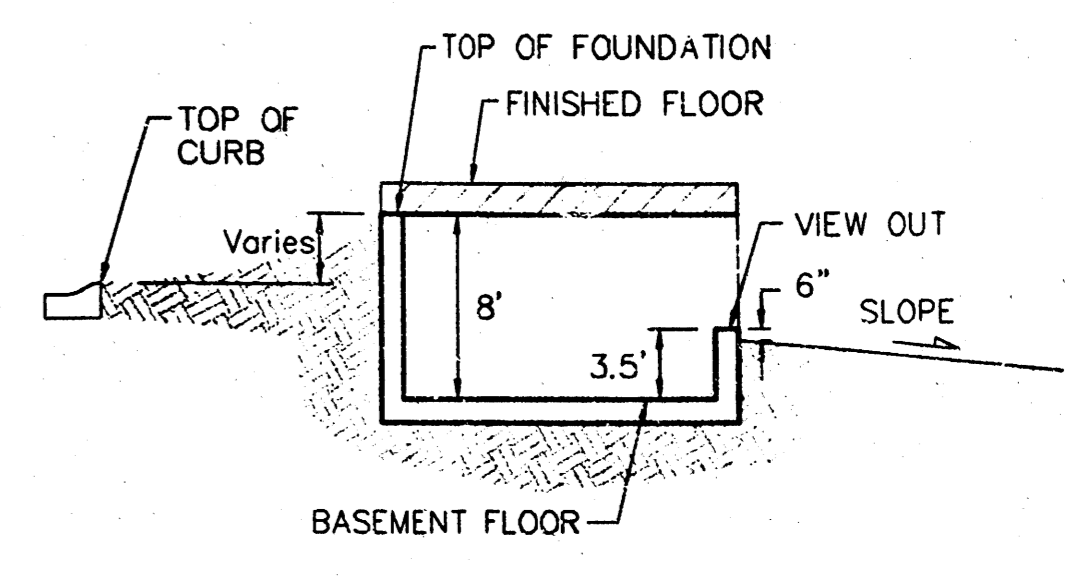

NOTES:

A master grading plan for drainage has been developed for the subdivision and is on file with the City of Wichita, Kansas. Construction of residential structures must follow the master site grading plan elevations which are higher than the minimum pad requirement.

All drainage easements, rights-of-way, or reserves shall remain at established grades or as modified with the approval of the City Engineer of the City of Wichita, Kansas. No obstructions which impede the flow of this drainage system shall be allowed.

Proposed top of foundation elevations are shown on plans. contractor to set finished floor elevations.

All street elevations shown on plans are for top of curb (full-height). Typically roll-type curbs are constructed. Deduct 0.25' from top of curb (full-height).

This Grading Plan is designed with View-Out and Walk-Out easements. Elevations shown at Fear of House (XX.X V.O. and XXX W.O.) are for minimum opening.

All elevations shown on plans are City of Wichita Datum.

* Requires extra-deep foundation.
 * REVISED 11-13-01 BY AEG PER NBW
 DATE OF TOPOGRAPHY FOR SOUTH CUL-DE-SAC & POND - 8/27/01
 REMAINING TOPOGRAPHY PRIOR TO DEVELOPMENT

**APPROVED
 DRAINAGE PLAN**

**BAY COUNTRY 2ND ADDITION
 MASTER GRADING PLAN
 WICHITA, KS**

BAUGHMAN COMPANY P.A.
 ENGINEERING, SURVEYING, & PLANNING
 316 ELLIS • WICHITA, KANSAS 67211
 316-262-7271

DESIGN NBW	DRAW JMW/TMG/AEG	APPROVED	DATE 10-24-01	SCALE NOTED
------------	------------------	----------	---------------	-------------

PROJECT NUMBER: _____ SHEET: **1** OF **1**

PLAT CERNMARKS JAN2002