

STATE	PROJECT NO.	YEAR	SHEET NO.	TOTAL SHEETS
KANSAS	TE-0284-01	2007	31	47

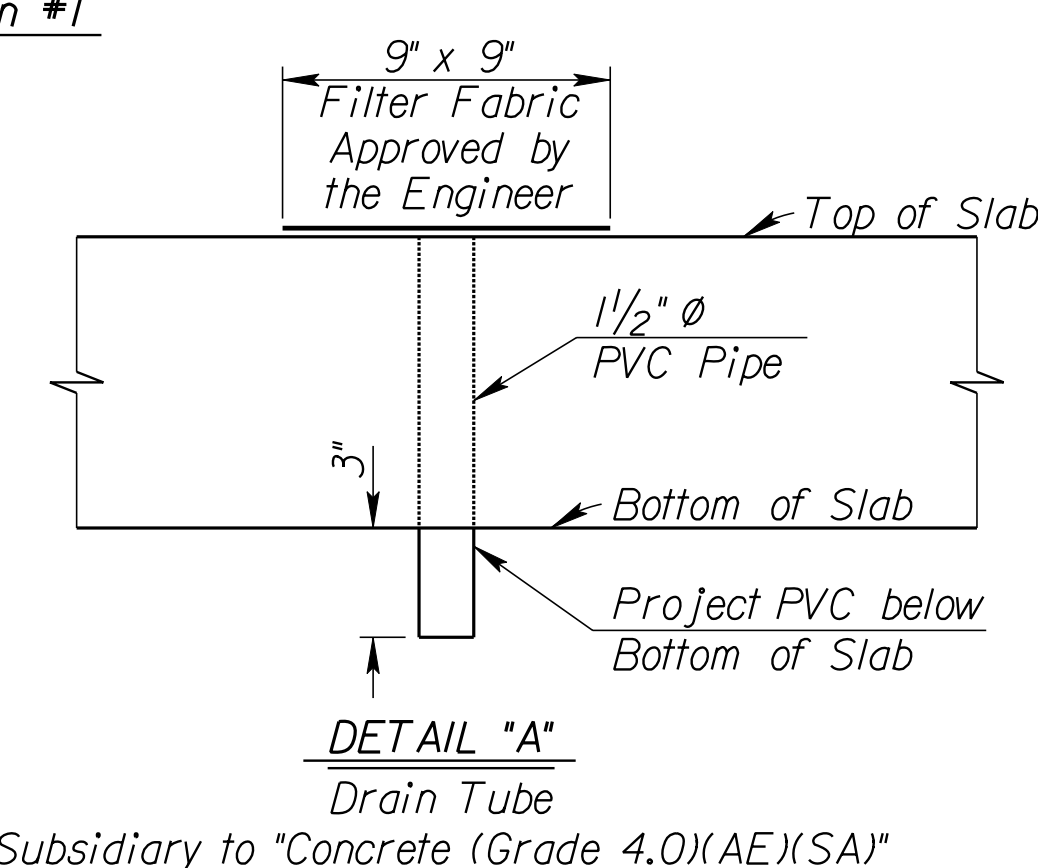
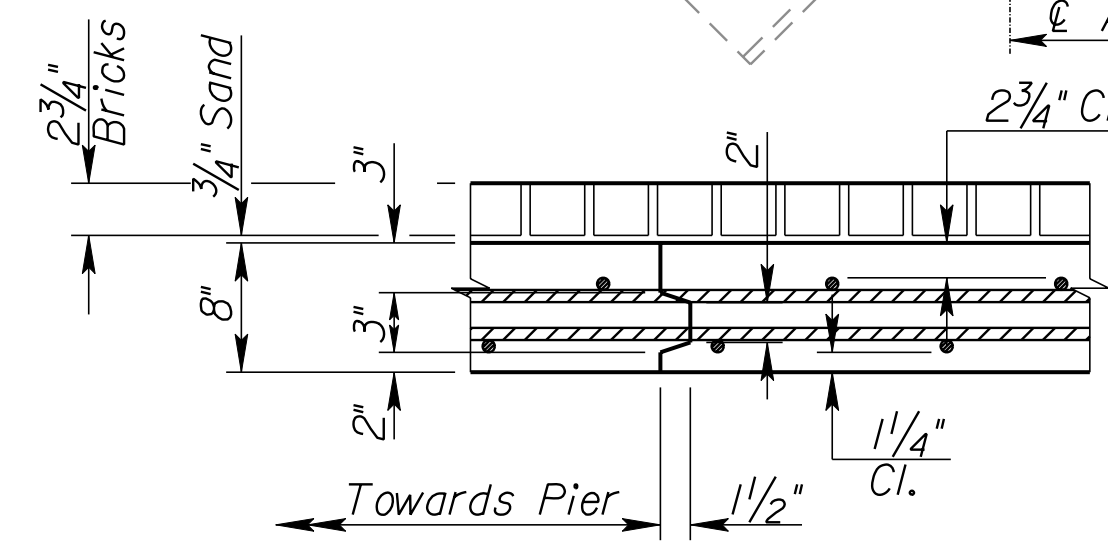
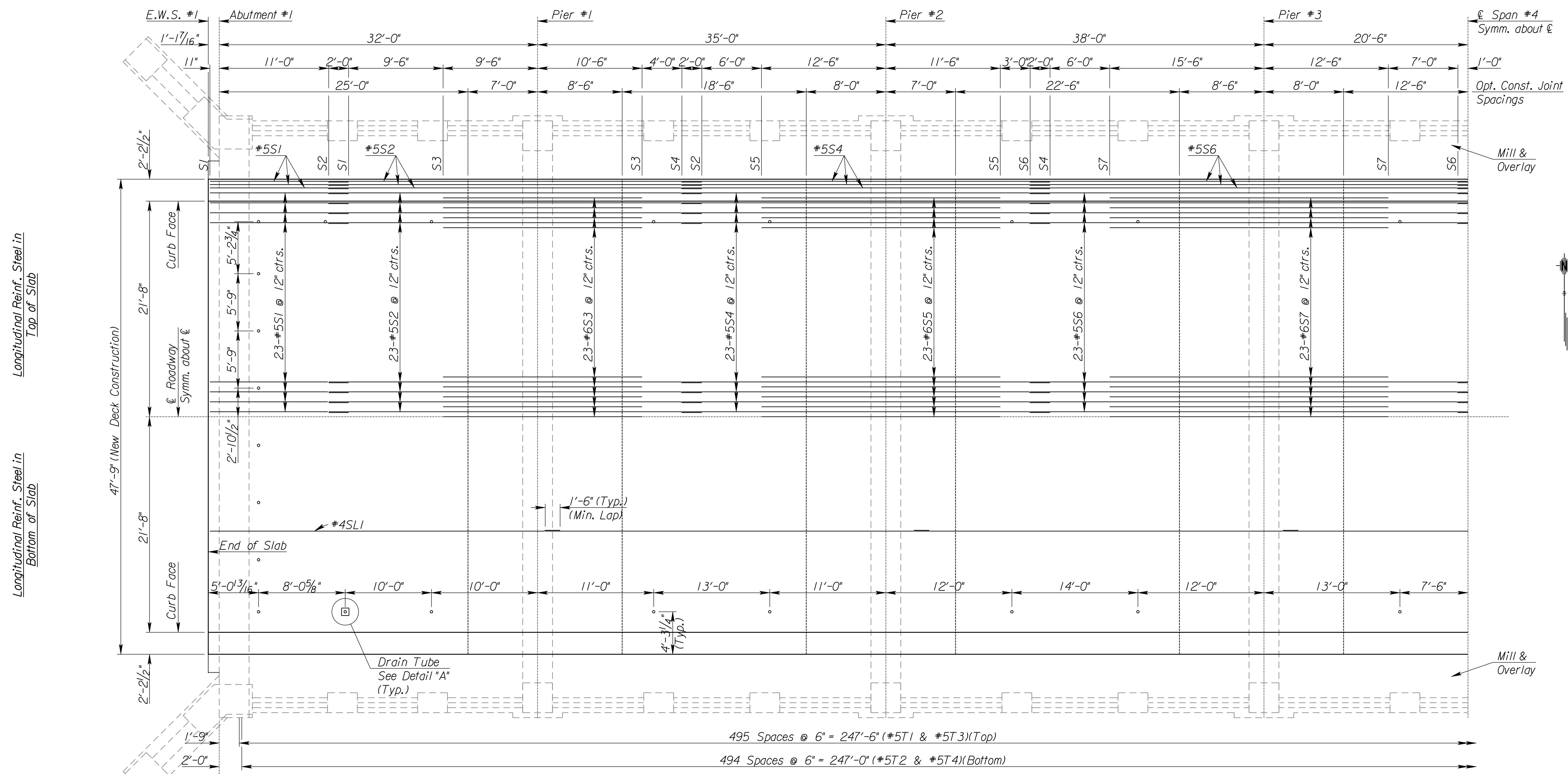

See "Slab Details II" sheet for transverse spacing of slab reinforcing.

See Sh. #32 for Slab Details II.

CITY OF WICHITA  
 JAMES ARMOUR, P.E., CITY ENGINEER  
 13TH STREET BRIDGE OVER  
 LITTLE ARKANSAS RIVER

**SLAB DETAILS I**

**PB PARSONS BRINCKERHOFF**  
 1221. Wichita, Kansas

SCALE: \_\_\_\_\_ DATE: 10/9/2007 DWG NO.: 35750A

K:\35750A\CADD\SHEETS\BRIDGE\13THSLAB01.dgn  
 SURV. JG, CP PLOT CADD DES. AH DR. GBI TR. CKD. BS APP. RG