

TYPICAL SECTION
 *Place sand bed and bricks so that a "rounded" crown grade is achieved, without protruding brick edges near the ℓ Roadway

Keep existing transverse reinforcing projecting from sidewalk. Sandblast to remove corrosion.
 Drill and grout #5 reinforcing to provide 6" ctrs., staggered Top & Btm., as additional transverse reinforcement into sidewalk. Drill and grout is not required, with Engineer's approval, at locations where existing slab transverse reinforcing is in good condition. All material and work is paid for at the set price for the bid item, "Drilled and Grout". Minimum embedment & projection is 1'-6". Use low impact drill to minimize damage to existing concrete.
 "Drill & Grout" quantity includes 1,734-#5 in the sidewalk.

Contractor may, at no additional cost to City, form concrete diagonally from outside of top flange to bottom of existing sidewalk. Revise #5T4 reinforcing accordingly, at direction of Engineer.

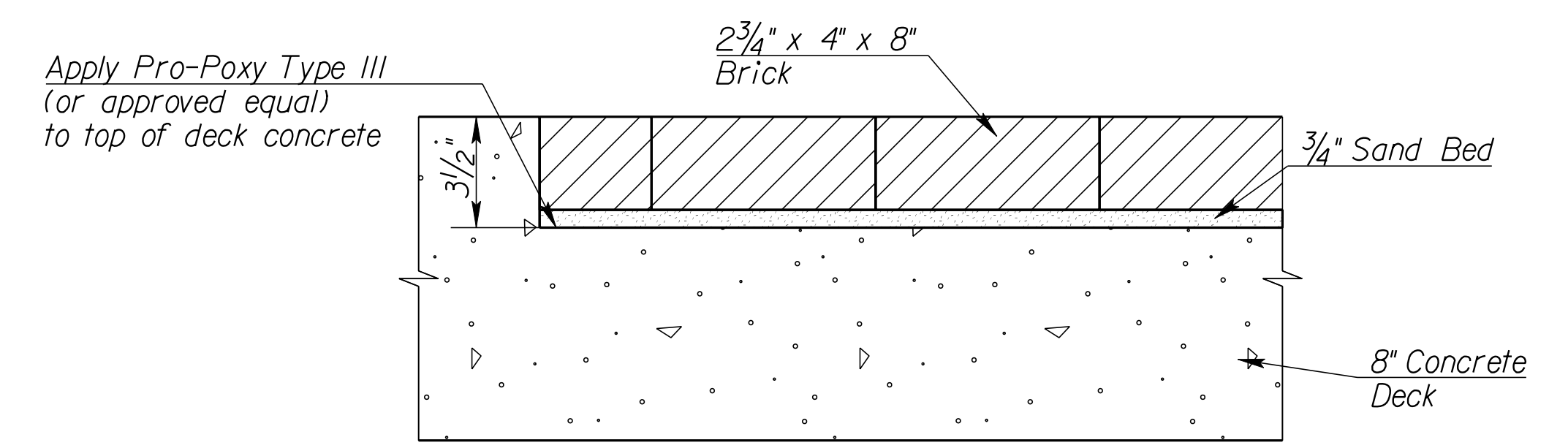

DETAIL OF BRICK PAVING
 Place bricks in a sand bed as per Manufacturer Specifications. Use new paving bricks as specified on the "General Notes" sheet.

Construction Sequence:

- "Shot-blast" the concrete deck surface to clean and profile the substrate.
- Apply coat of Pro-Poxy Type III overlay (or approved equal) with sand to rejection. Use coarse angular material for the sand.
- Remove excess sand.
- Place dry sand bed (concrete sand ASTM C 33). Sand type shall be approved by the Engineer.
- Place bricks with vertical faces touching.
- Fill the joints with an approved polymeric sand. All work with polymeric sand shall be done in accordance with manufacturer specifications. If polymer is an additive to sand, sand component shall be mortar sand ASTM C 144 with the maximum particle size no larger than the joint size. Vibrate bricks into place using a mechanical plate vibrator/compactor. Sweep additional polymeric sand into joints and compact again. Repeat until joints are full.
- Sweep or blow off excess sand, taking care to not force polymeric sand out of joints.
- Saturate joints with water, taking care to not force sand out of joints. Use of a pressure washer is NOT allowed. Allow polymeric sand to dry, with no foot or vehicle traffic for a minimum of 4 hours after flooding of joints.

Conform to Brick Industry Association technical specifications.

See Sh. # 8 for "Paving Bricks" bid item.

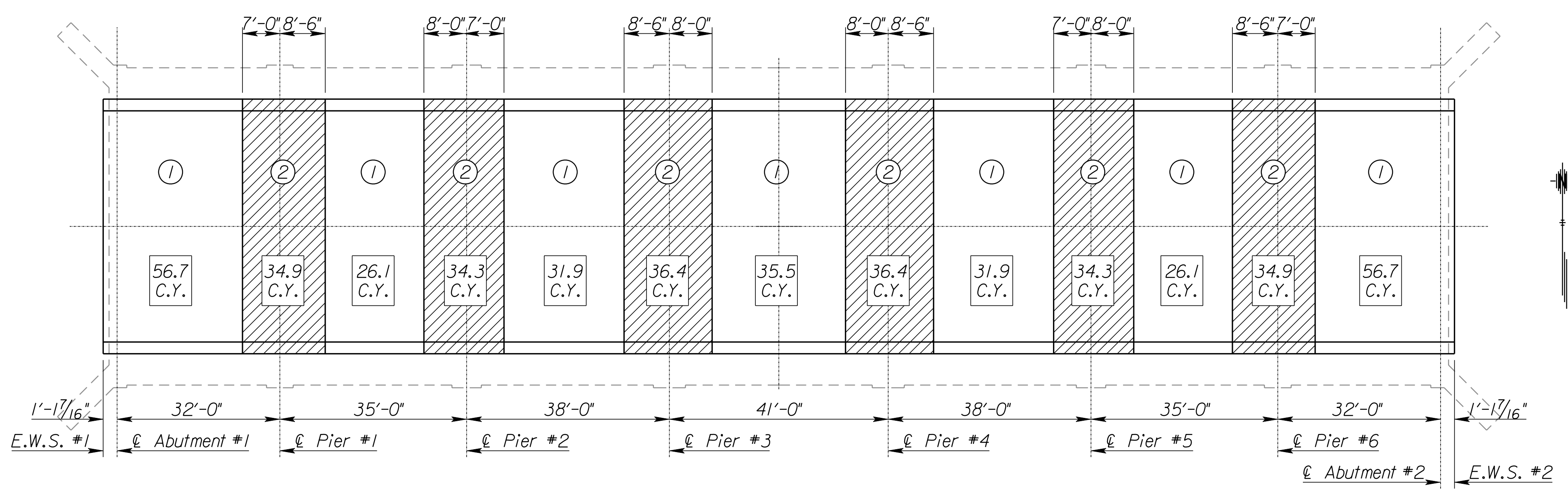

CONCRETE PLACING SEQUENCE

Segmental, combined or continuous pours are allowed by an approved alternate placing sequence. Any discontinuous pour must stop at a construction joint short of a pier. Contractor to pour as much of bridge as possible to expedite construction.

The Contractor may place the corral rail continuously from one end of the bridge to the other.

Place and hand vibrate all concrete for the abutment and pier diaphragms above the construction joint to the bottom of the deck just prior to the normal paving train operations. Do this work in a manner to avoid a cold joint in either the abutments or pier diaphragms.

K:\35750A\CADD\SHEETS\BRIDGE\13THSLAB02.dgn SURV. JG, CP | PLOT CADD | DES. RG BS APP. CKD. GBI TR. AH DR.

CITY OF WICHITA JAMES ARMOUR, P.E., CITY ENGINEER 13TH STREET BRIDGE OVER LITTLE ARKANSAS RIVER SLAB DETAILS II		
PB PARSONS BRINCKERHOFF 122. Wichita, Kansas		
SCALE	DATE 10/9/2007	DWG NO. 35750A