

**BANDED SIGN MOUNTING BRACKET DETAIL**

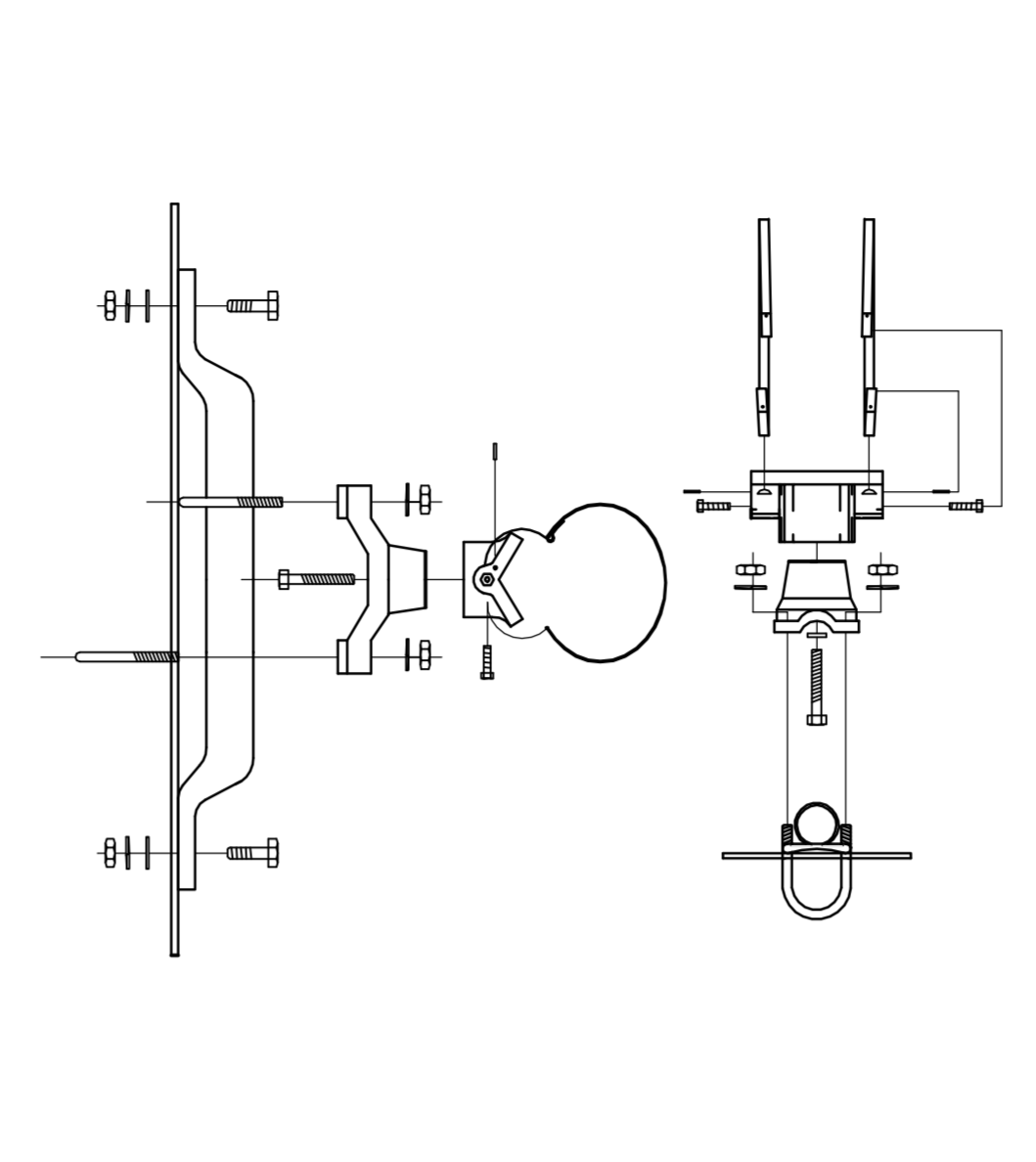

**TYPE I SIGNAL MOUNTING BRACKET ASSEMBLY DETAIL**

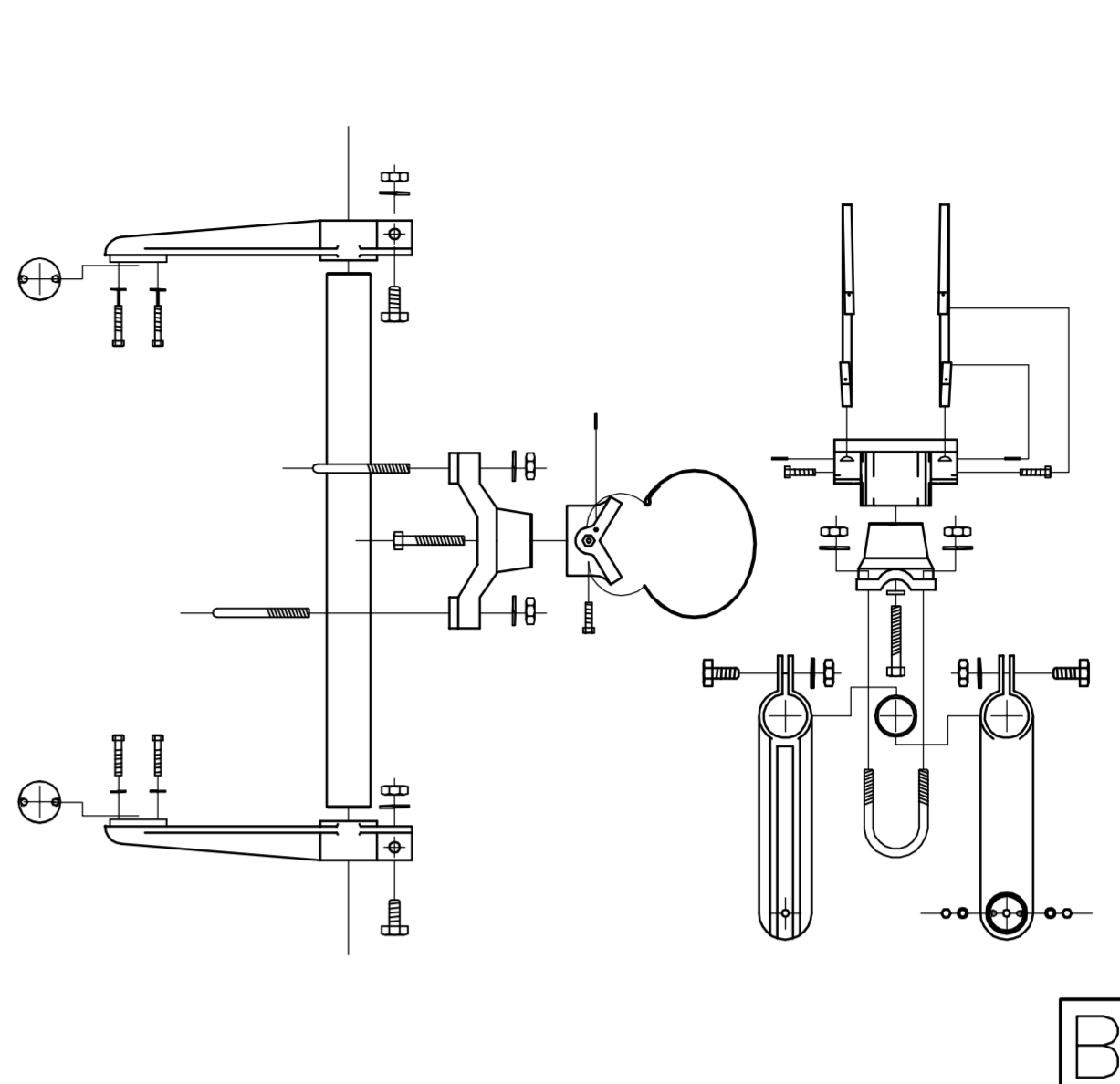

**STANDARD SIGNING**

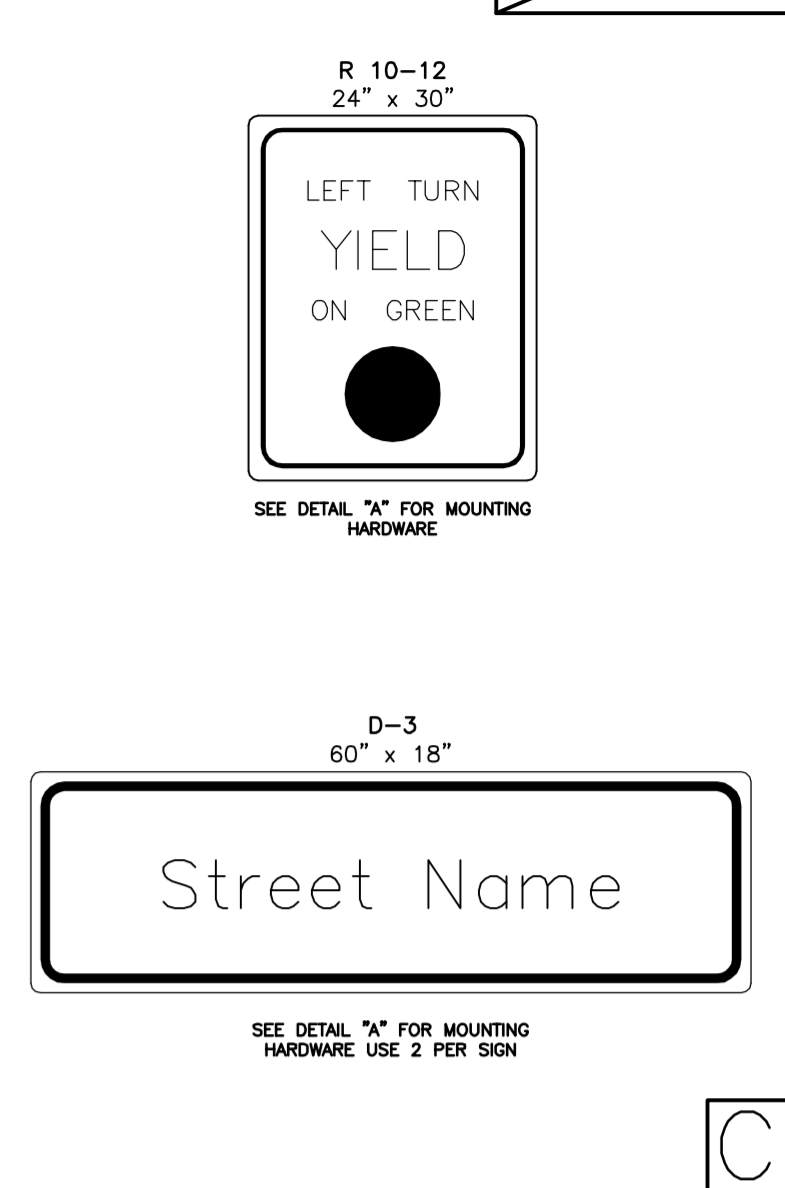

**TYPE III SIDE-OF-POLE MOUNTING BRACKET ASSEMBLY**

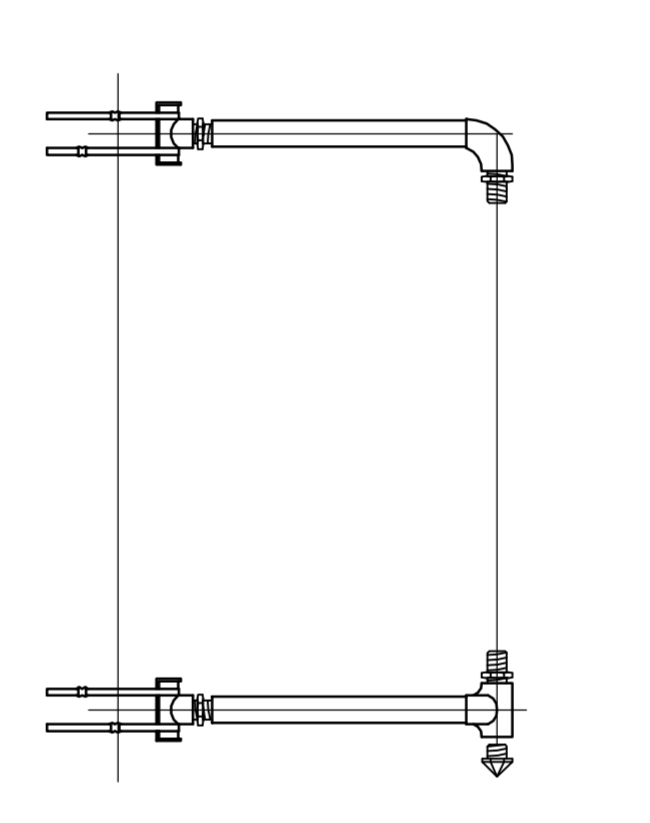

**TYPE II SIGNAL MOUNTING BRACKET ASSEMBLY (SIDE-OF-POLE)**

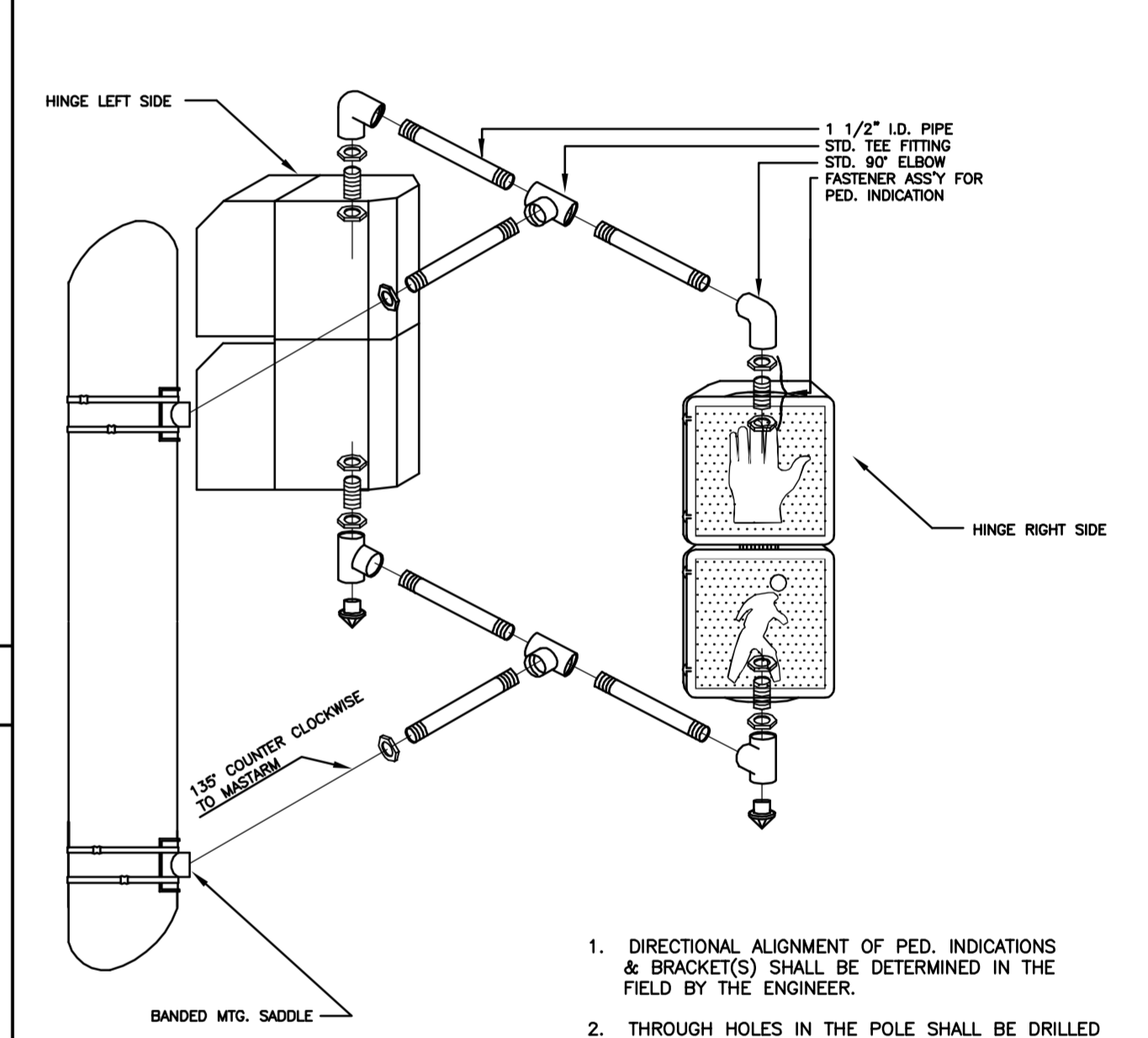

1. DIRECTIONAL ALIGNMENT OF PED. INDICATIONS & BRACKET(S) SHALL BE DETERMINED IN THE FIELD BY THE ENGINEER.
2. THROUGH HOLES IN THE POLE SHALL BE DRILLED AND WELL REAMED TO PREVENT CABLE CHAFING.
3. HINGE PEDESTRIAN SIGNAL DOORS AWAY FROM POLE.

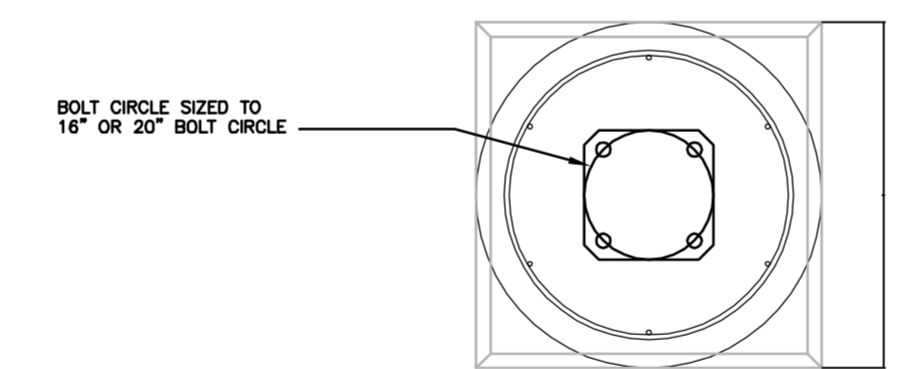

**REBAR CAGE**

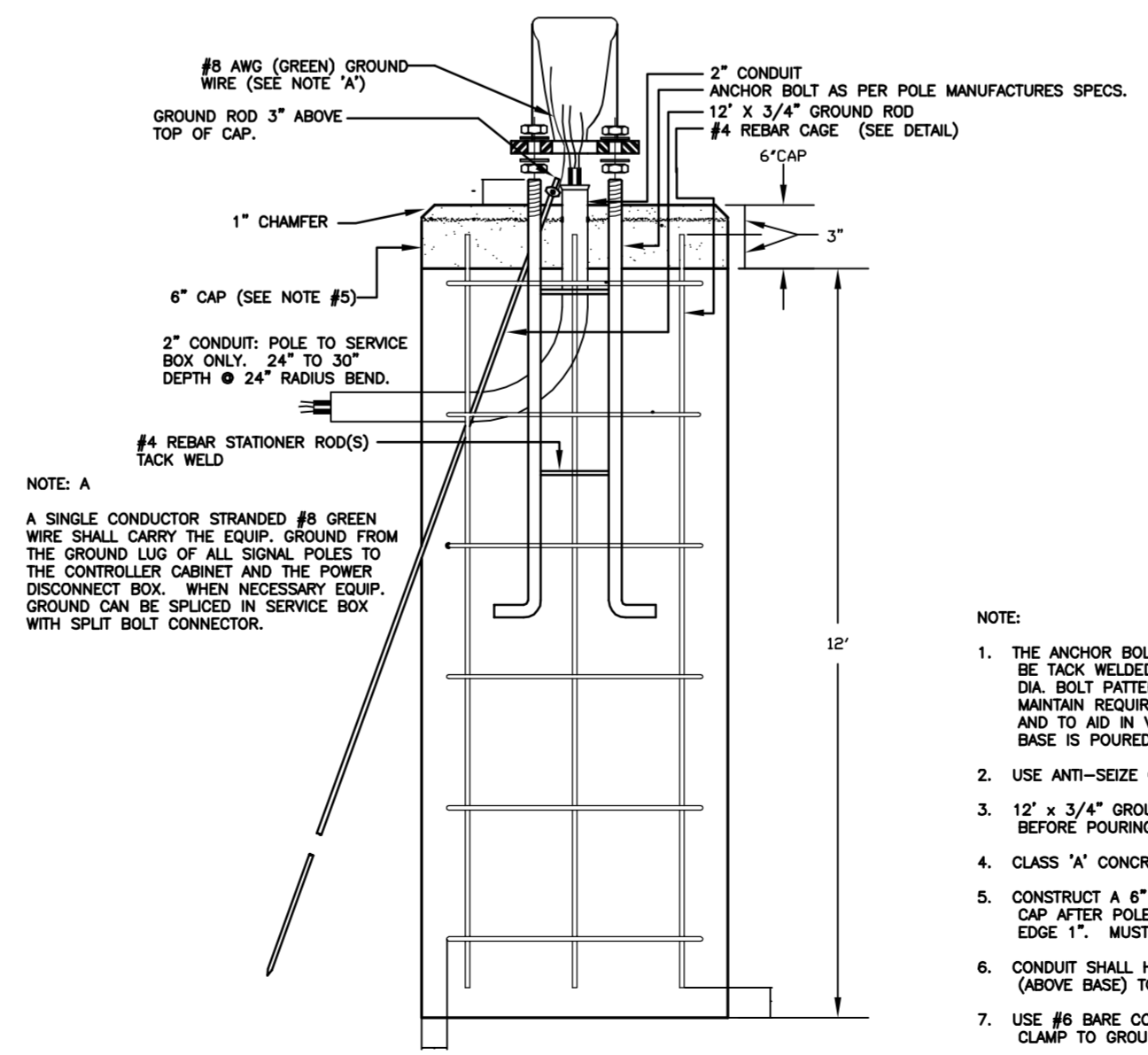
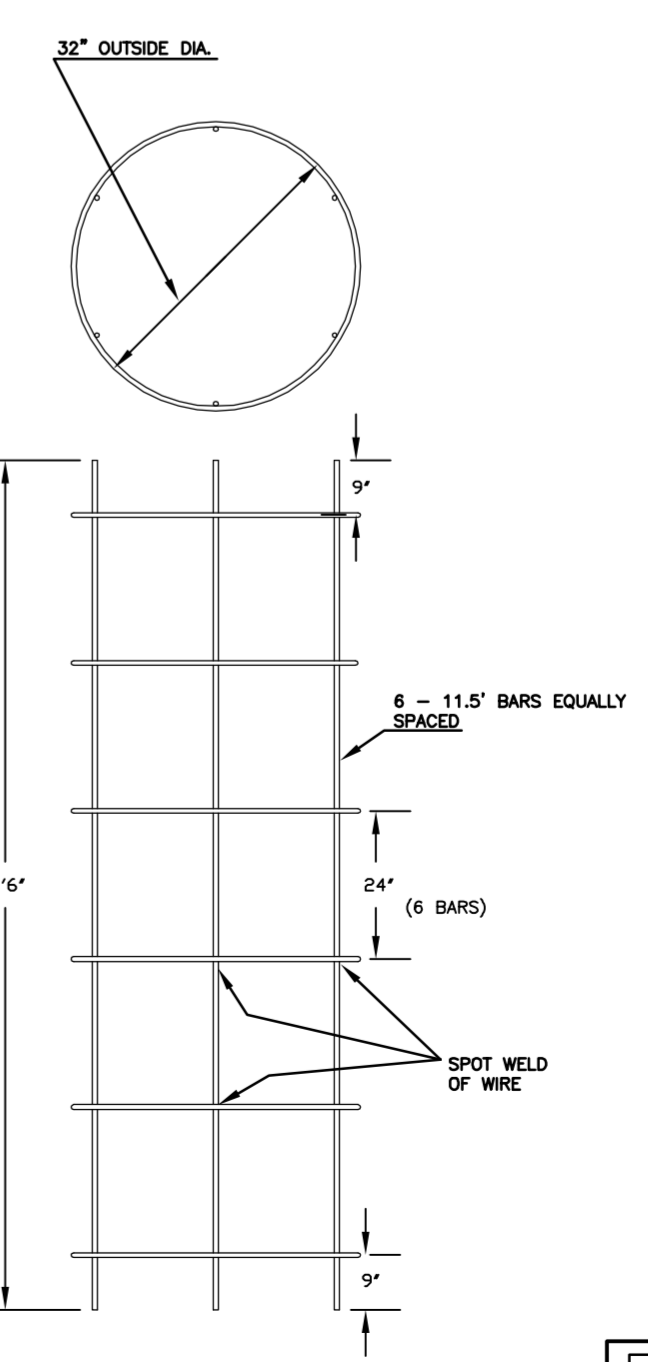

- NOTE:**
1. THE ANCHOR BOLTS FOR THE SIGNAL POLE SHALL BE TACK WELDED TOGETHER IN A 16" OR 20" DIA. BOLT PATTERN (ON CENTERS AS SHOWN) TO MAINTAIN REQUIRED BOLT CONFIGURATION PATTERN AND TO AID IN VERTICAL POSITIONING WHILE CONCRETE BASE IS POURED.
  2. USE ANTI-SEIZE COMPOUND ON ALL THREADS.
  3. 12" x 3/4" GROUND ROD TO BE POSITIONED BEFORE POURING BASE.
  4. CLASS 'A' CONCRETE SHALL BE USED TO CONSTRUCT BASE.
  5. CONSTRUCT A 6" THICK x 36" SQUARE CONCRETE CAP AFTER POLE HAS BEEN ERECTED & PLUMBED. CHAMFER EDGE 1". MUST BE APPROVED BY ENG. BEFORE POURED.
  6. CONDUIT SHALL HAVE PLASTIC (OR METAL) BUSHING (ABOVE BASE) TO PREVENT CABLE CHAFING.
  7. USE #8 BARE COPPER GROUND CONDUCTOR FROM CLAMP TO GROUND BOLT IN ACCESS HOLE.

MACARTHUR ROAD PAVING - MERIDIAN AVENUE TO SENECA STREET		
<b>STEEL SIGNAL POLE ASSEMBLY DETAILS</b>		
NO SCALE		
PROJECT NUMBER <b>472-84580</b>		
DRAWN BY: T.M.	APPROVED BY:	REVISED BY: T.M.
DATE: FEB. 96		DATE: MAY, 97
CITY OF WICHITA DEPARTMENT OF PUBLIC WORKS		
NO SCALE		
ENGINEERING DIVISION SCOTT LOGAN, TRAFFIC ENGINEER		SHEET 68 OF 132