

EXPANSION JOINT

NOTE: Extra Thickness to be Subsidiary to Price of Square Yards Pavement

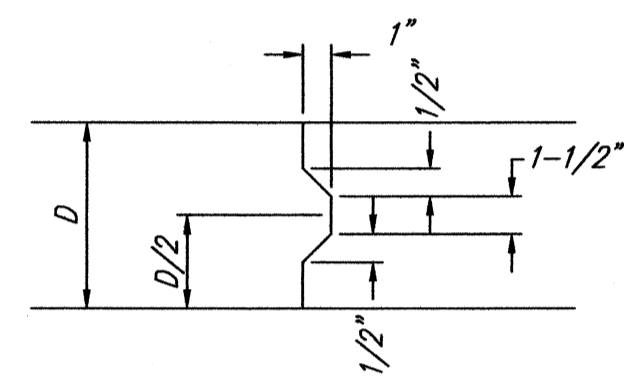

KEYWAY DETAIL

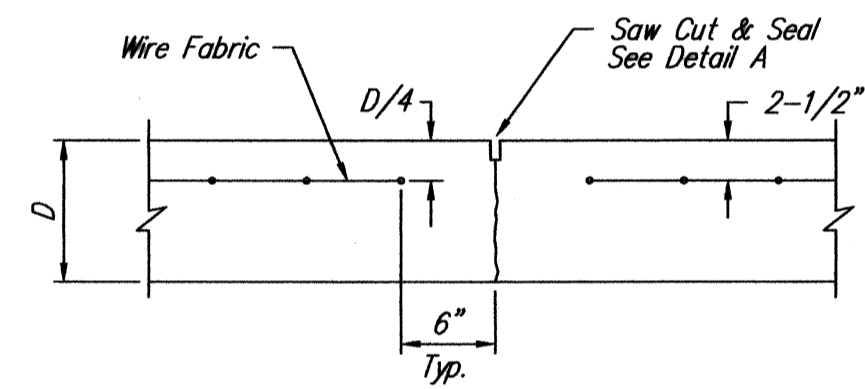

CONTRACTION JOINT DETAIL (C.J.)

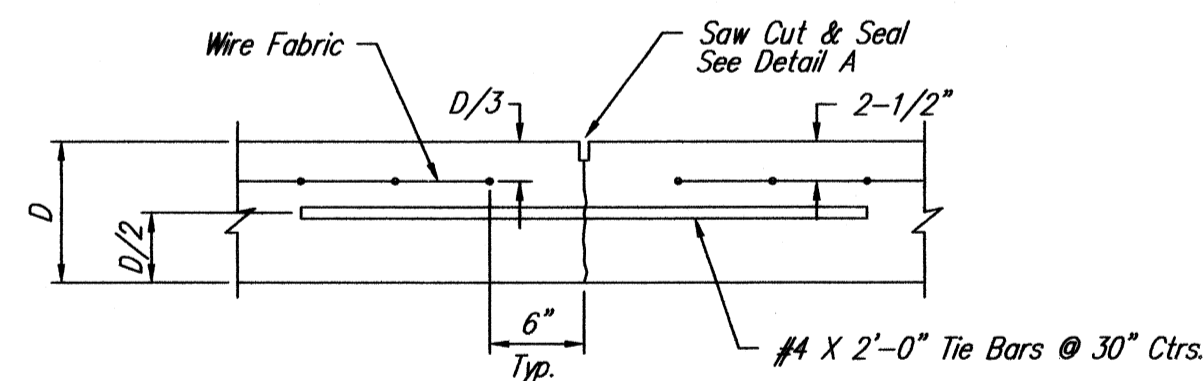

LONGITUDINAL JOINT DETAIL (L.J.)

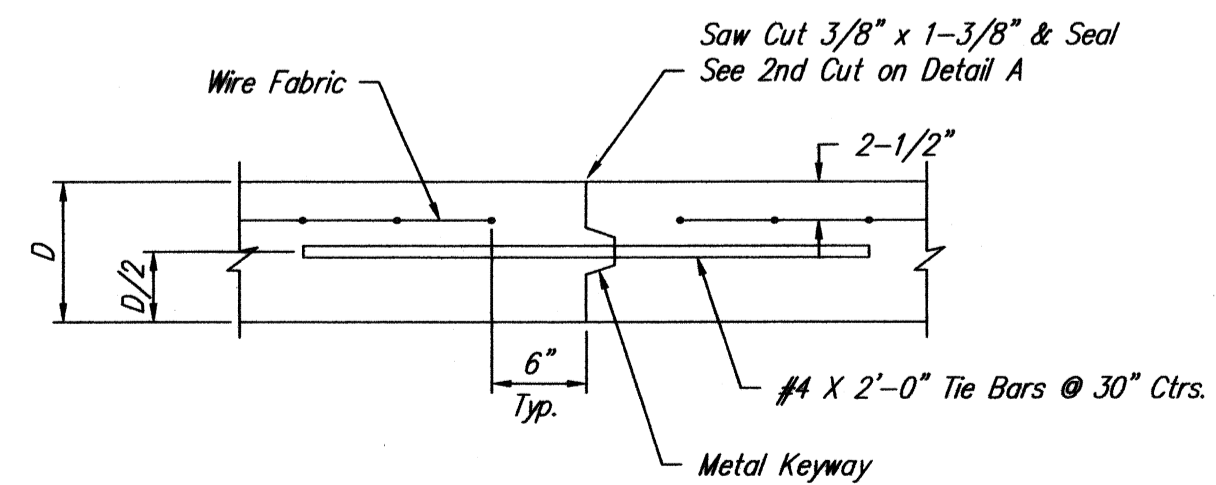

OPTIONAL LONGITUDINAL JOINT DETAIL (L.J.)

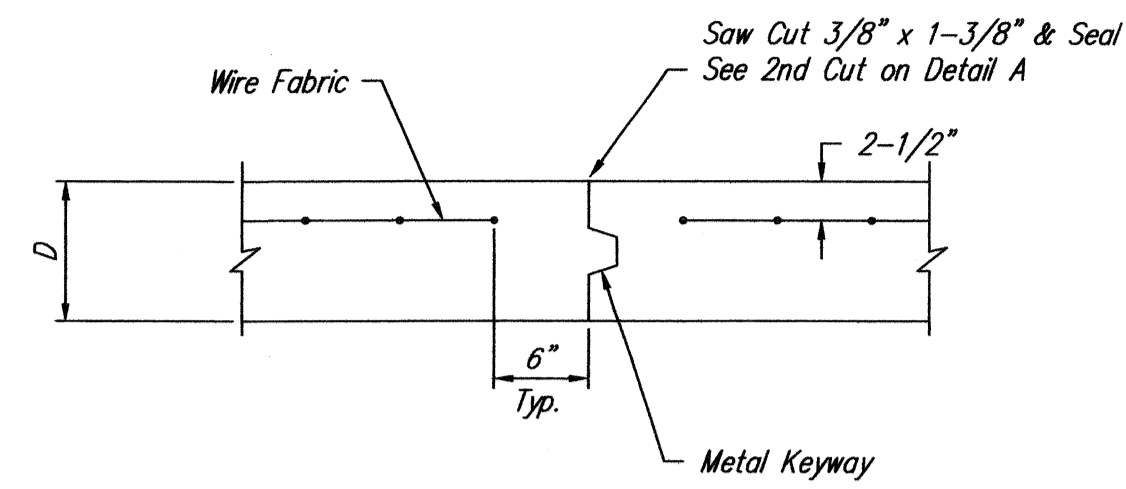

OPTIONAL CONTRACTION JOINT

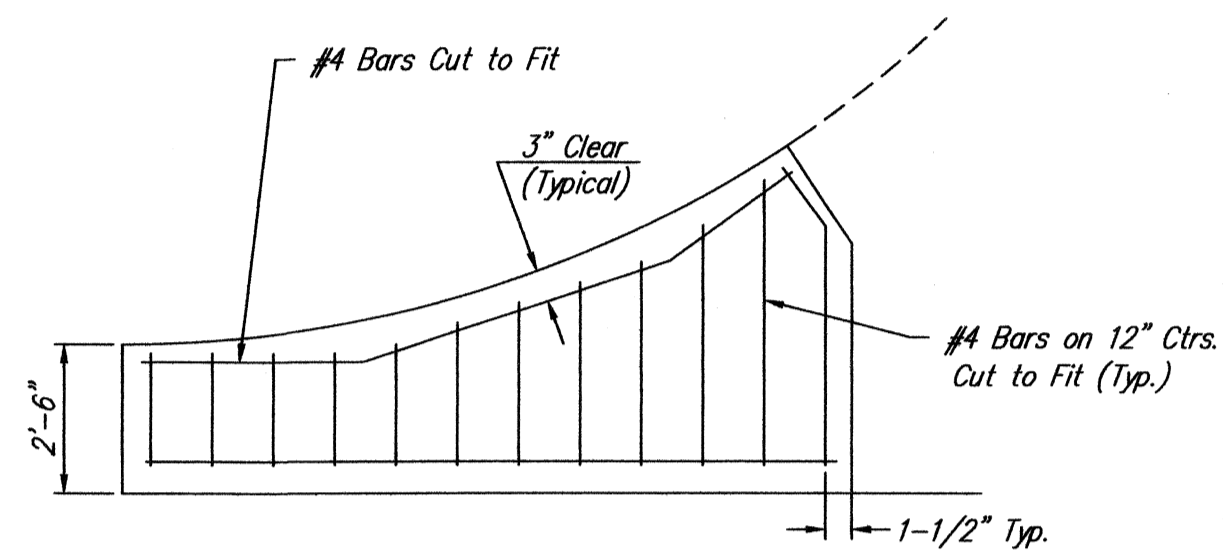

WING REINFORCING DETAIL

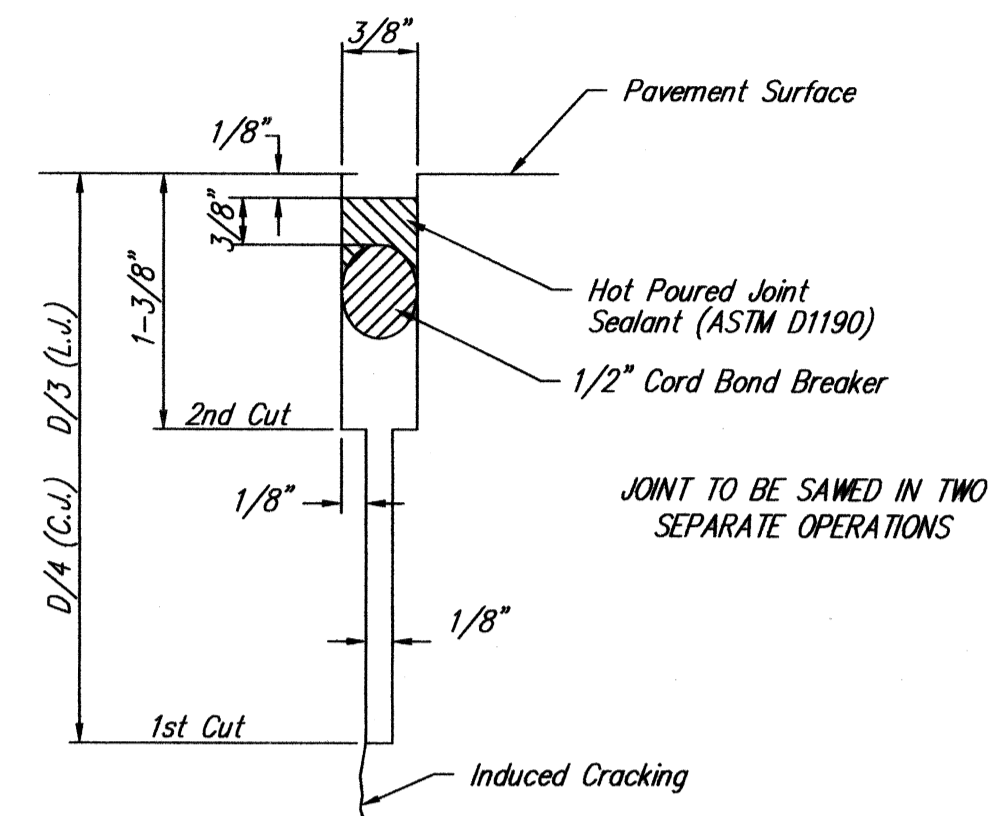

SAW JOINT DETAIL

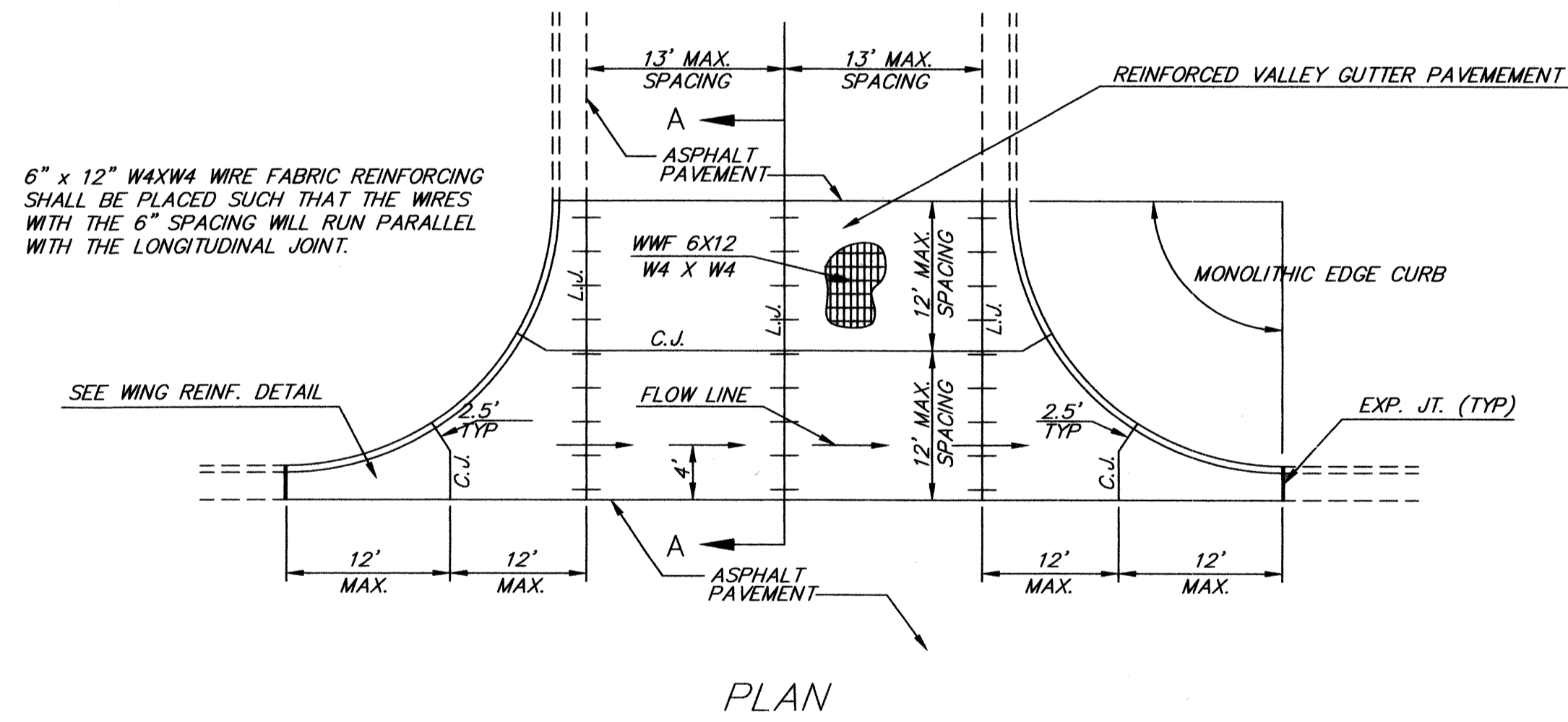

PLAN

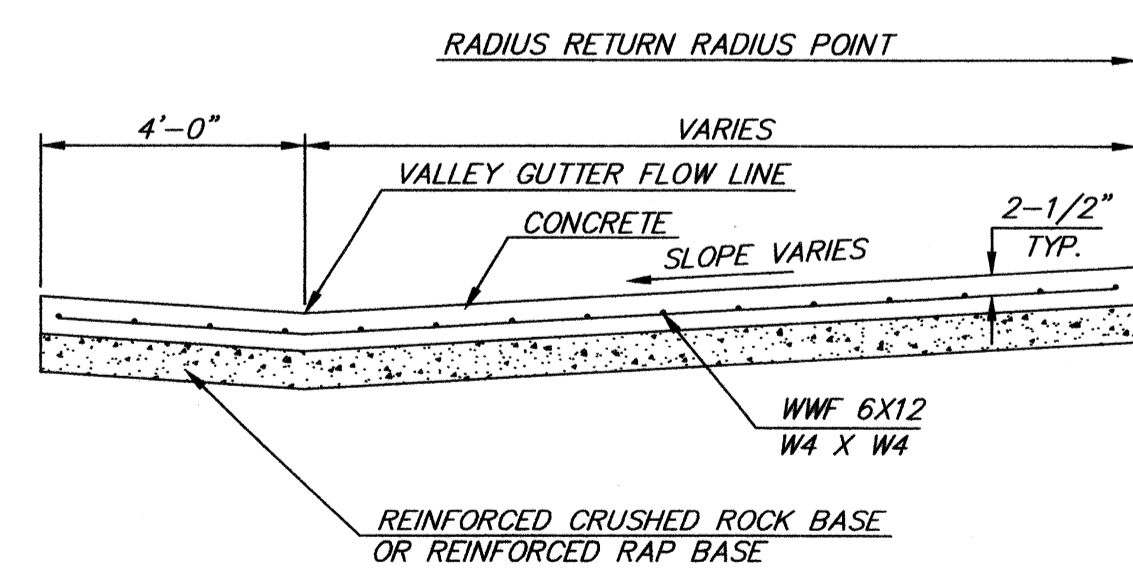

SECTION A-A

REINFORCED VALLEY GUTTER DETAIL

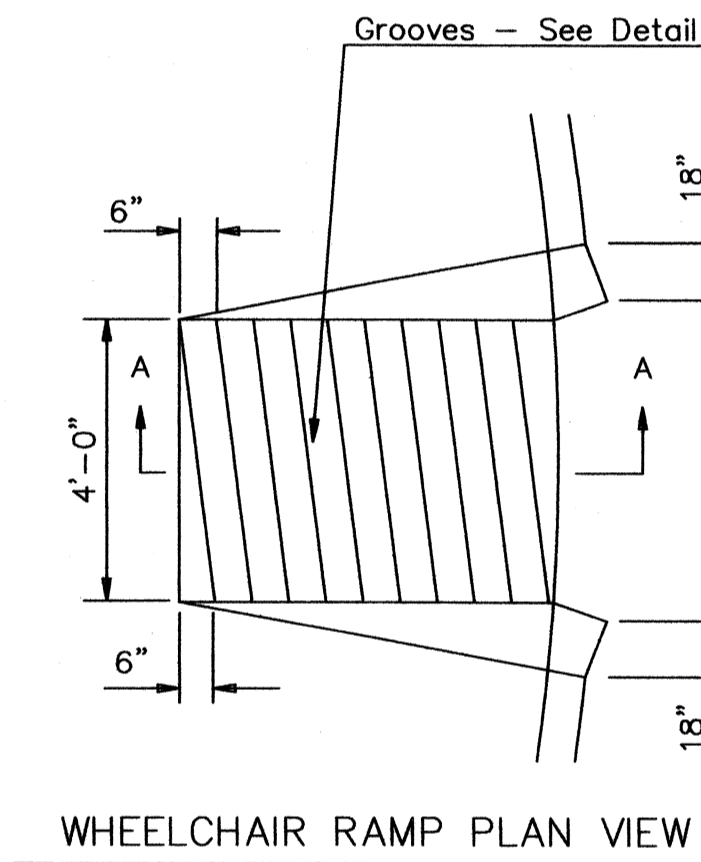

WHEELCHAIR RAMP PLAN VIEW

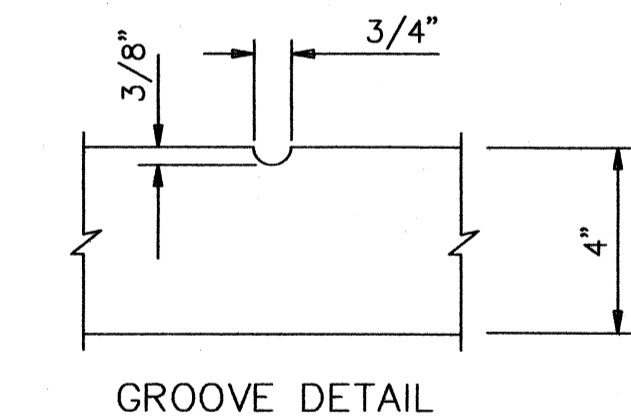

GROOVE DETAIL

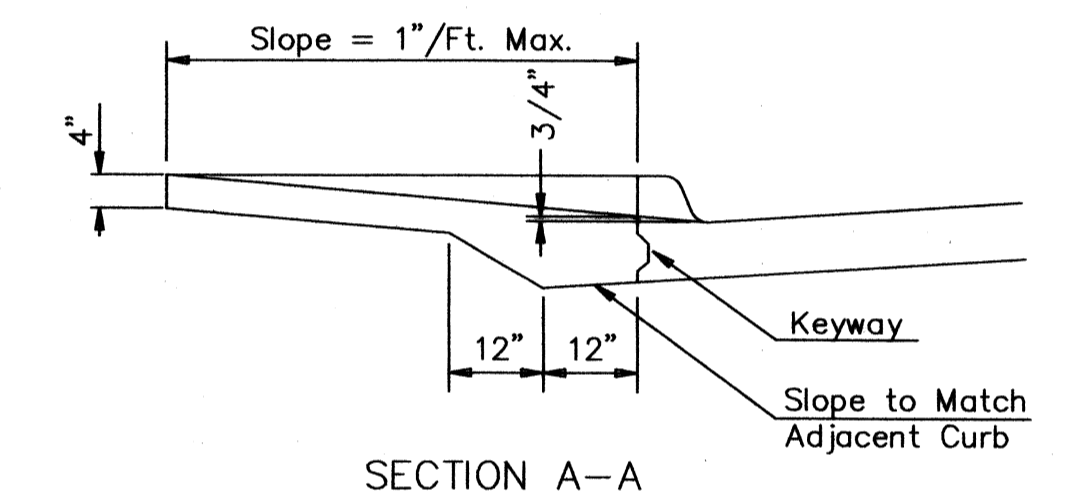

SECTION A-A

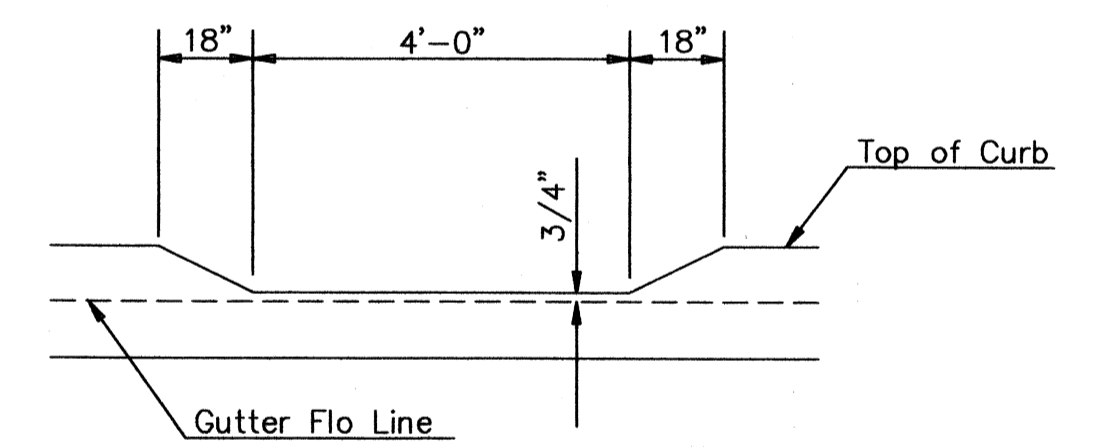

DEPRESSED CURB DETAIL

WHEELCHAIR RAMP DETAIL

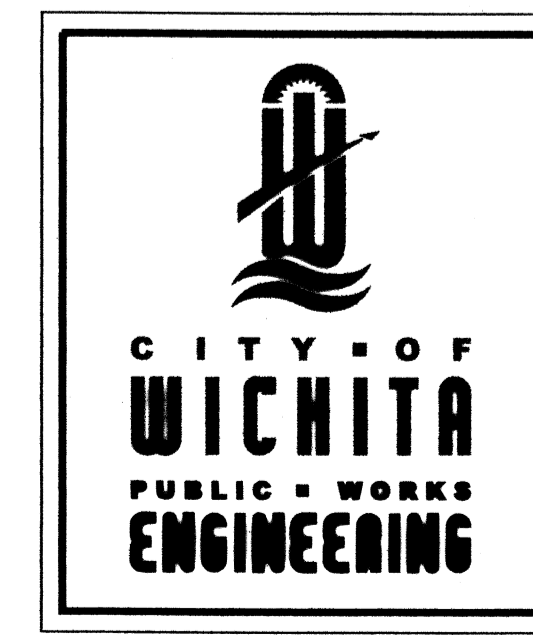

VALLEY GUTTER DETAILS			
WHEELCHAIR RAMP			
DETAILS			
CITY ENGINEER			
JAMES L. ARMOUR, P.E., L.S.			
PROJECT NUMBER	OCA NUMBER	DATE	
XXX-XXXX	XXXXXX	MM/YY	
CITY ENGINEER'S OFFICE		DESIGN	DRAWN
CITY HALL - SEVENTH FLOOR		ABC	DEF
455 NORTH MAIN STREET		SHEET	
WICHITA, KANSAS 67202-1620		24	
(316) 268-4501			
(316) 268-4114 FAX			