

FHWA REGION NO.	STATE	PROJECT NO.	YEAR	SHEET NO.	TOTAL SHEETS
7	KANSAS	54-87 K-6657-01	2002	139	1122

DATE	
BY	
REFERENCES NOTED	
REFERENCES CHECKED	

DSNR: C.O.W. OPER: DJW SCALE: 100
 i:/1997/97362/sws/standards/gutterinlet.DGN 2-16-2001 10:39:22 LAST REV: 11-20-01 BY: JGP

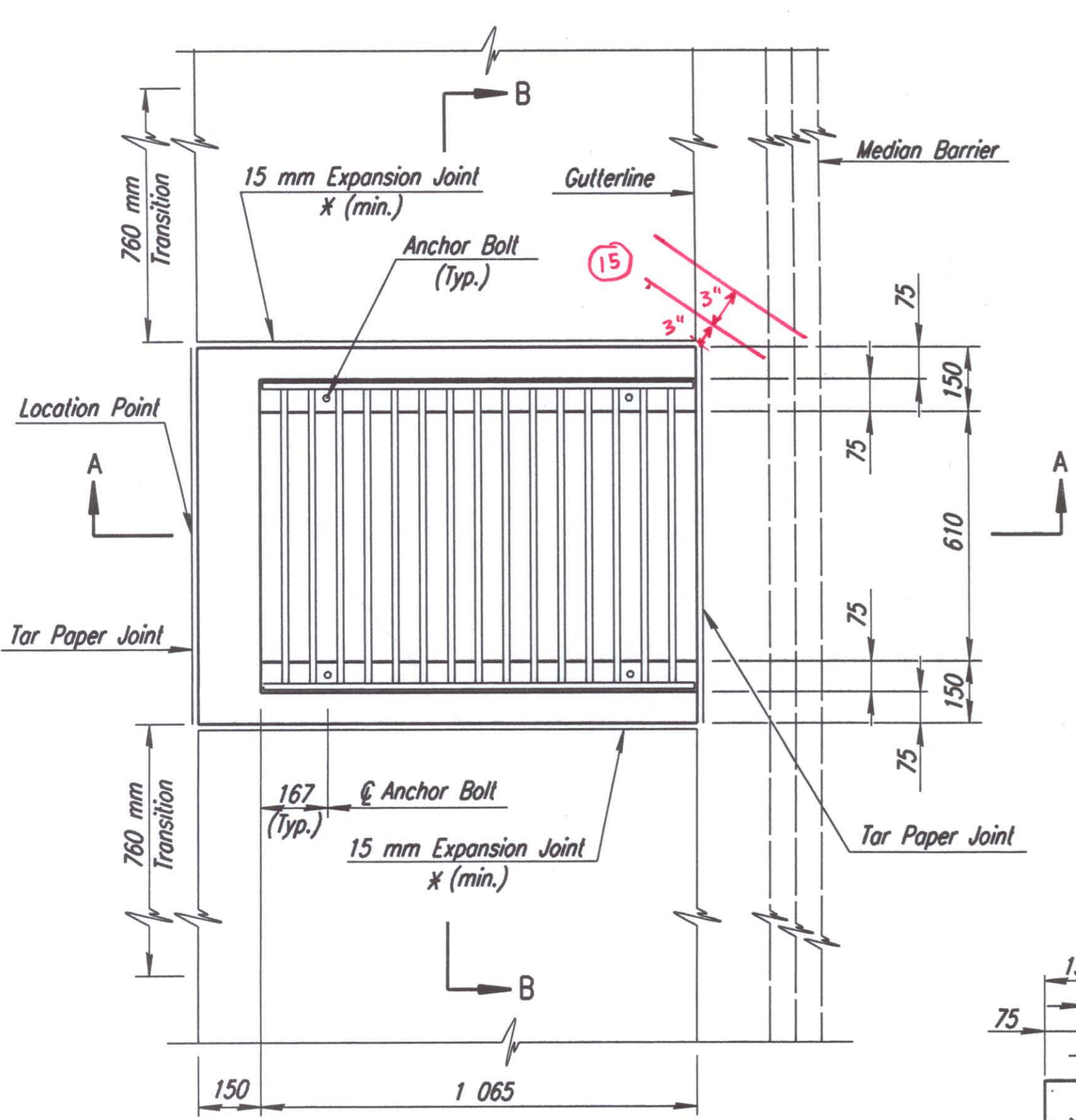

PLAN

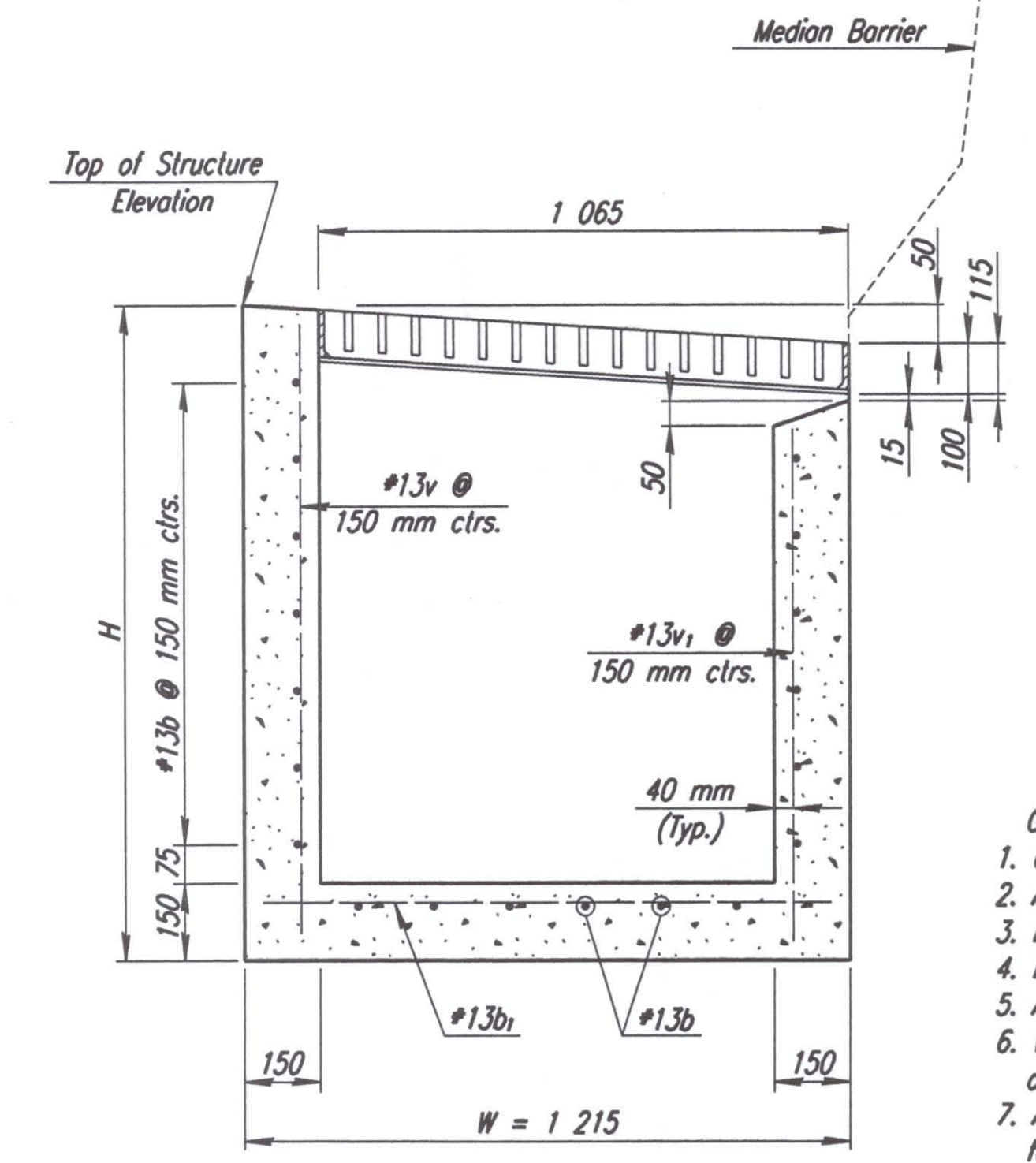

SECTION A-A

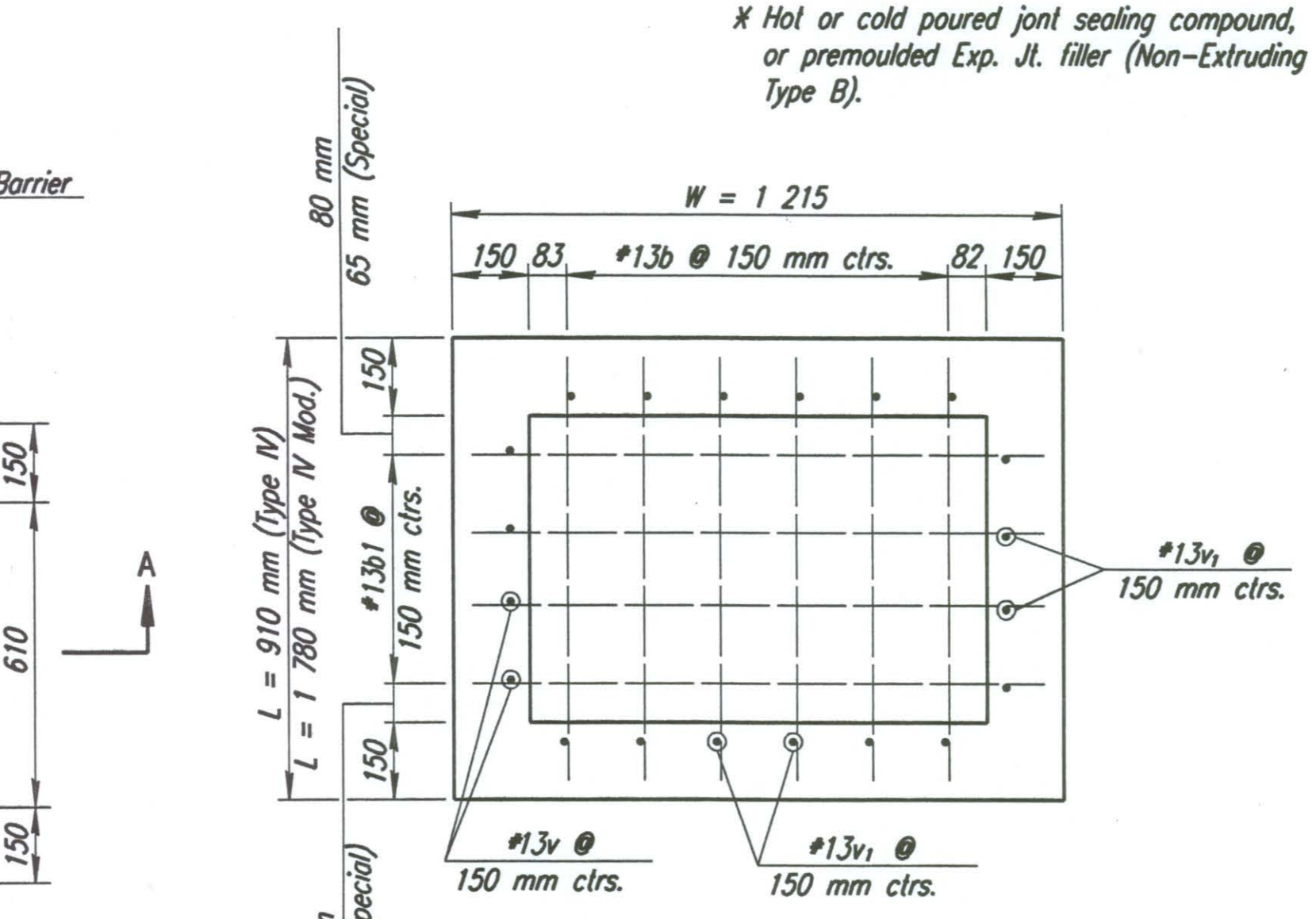

FLOOR

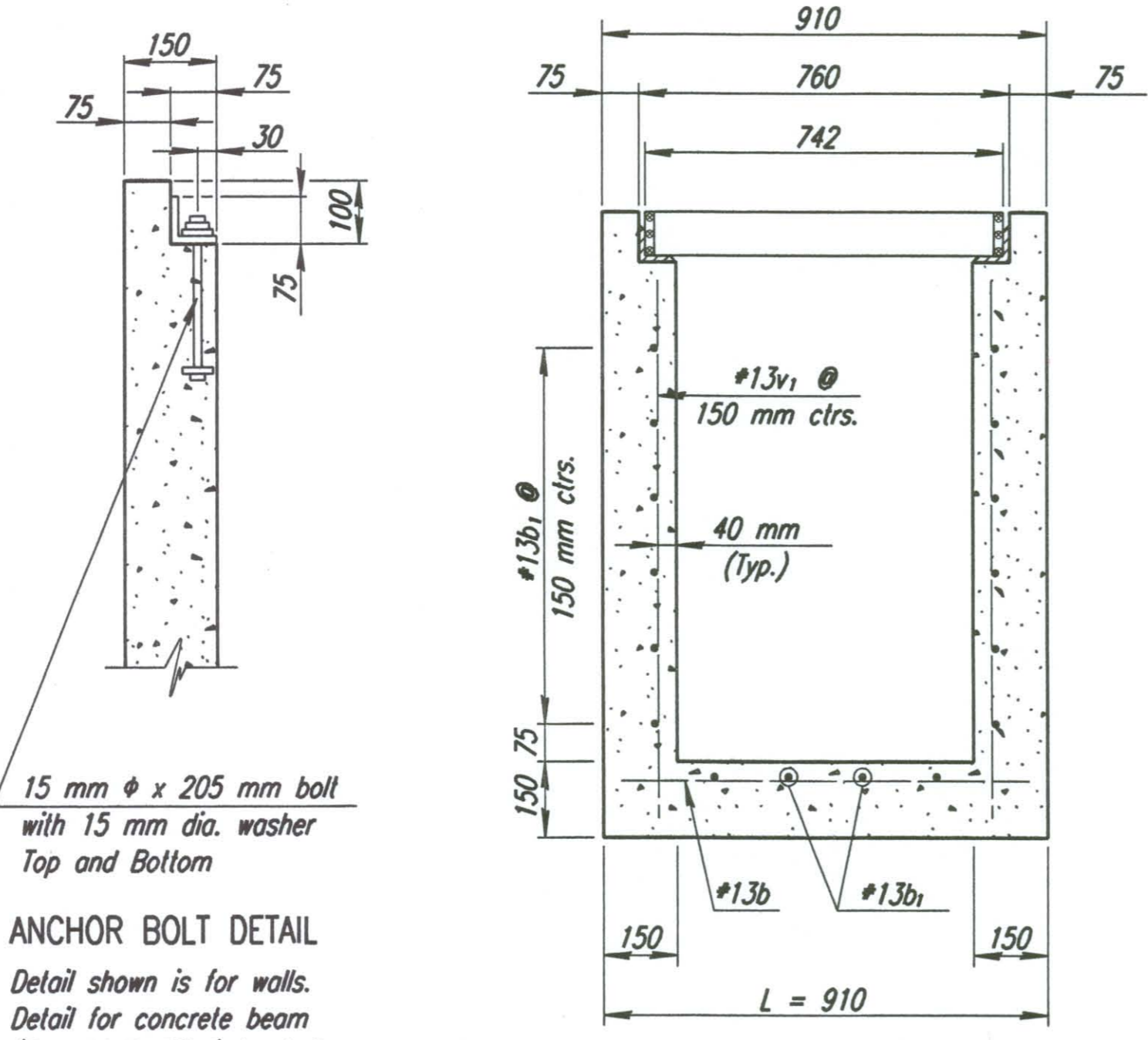

SECTION B-B

ANCHOR BOLT DETAIL
 Detail shown is for walls. Detail for concrete beam (Type IV Modified) is similar.

- GENERAL NOTES:**
- Use Class AAA Concrete throughout.
 - All exposed edges shall be finished with an edging tool.
 - Reinforcing bars shall be bent around pipe.
 - No deductions in concrete quantities shall be made for pipe openings.
 - At the contractor's option, Class AAA Concrete (AE) or mix used in concrete pavement may be used throughout.
 - When so ordered by the Engineer, the top of the inlet shall be sloped slightly to approximately fit the ground line or other conditions.
 - All exposed cast iron surfaces shall be painted either in the shop or in the field with one coat of a zinc dust paint, followed by two field coats of aluminum paint.
 - Floor of inlet shall be shaped as shown in various "Examples" on Reinforced Concrete Manhole Standard No. RD730SL. Concrete used for shaping shall be unreinforced Class A Concrete. No addition in concrete quantities shall be made for shaping floor of inlets.
 - All bars are #13 bars @ 150 mm spacing and shall have a minimum clearance of 40 mm unless otherwise noted on plans.
 - All reinforcing steel shall conform to the requirements of ASTM A615M-96, Grade 420.
 - When directed by the Engineer, small openings may be required in the back of the inlet in order to drain a low area.
 - Reinforcing bars will extend through the opening. No deduction in concrete quantities will be made for these openings.
 - The weight of castings includes no allowance for fillets and overruns. All castings shall be gray iron and shall comply with ASTM A 48M-94, Class 25 S.
 - Shoulder inlets to be set flush to 1/2" below PCCP. Set 3/4" low when inlet near end of CSB.
 - Place X-bar reinforcement at corners of shoulder pavement @ inlets.

GUTTER INLET

Note: No joint in the median traffic barrier shall fall within 610 mm of the inlet walls. Care shall be taken when setting the anchor bolts for the frame, that the bolts are placed in the proper position.

Note: Adjust base of barrier at inlet locations to provide a smooth line along the top of the barrier.

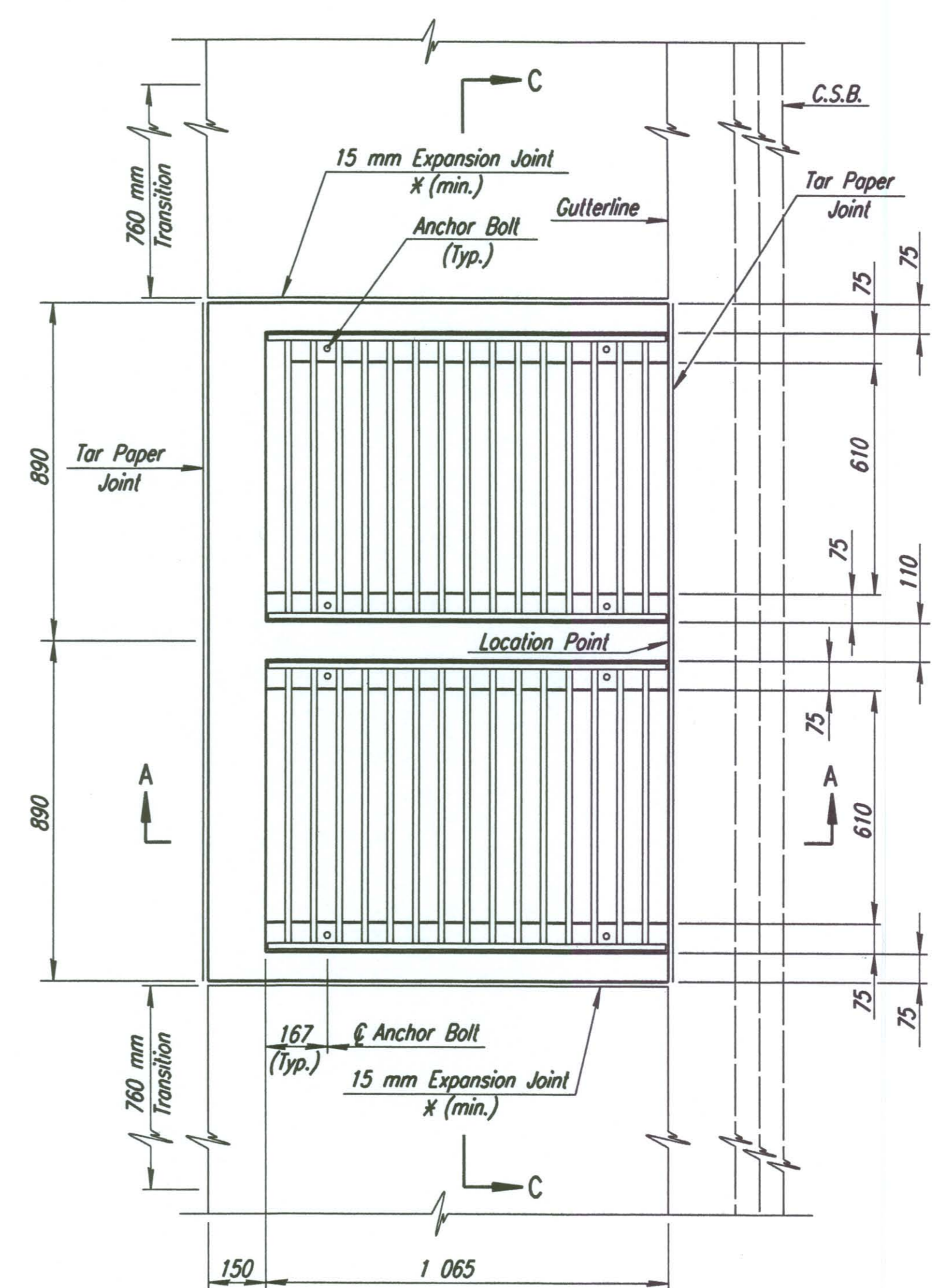

PLAN

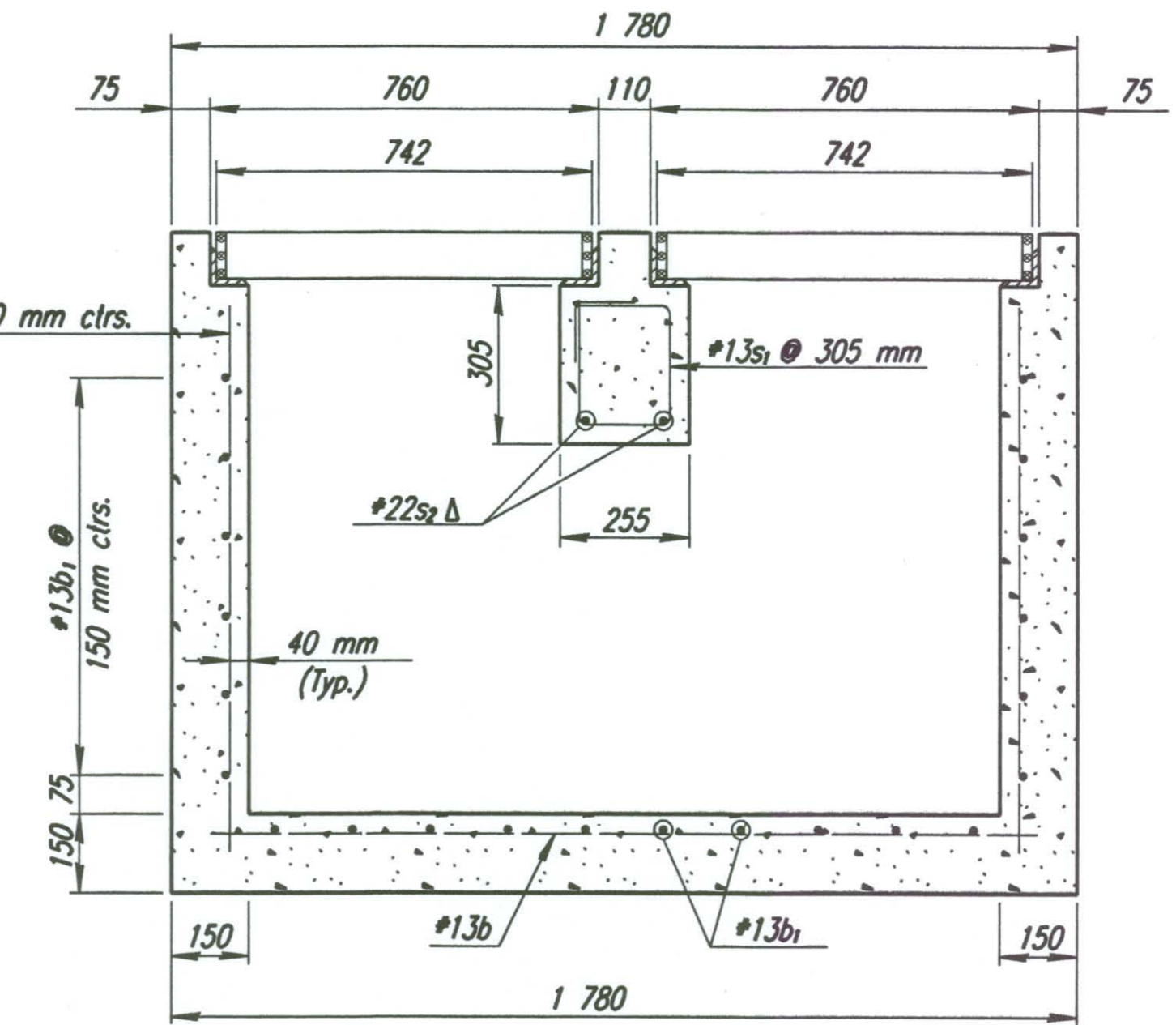

SECTION C-C

GUTTER INLET (SPECIAL)

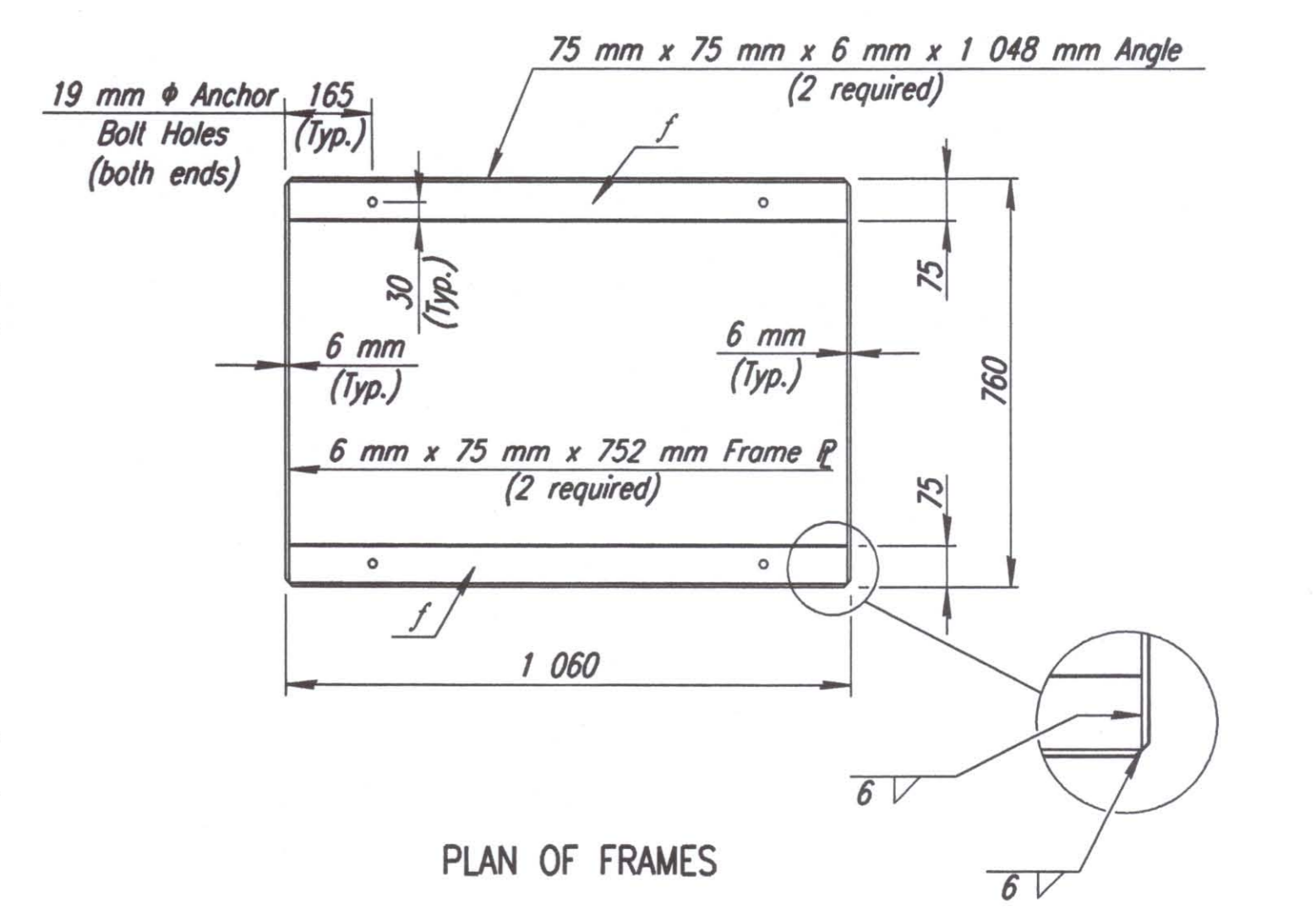

PLAN OF FRAMES

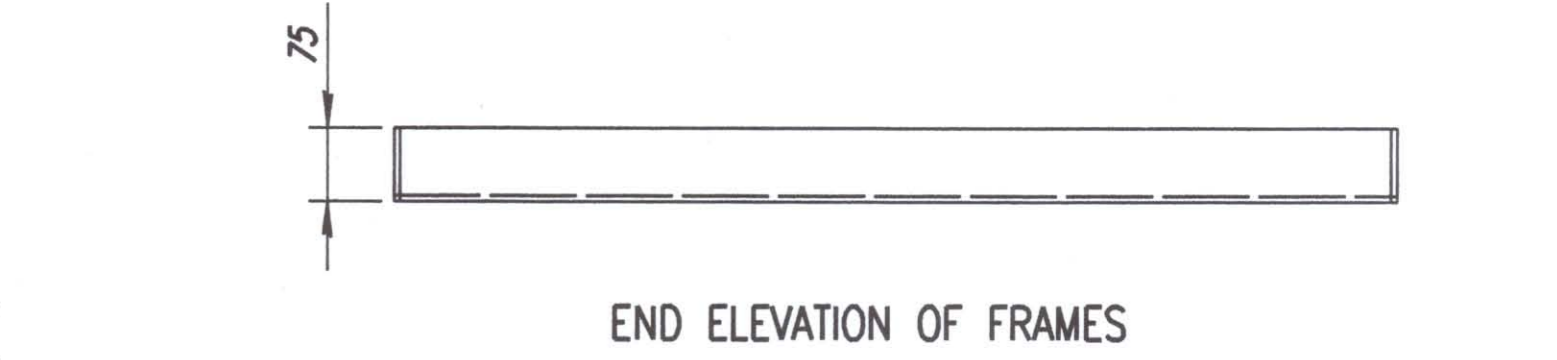

END ELEVATION OF FRAMES

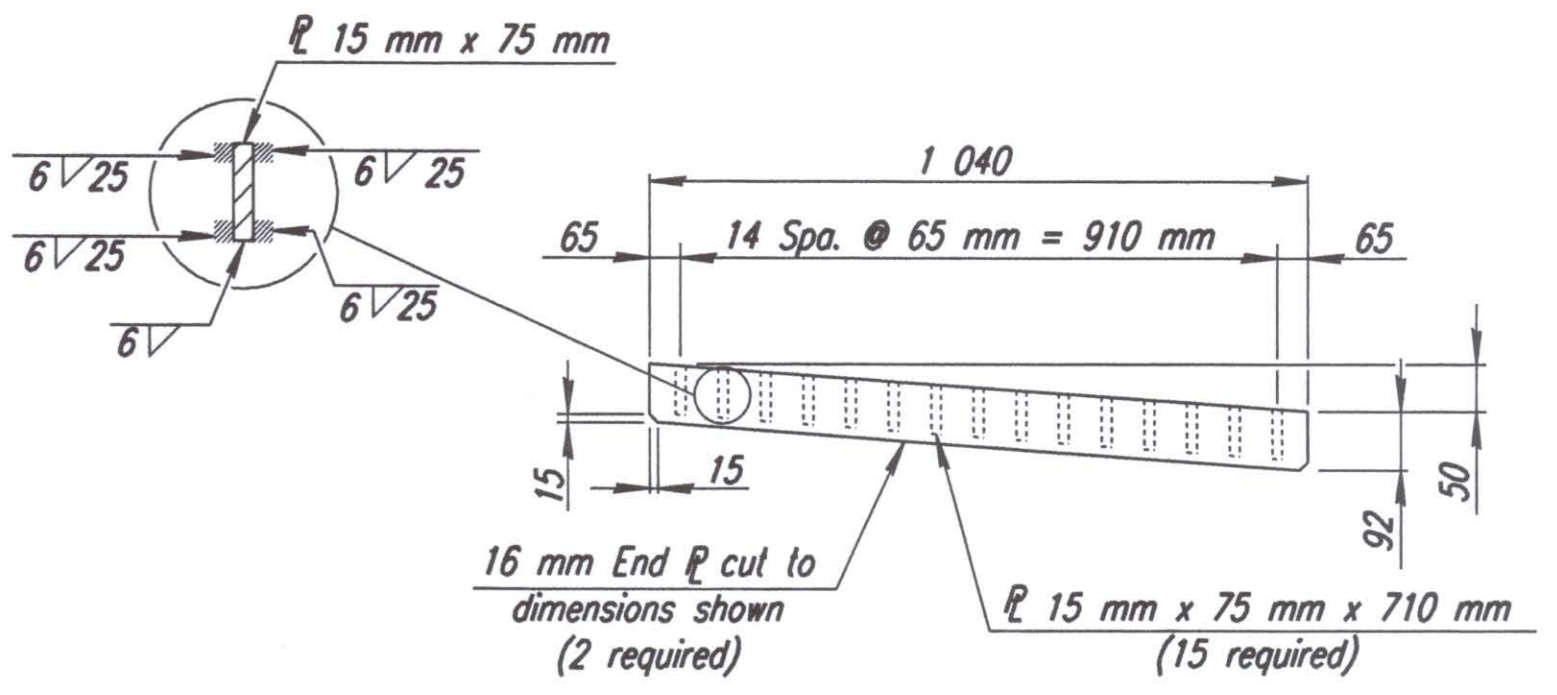

END ELEVATION OF GRATE

Welded structural steel grate and frame weight = 148 kg. Steel for grate and frame shall comply with A.S.T.M. A36M-96, A242M-93a, or A441M.

Note: To prevent grate from rocking on bearing angles, machine finish surfaces indicated thus "f". All materials for the grates shall be galvanized after fabrication.

GRATE AND FRAME DETAILS (TYPE G)

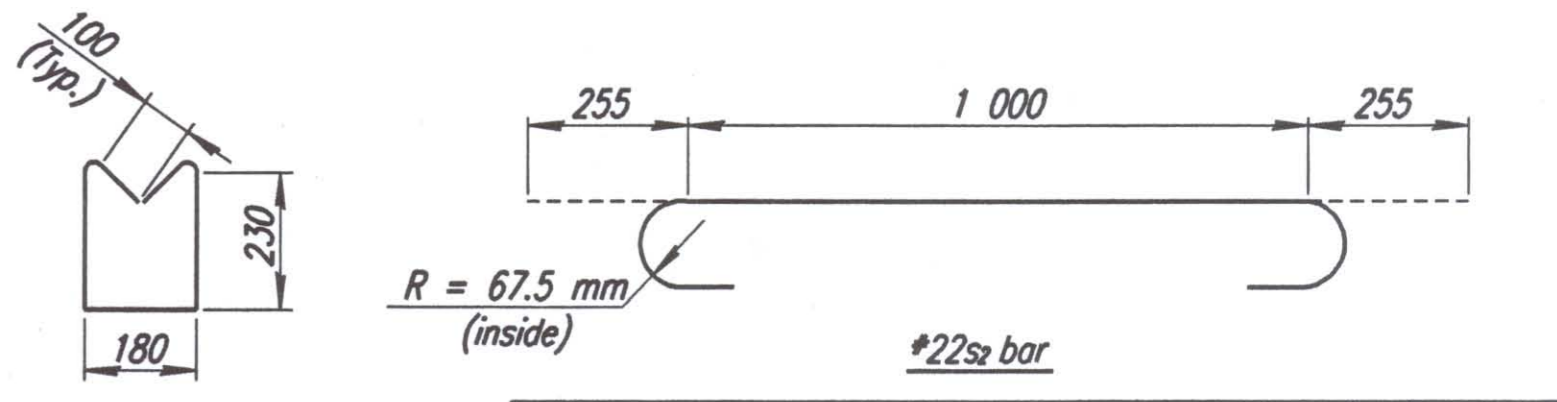

No.	Revisions	By	Date

CITY OF WICHITA

GUTTER INLET & GUTTER INLET (SPECIAL)

SEDGWICK COUNTY

Professional Engineering Consultants, P.A.
 303 S. TOPEKA • WICHITA, KANSAS 67202
 316-262-2691 • FAX 316-262-3003

Designed by	Checked by	RAS
Drawn by	Date	April, 2002
	Job No.	97362