

GENERAL NOTES

UNIT STRESSES: Class AAA Concrete; $f'_c = 28 \text{ MPa}$
Reinforcing Steel; $f_y = 420 \text{ MPa}$

CONCRETE: Class AAA Concrete shall be used throughout. Bevel all exposed edges with a 20 mm triangular moulding.

REINFORCING: All reinforcing shall conform to ASTM A615M-96, Grade 420. Welded Wire Fabric shall conform to ASTM A185M. All dimensions relative to reinforcing steel shall be to center-line of bar unless otherwise noted.

QUANTITIES: Wingwall Quantities include all quantities outside the neat lines of the box, excluding the hubguard.

APRON: A 125 mm concrete slab shall be constructed between the downstream wings in locations subject to scour only when specified on the plans or by the Engineer. Wire Reinforcing mesh shall be electrically welded and shall be composed of 150x150-MW10xMW10 welded wire fabric and shall be classified as kilograms of reinforcing.

FOUNDATION AND BACKFILL MATERIAL: Soils judged as high plasticity clays, fat clays, expansive clays, or organic clays are unsuitable for foundation and/or backfill material for wingwalls and will not be used. Where these conditions exist, Foundation Stabilization and/or Granular Backfill (Wingwalls) shall be used as determined by the Engineer. See "RCB Auxiliary Details" sheet for additional details.

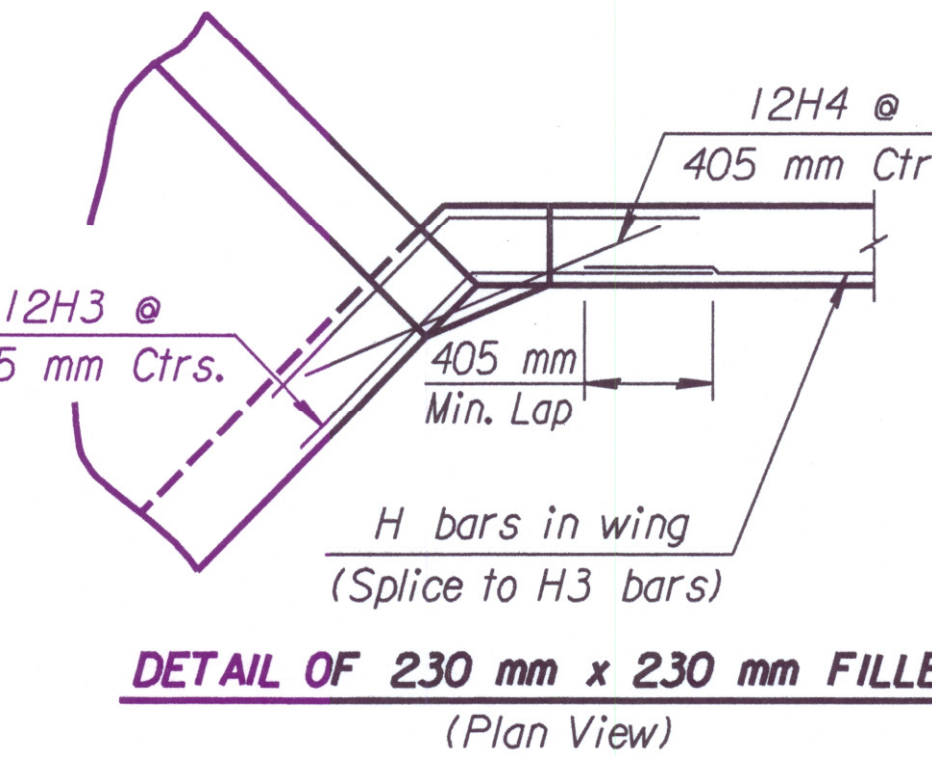
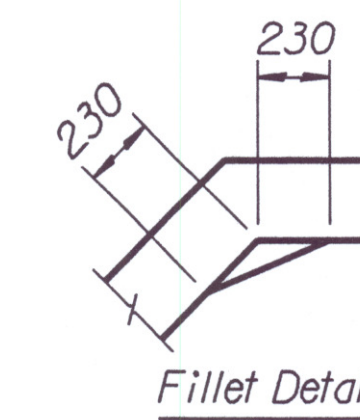

DETAIL OF 230 mm x 230 mm FILLET
(Plan View)

† **NOTE:** Const. Jt. may be used at Contractor's option when approved by the Engineer. DI bars or mesh may be spliced thus: Minimum overlap shall be 380 mm. No increase in quantities or cost shall be allowed when Contractor elects this option.

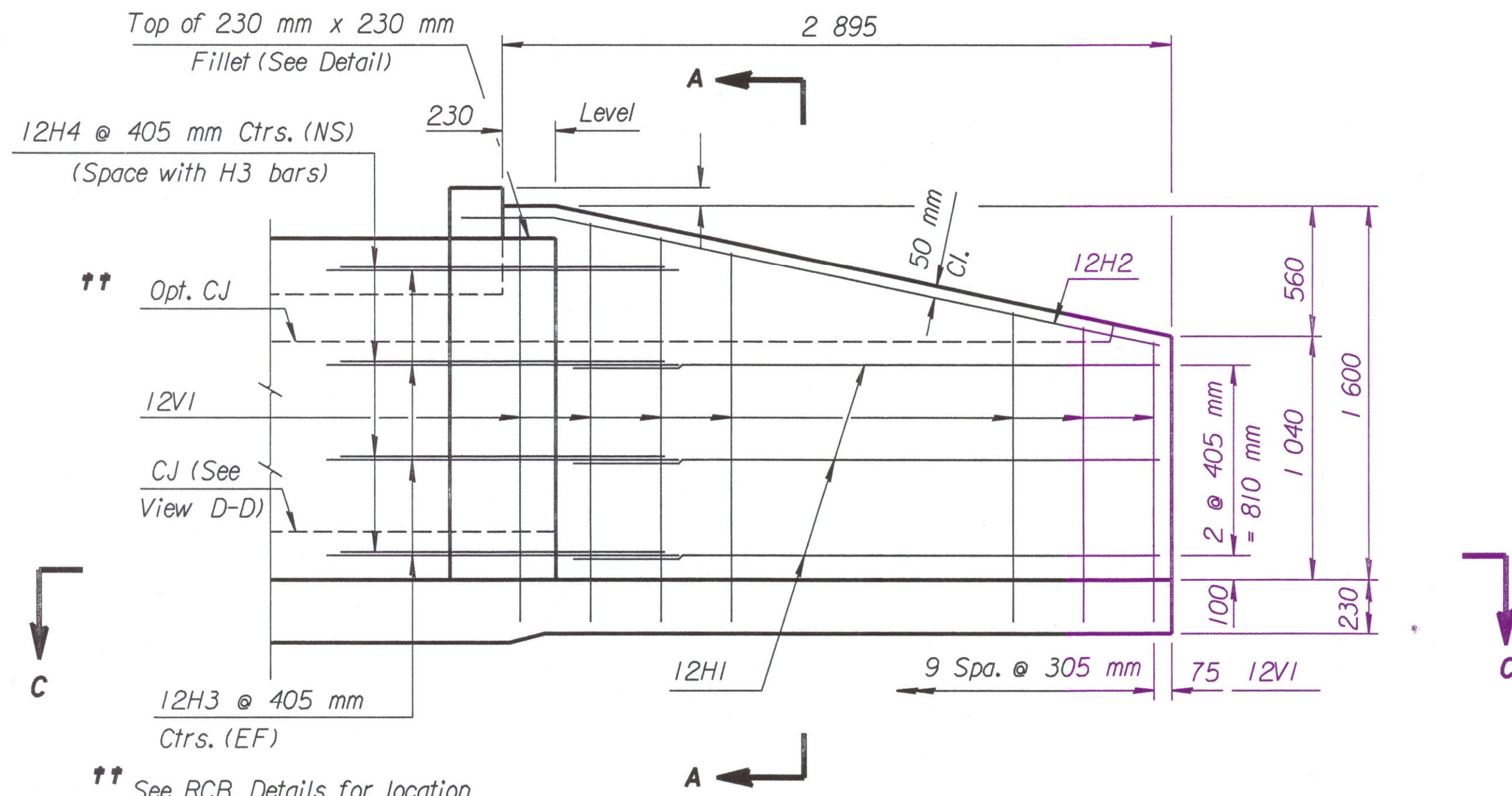

ELEVATION OF WINGWALL
(Backface Shown)

See "RCB Aux. Details" sheet for requirements of Wingwall Subbase.

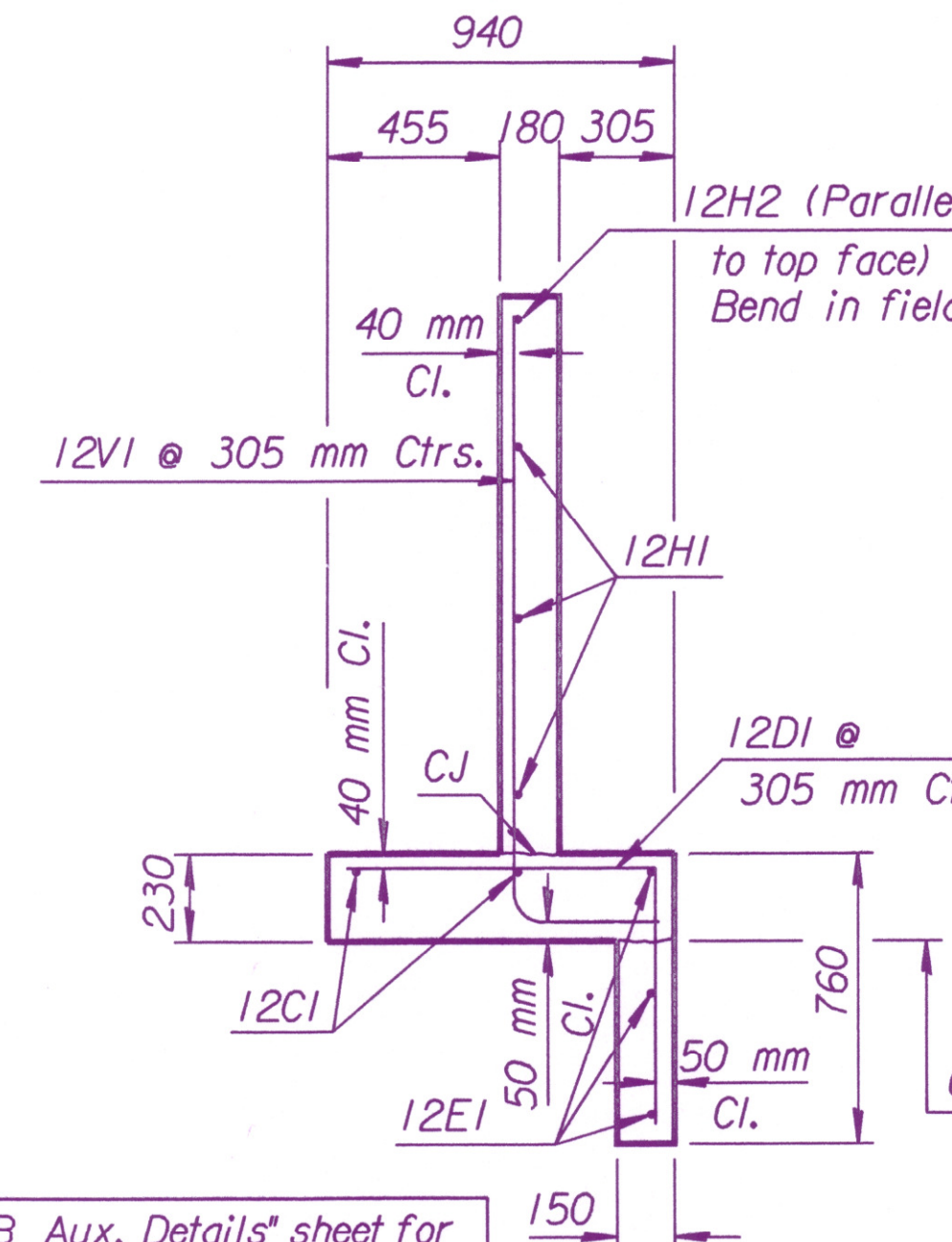

SECTION A-A

NOTE:
EF = Each Face
NS = Near Side
FS = Far Side
CJ = Const. Joint

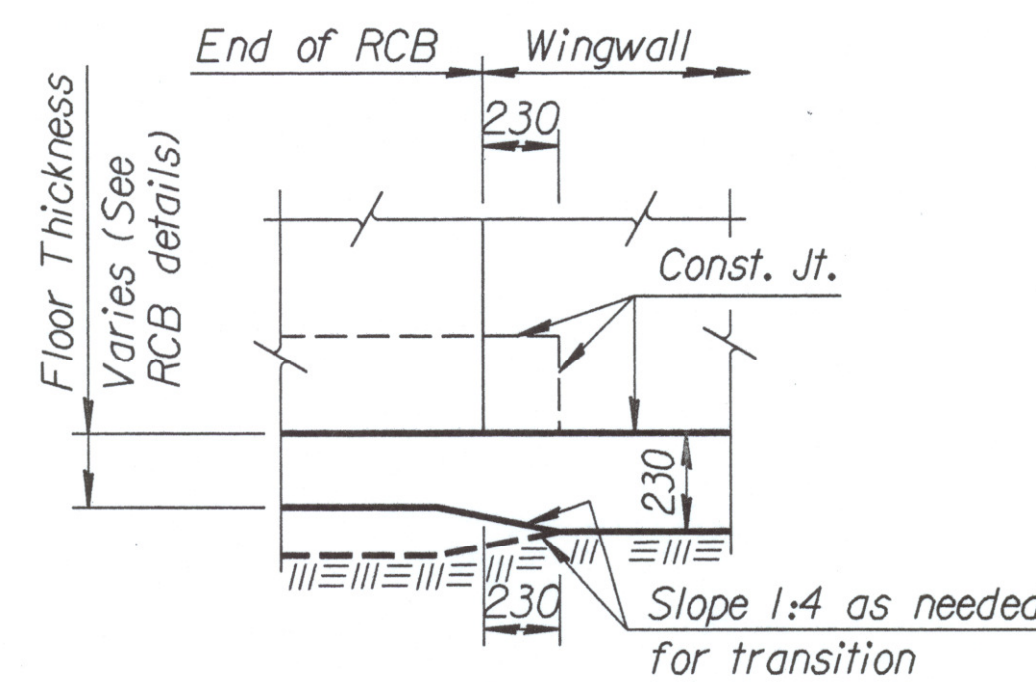

VIEW D-D

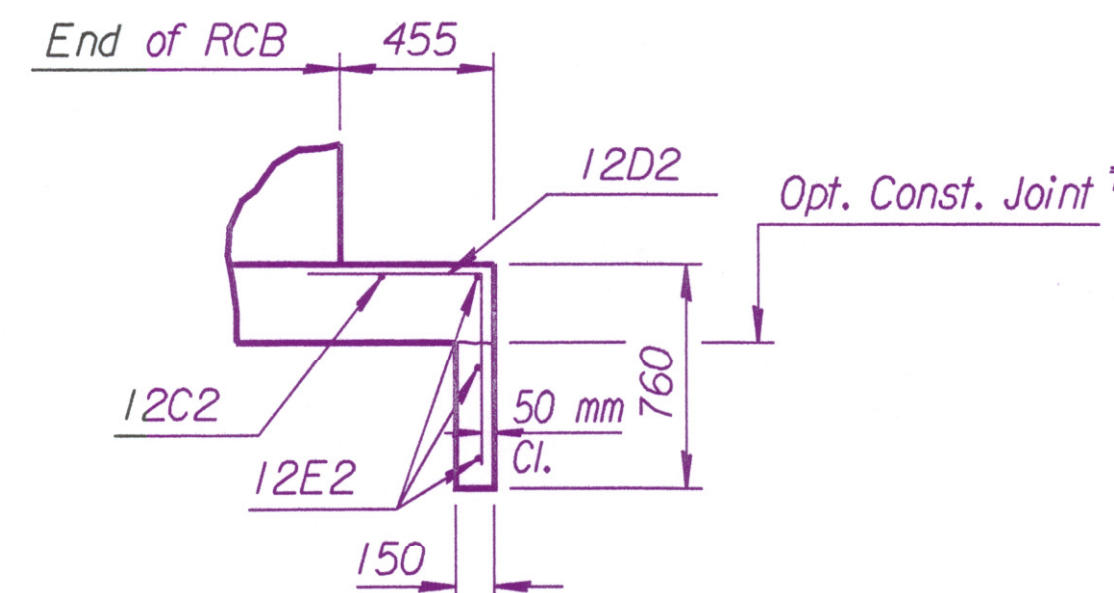

SECTION E-E

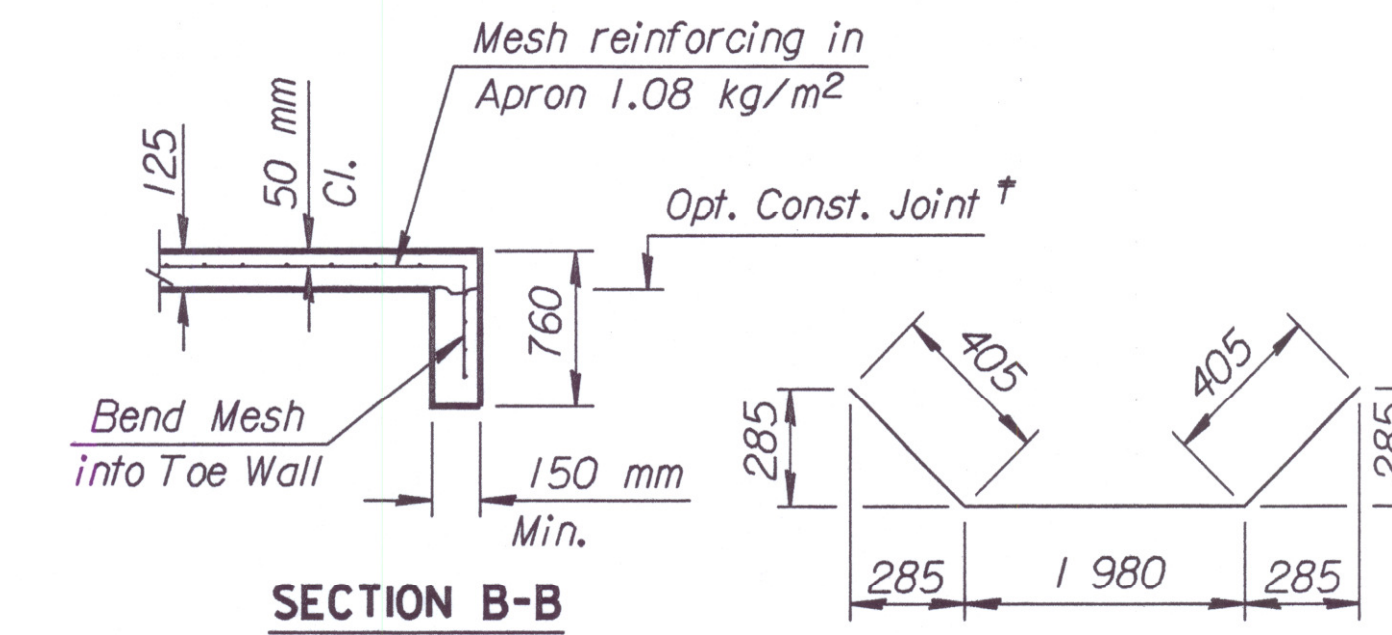

SECTION B-B

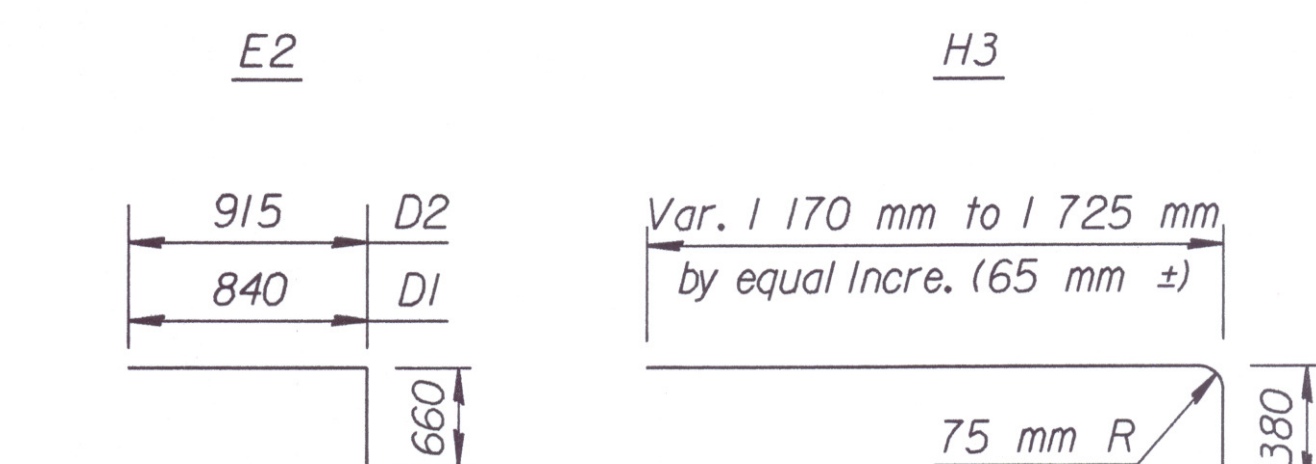

BENDING DIAGRAM

(All dimensions are out to out of bars.)

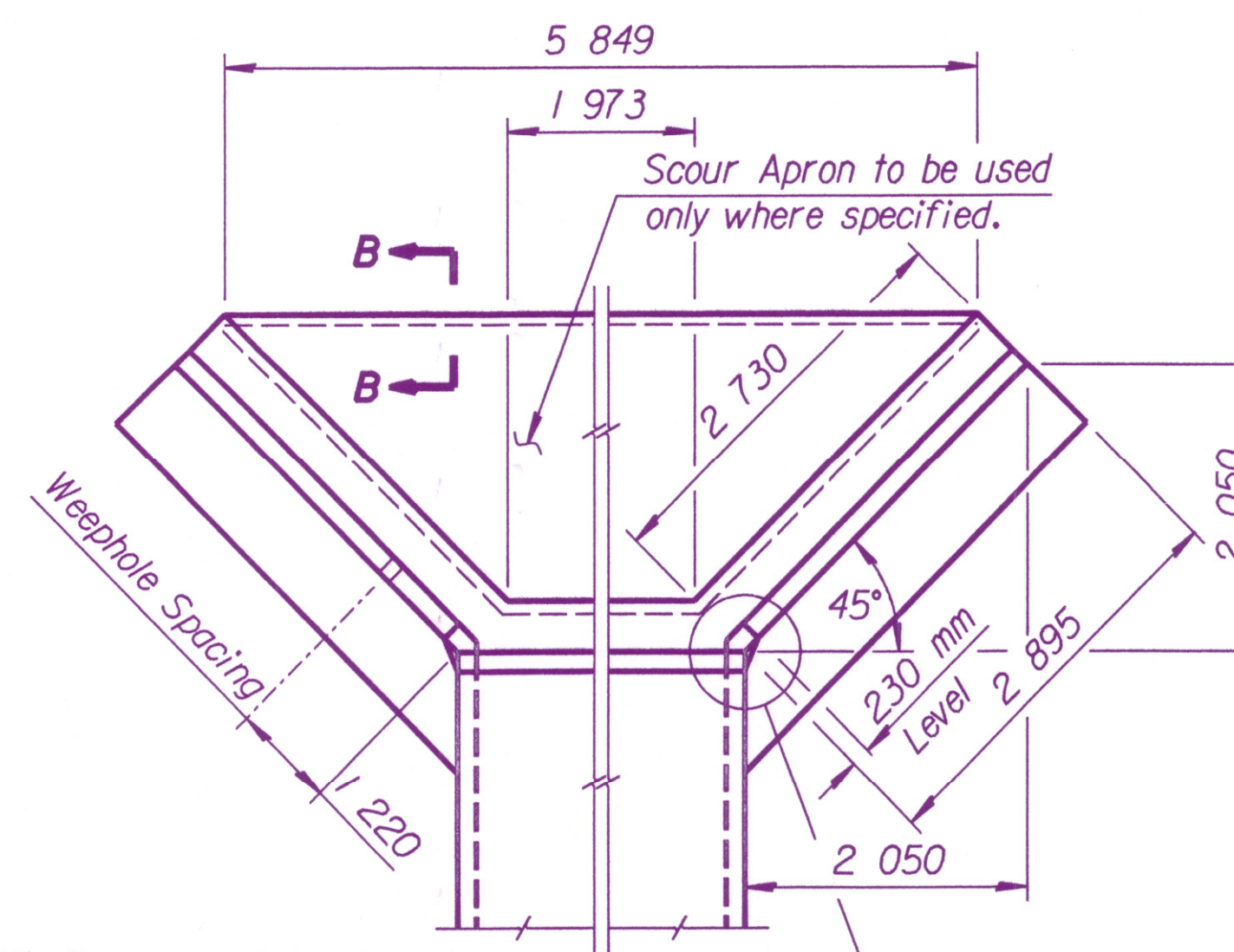

WING DIMENSIONS FOR NORMAL BOX

(1:3.5 Embankment Slope)

NOTE: Space weepholes to clear reinforcing steel. See "RCB Aux. Details" sheet for additional weephole details.

Quantities listed below are included in the Summary of Quantities shown on the RCB details.

WINGWALL QUANTITIES (One End Only)	
Class AAA Concrete:	
Wingwalls (Left or Right)	3.57 m ³
Apron (Right)	1.5 m ³
Reinforcing Steel (Wingwall Lt. or Rt.)	167.4 kg
Welded Wire Fabric (Apron Rt.)	12.2 kg

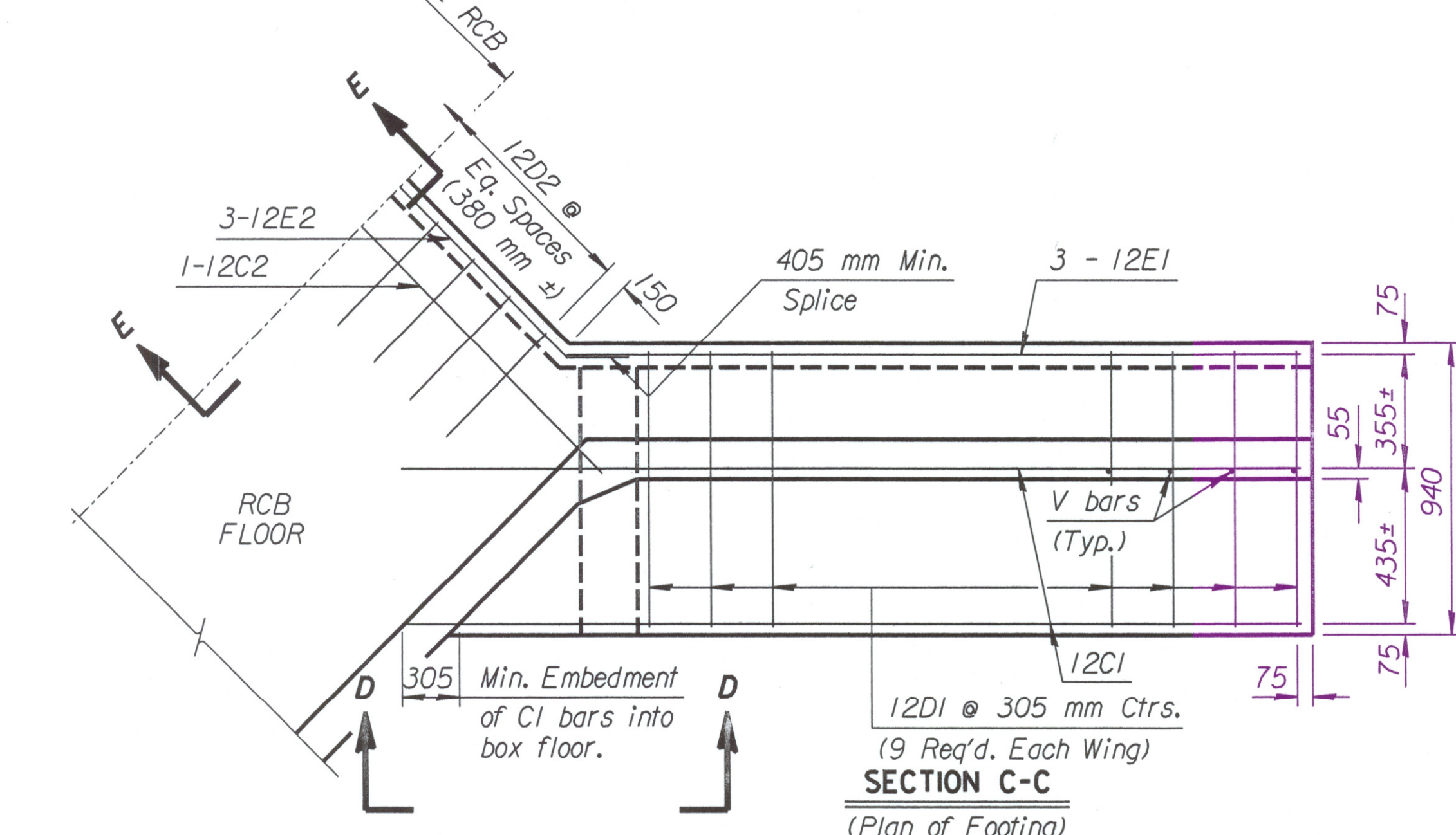

SECTION C-C
(Plan of Footing)

NOTE: Reinforcing Bar List is for both wings at one end of box only.

0° Skew	Reinforcing Bar List											
	No.	12C1	12DI	12E1	12C2	12D2	12E2	12V1	12H1	12H2	12H3	12H4
No.	4	18*	6	1	6*	3*	20	6	2	16*	8	
Length	3 530	1 500	2 665	2 430	1 575	2 790	*	2 540	3 100	1 520	1 065	

* See Bending Diagram

ORIG. FROM BR. NO.	PROJ.	DESIGN	DATE	DATE	DATE	DATE	DATE
DESIGN							
DETAIL							
TRACING							
RETRACED							

NO.	DATE	REVISIONS	BY	APP'D

KANSAS DEPARTMENT OF TRANSPORTATION
Sta. 5+311.000
FLARED WINGWALLS
1.22 m RISE (0° SKEW)

BR
FHWA APPROVAL 6-5-91 APP'D KENNETH F. HURST
DESIGNED QUANTITIES TRACED
DESIGN CK. DETAIL CK. QUAN. CK. TRACE CK.