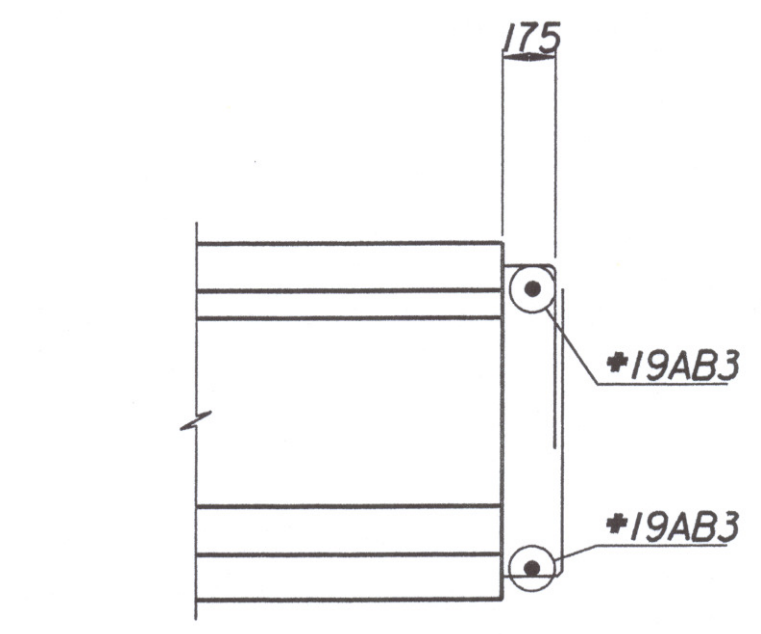
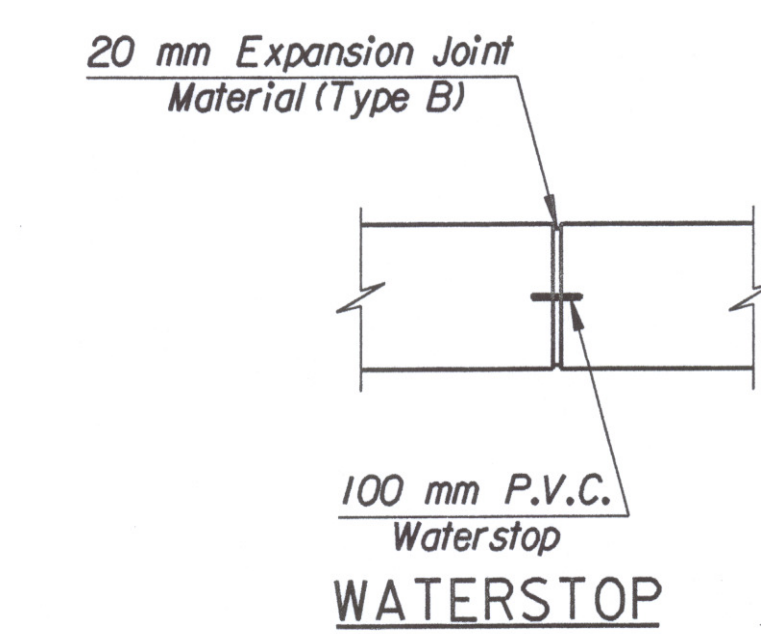
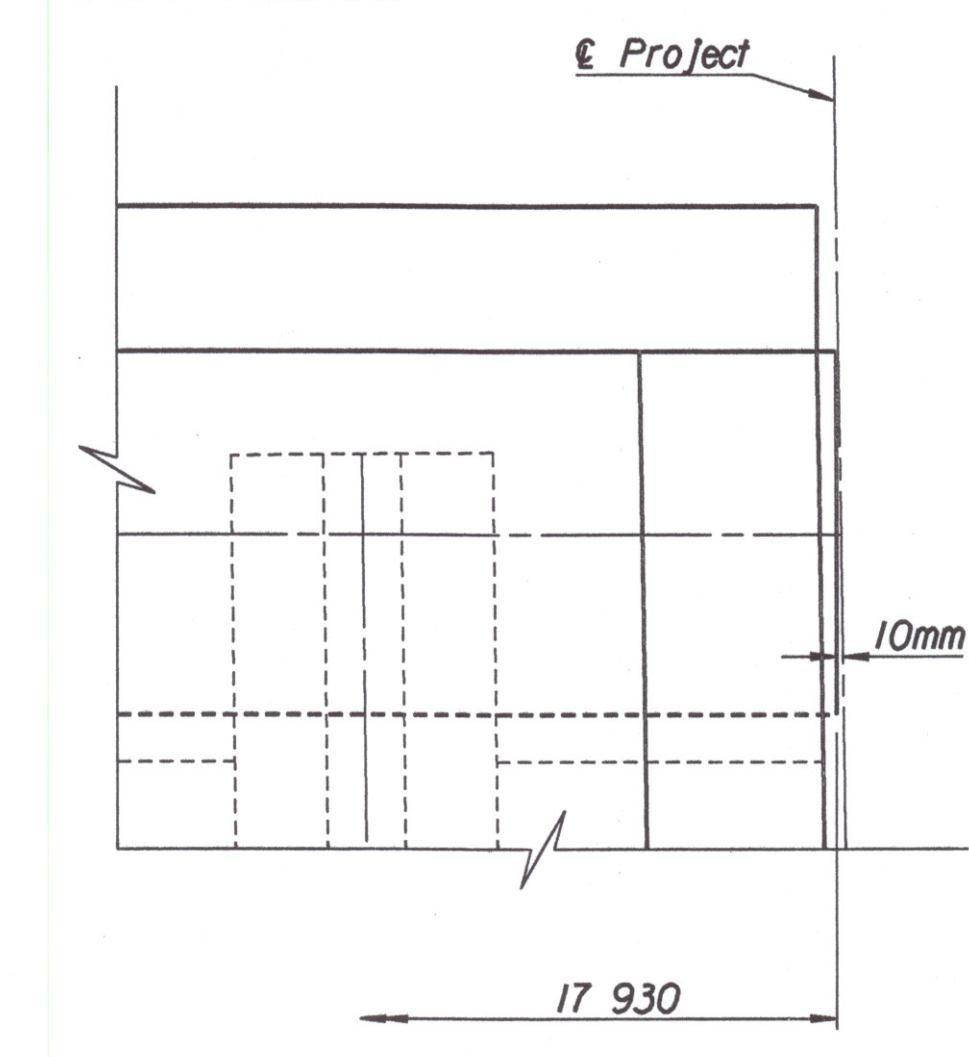
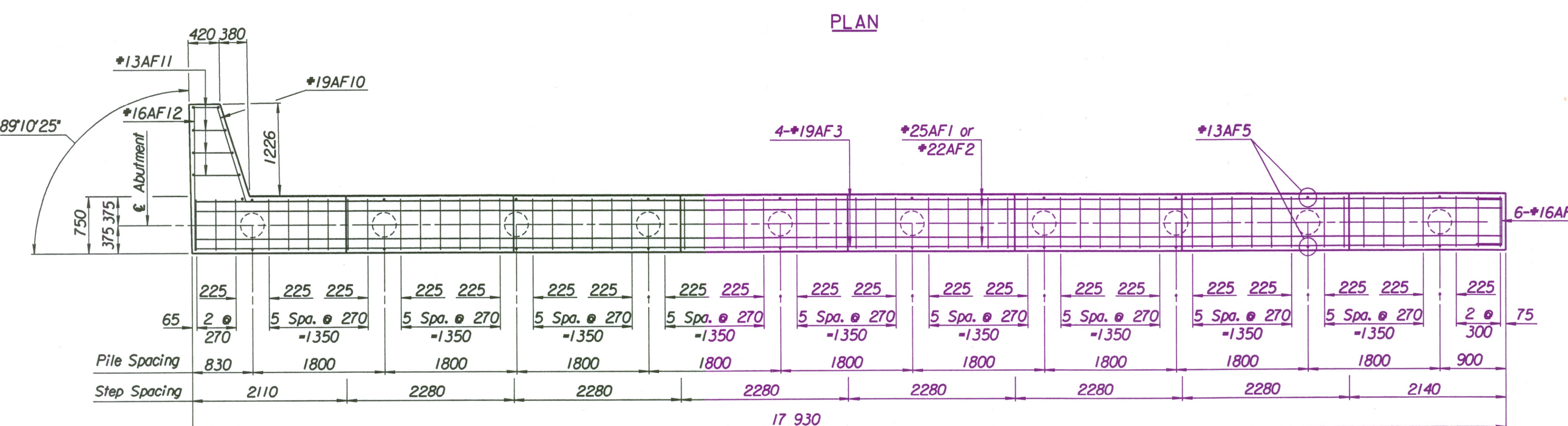

TABLE OF ELEVATIONS

Location	Elevation
Elev. A	402.375
Elev. C	402.424
Elev. E	400.995
Elev. F	401.041
Elev. G	401.087
Elev. H	401.133
Elev. I	401.179
Elev. J	401.224
Elev. K	401.270
Elev. L	401.316
Elev. U	399.850
Elev. V	402.721
Elev. X	402.768



Abutment Pile Loadings (kN)

Group	Actual	Allowable
Group 1 Loading	403	440

No.	Revisions	By	Date
CITY OF WICHITA			
BR. NO. 54-87-19.3(494) W.B.		STA. 16+011.650	
WEST KELLOGG WESTBOUND MAINLINE OVER COWSKIN CREEK			
ABUTMENT NO. 2 DETAILS			
SEDGWICK COUNTY			
Professional Engineering Consultants, P.A.			
303 S. TOPEKA - WICHITA, KANSAS 67202 316-262-2691 • FAX 316-262-3003			
Designed by	RAS	Checked by	RAS
Drawn by	DRP	Date	April, 2002
		Job No.	97362

Drawn By: drp
 Plotted By: drp 3-25-2002
 I:/1997/97362/001/bridge/cowskin/Mainline/abmt2wbmt.dgn