

STATE	PROJECT NO.	YEAR	SHEET NO.	TOTAL SHEETS
KANSAS	54-87 K-6657-01	2002	520	1122

**GENERAL NOTES**

Fabricate the precast prestressed beams in accordance with the KDOT Specifications. Submit shop drawings in accordance with the KDOT Specifications except nine sets are required.

Use air entrained concrete. The KDOT Materials Section shall approve the mix design. Unless otherwise shown on the plans,  $f'c = 35$  MPa and  $f'c$  at release = 30 MPa.

Use reinforcing steel conforming to the requirements of ASTM A615M-96, Grade 420. All reinforcing shall be epoxy-coated.

Use 13 mm nominal diameter, uncoated, seven-wire, low relaxation prestressing tendons conforming to the requirements of ASTM A416, Grade 1860.

Use coil ties and bolts having an ultimate strength 50% in excess of the manufacturer's safe load. The Engineer shall approve the coil ties. Coat coil ties that touch prestressing tendons with an approved epoxy coating. Show coil tie details on the shop drawings. Coil ties and bolts shall be subsidiary to the bid item, "Prestressed Concrete Beams".

Use elastomeric bearing pads conforming to the KDOT Specifications. Bearing pads and Type B expansion joint material shall be subsidiary to the bid item, "Prestressed Concrete Beams".

The beam lengths shown on the design plans are net lengths measured horizontally along the beam centerline. The beam manufacturer shall make necessary allowances for grade, and for shortening due to elastic shortening, creep and shrinkage.

The beams shall reasonably conform to the lines and dimensions shown on the design plans and be within the tolerances specified in the latest publication of AASHTO, "Tentative Standards for Prestressed Piles, Slab, I-Beams and Box Bridges and an Interim Manual for Inspection of Such Construction", except as modified by this sheet or the KDOT Specifications.

Bevel all exposed edges of beams except the tops and ends with a 20 mm triangular molding or round the edges to a 20 mm radius. Round the angle of intersection between the web and the flanges.

Apply an initial force of 5 to 10 kN to each strand to take up any slack in the cables. Unless otherwise noted on the plans, apply a force of 138 kN to each strand. Stress harped strands to a magnitude such that they are tensioned to 138 kN after they are in position.

Strike off level and apply a wire brush or stiff broom finish to the tops of the beams. Apply the finish transverse to the length of the beam. (Note: When using precast panels for deck construction, the outside 125 mm on each side of the top flange shall be finished smooth with a steel trowel.) At approximately the time of initial set, brush the top of the beam transversely with a coarse wire brush to remove all laitance.

Fill trapped air holes and surface voids on the exterior face of the exterior beams with an approved concrete masonry coating. This work shall conform to KDOT Specifications. This work shall be subsidiary to the bid item, "Prestressed Concrete Beams".

Detension strands in a sequence which minimizes lateral eccentricity. Show the method and sequence of strand release on the shop drawings. Use extreme care when lifting, handling, storing and transporting beams. Use the lifting system shown or an alternate system approved by the Engineer. Keep the beam in an upright position at all times. Support the beam on bearing points positioned directly below the designated lifting points or designated bearing points.

Do not place the bridge slab before the beams are 28 days old. Pour diaphragms as detailed in the bridge plans.

Stencil with paint the following information on the webs approximately 1.5 m from one end of the beam: date of concrete placement, date of strand release, and beam mark.

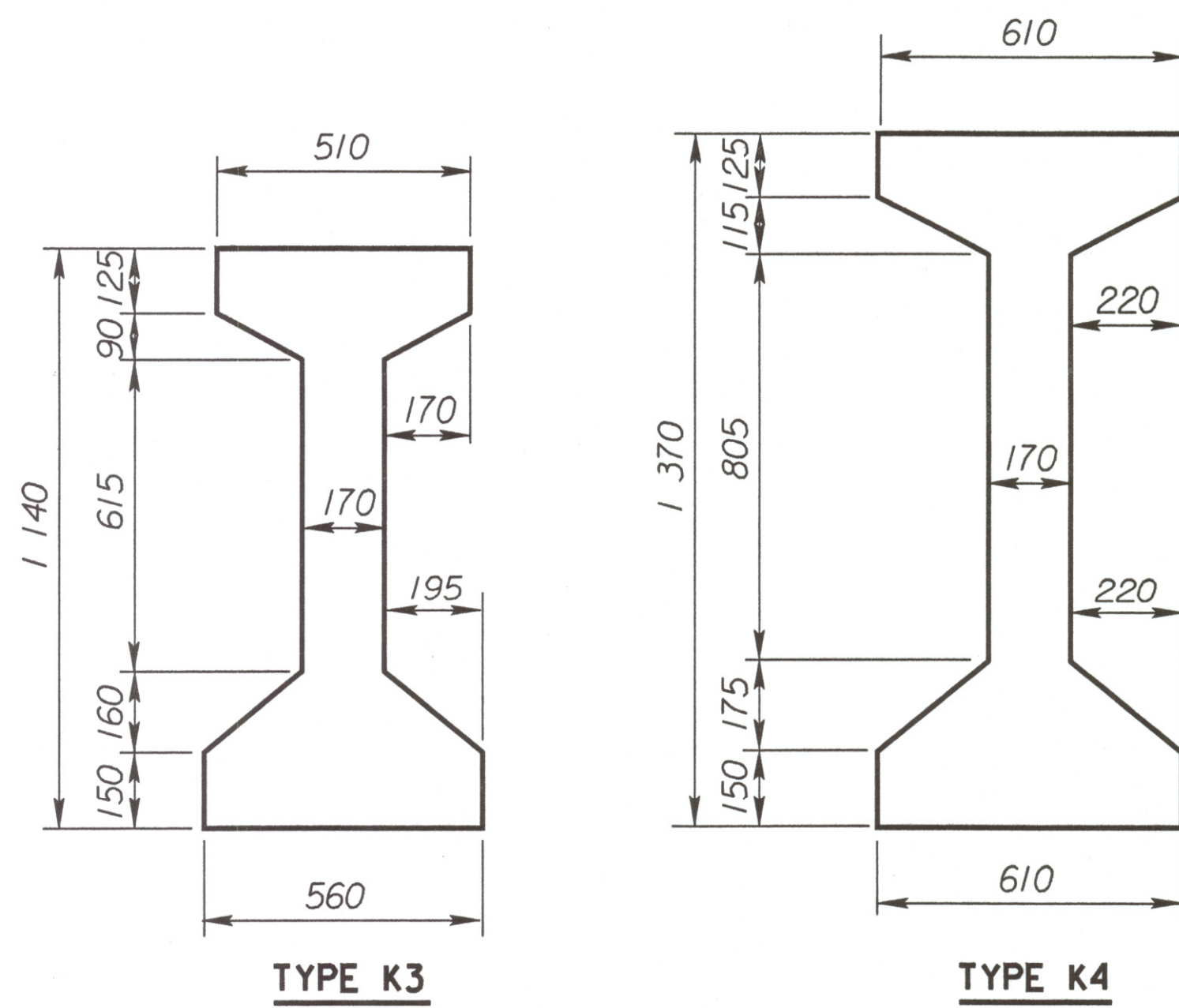

12 mm x 375 mm x 560 mm (K4)  
12 mm x 375 mm x 510 mm (K3)  
(Flush with bottom of beam.)

**ELEVATION**

Note: Stud welding will be in accordance with the latest edition of AWS D1.1.

Use plate conforming to the requirements of ASTM A709M Grade 250. The stud anchors will be made of material as specified for Shear Connector Studs in the KDOT Specifications.

The exposed surface of the bearing plates shall be galvanized.

All work and material to install the bearing plates shall be subsidiary to the bid item "Prestressed Concrete Beam".

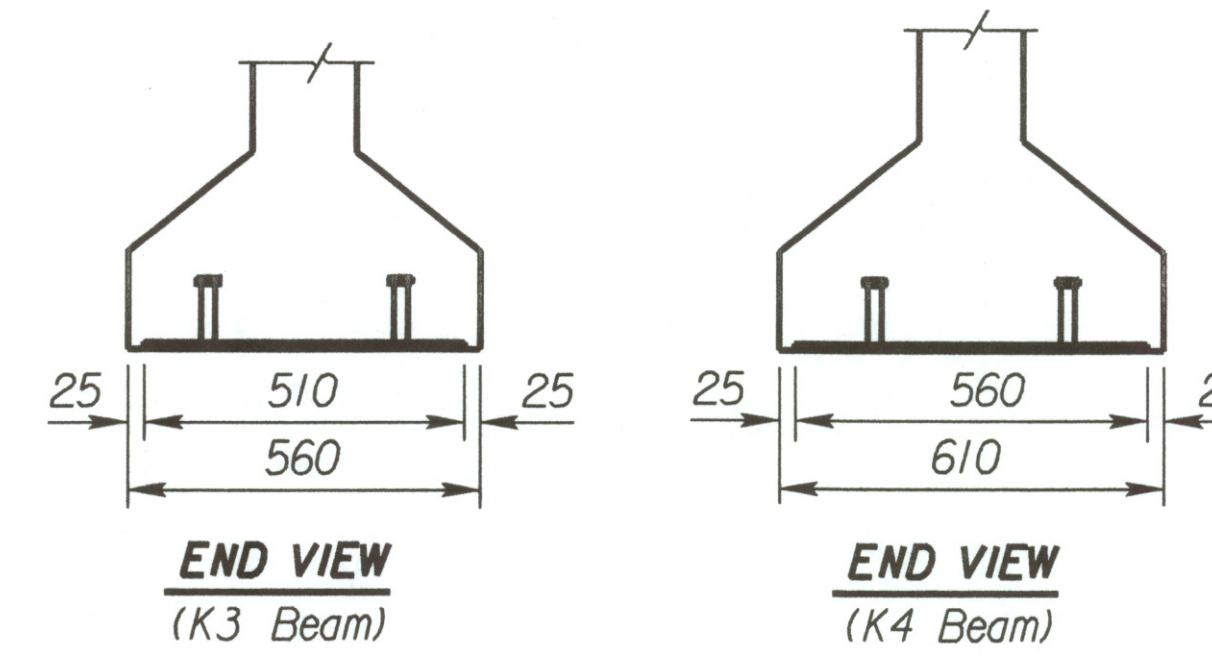

**END VIEW**  
(K3 Beam)

**END VIEW**  
(K4 Beam)

Area	341 300 mm <sup>2</sup>	Area	417 700 mm <sup>2</sup>
IcG	52 858x10 <sup>6</sup> mm <sup>4</sup>	IcG	97 912x10 <sup>6</sup> mm <sup>4</sup>
Y Bot	533 mm	Y Bot	658 mm
Vol./Surf. Area	91 mm	Vol./Surf. Area	94 mm
Mass/m	819 kg	Mass/m	1002 kg

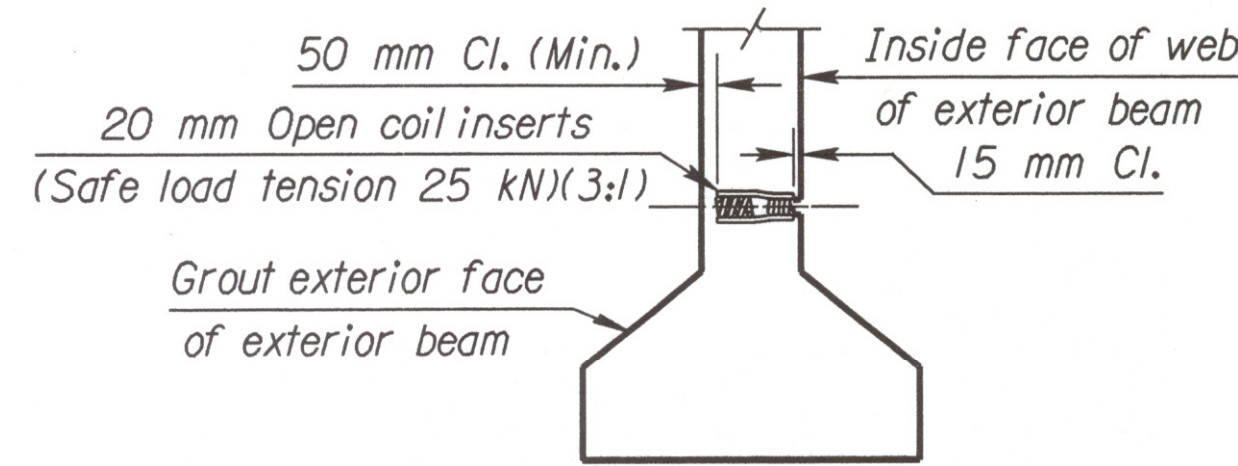

**DETAIL OF COIL INSERT**

(See Beam Detail sheet for locations)

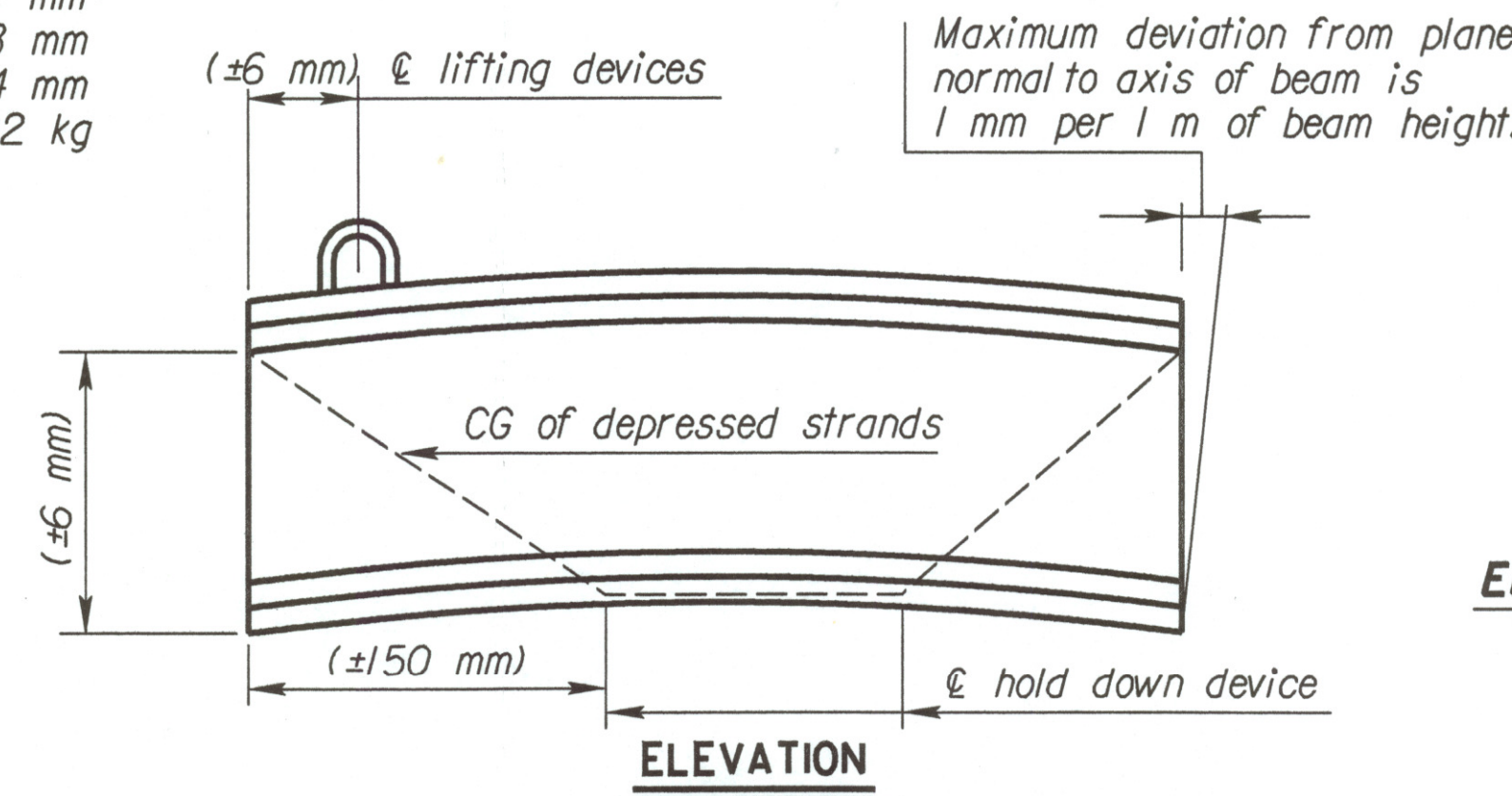

**ELEVATION**

Note: Dimensions shown in parentheses are tolerances only.

CG = Center of Gravity

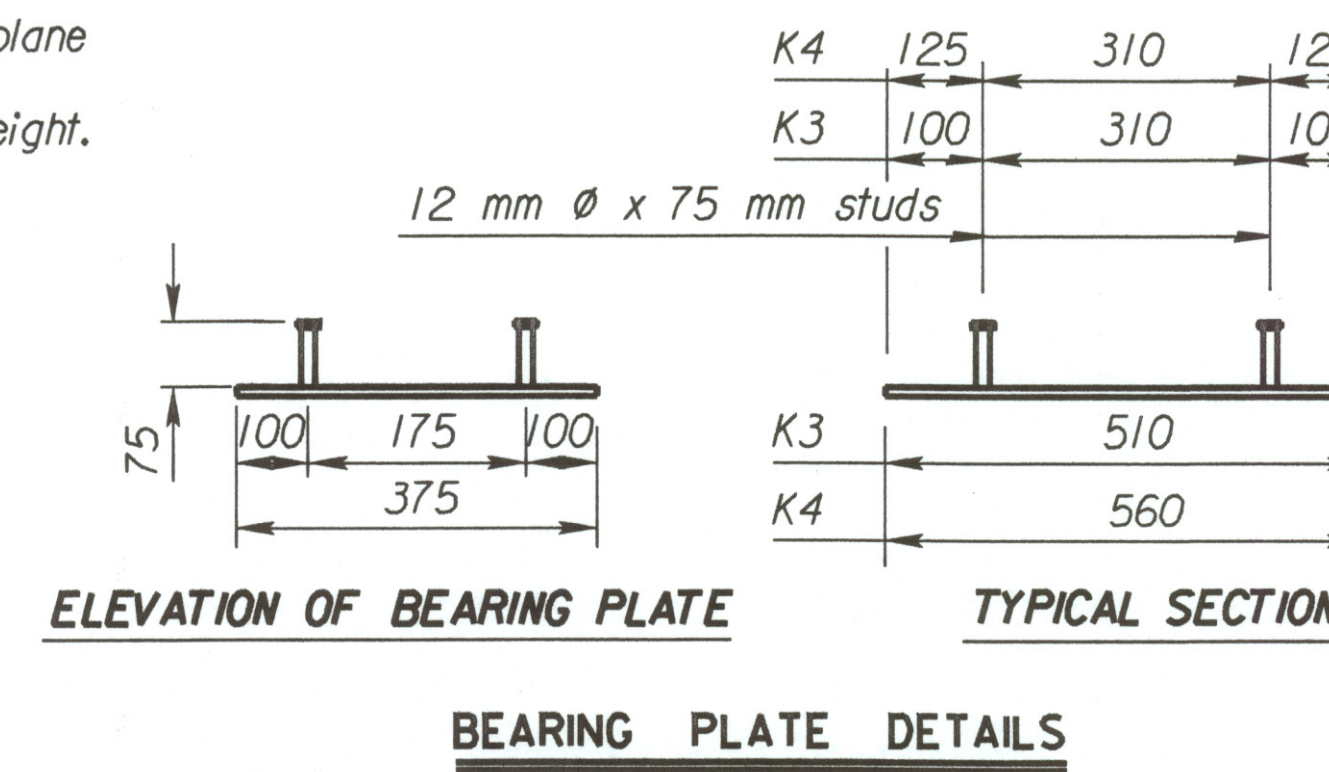

**ELEVATION OF BEARING PLATE**

**TYPICAL SECTION**

**BEARING PLATE DETAILS**

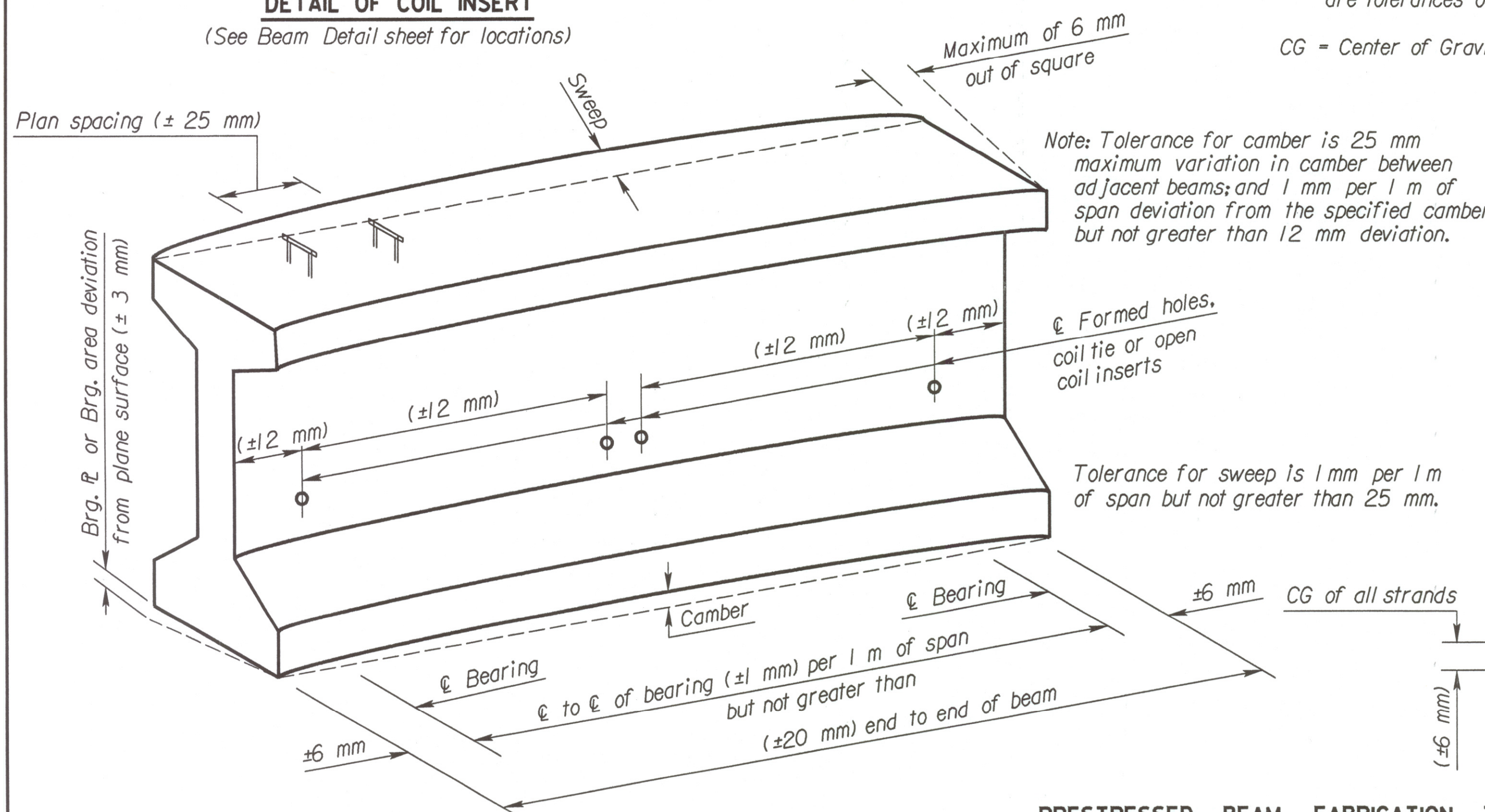

**PRESTRESSED BEAM FABRICATION TOLERANCES**

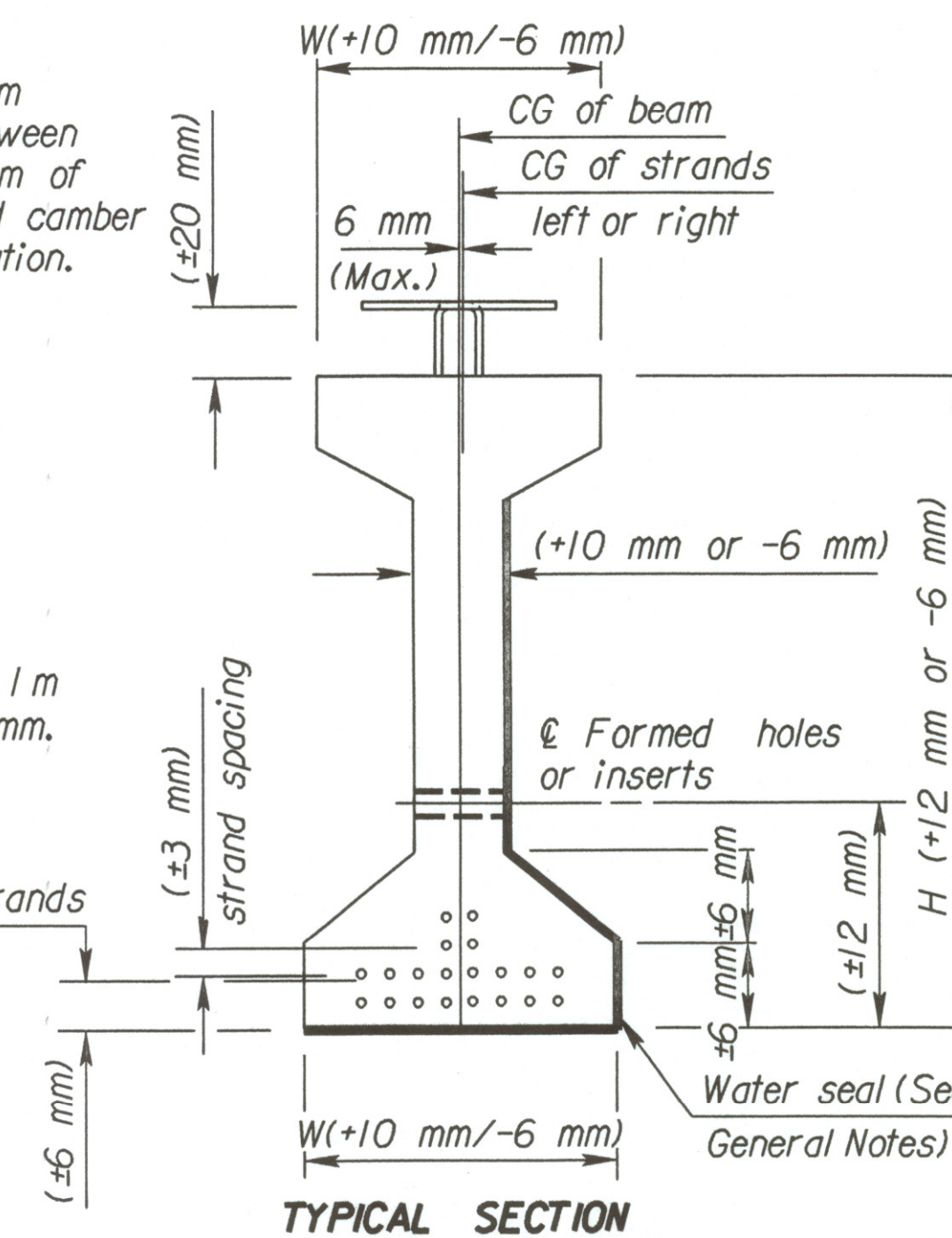

**TYPICAL SECTION**

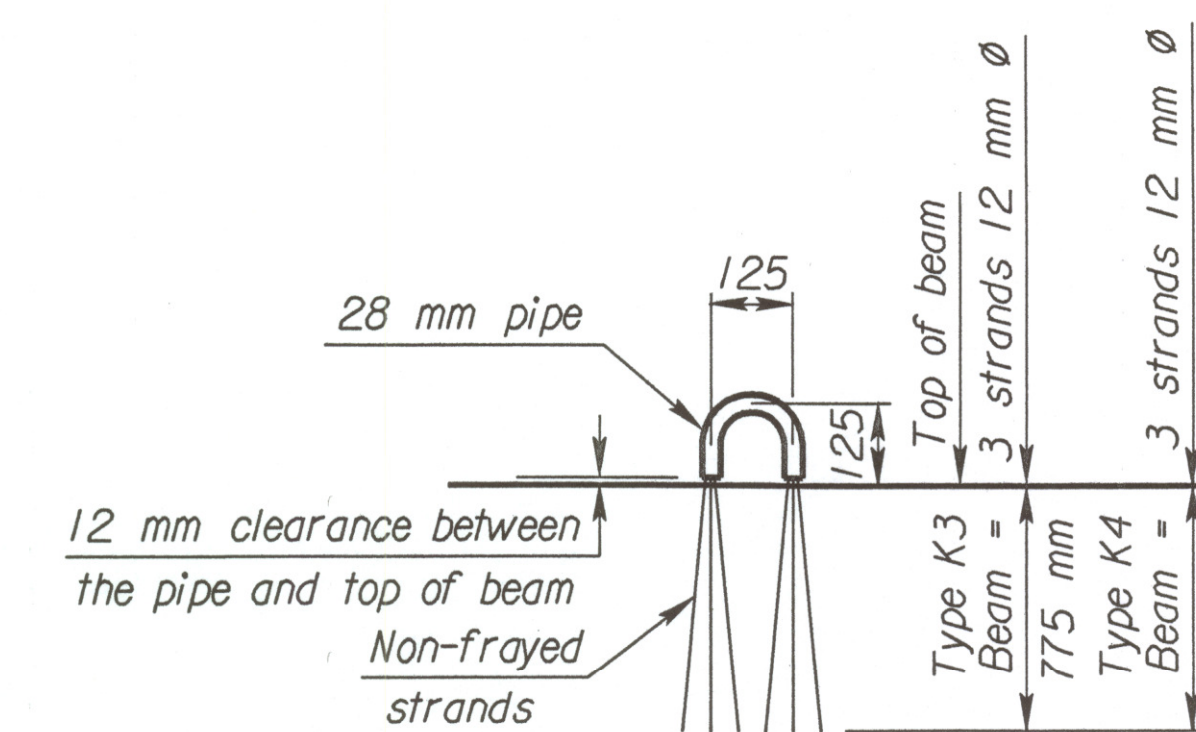

NO.	DATE	REVISIONS	BY	APP'D
7	6-23-97	Added precast panel note	LRR	KFH
6	3-28-97	Delete optional brg. pl.	LRR	KFH
5	6-5-96	Remove btm flg open coil tie insert	LRR	KFH
4	3-27-96	ASTM 615M-96 changes	LRR	KFH

**KANSAS DEPARTMENT OF TRANSPORTATION**

**STANDARD PRESTRESSED CONCRETE BEAM DETAILS**

BR300 SI

DESIGNED	DETAILED	CHK'D	APP'D
DESIGN CR.	DETAIL CR.	LRR/QUAN. CR.	KENNETH F. HURST

Plotted By : drp  
 Plot File : i:\1997\97362\001\bridge\cawskin\mainline\br300si.dgn  
 Plot Date : 3-25-2002  
 Std. Base File : /usr2/stand/si/br300si.dgn  
 Server File : /usr  
 Server : witch  
 View: PLOT1