

GENERAL NOTES:

- THIS SHEET IS INTENDED TO PROVIDE GUIDELINES AS TO WHAT TYPES OF BMP'S WILL BE INSTALLED DURING THE CONSTRUCTION PROCESS. CONTRACTORS ARE EXPECTED TO BID PROJECTS ACCORDINGLY.
- BMP'S MUST BE MAINTAINED BY THE CONTRACTOR THROUGHOUT THE CONSTRUCTION PROCESS.
- IF THE PROJECT WILL DISTURB 5 ACRES OR MORE, A FEDERAL/STATE NPDES STORMWATER PERMIT IS REQUIRED. A DETAILED STORMWATER POLLUTION PREVENTION PLAN, IS REQUIRED. THE BMP'S SHOWN ON THIS SHEET ARE CONSIDERED TO BE THE MINIMUM TO BE SHOWN IN THE POLLUTION PREVENTION PLAN.
- FOR PROJECTS DISTURBING LESS THAN 5 ACRES, CONTRACTORS ARE ENCOURAGED TO PREPARE STORMWATER POLLUTION PREVENTION PLANS PRIOR TO CONSTRUCTION.
- FAILURE TO USE AND MAINTAIN BMP'S IS A VIOLATION OF SECTION 16.32 OF THE CITY CODE AND WILL SUBJECT THE CONTRACTOR TO THE PENALTIES PROVIDED FOR THEREIN.
- THE APPLICATION OF BMP'S SHOWN ON THIS SHEET IS FOR SITUATIONS NORMALLY ENCOUNTERED. FROM TIME TO TIME, SITUATIONS WILL ARISE THAT MAY REQUIRE A DIFFERENT BMP OTHER THAN THOSE SHOWN. BMP'S, OTHER THAN THOSE SHOWN, MAY BE UTILIZED AS LONG AS THEY ARE EFFECTIVE AND MAINTAINED.

NOTE: SILT FENCE OR HAYBALE BMP BARRIERS WILL BE PAID FOR BY THE LINEAR METER AT THE UNIT PRICE BID FOR "TEMPORARY SLOPE BARRIER".

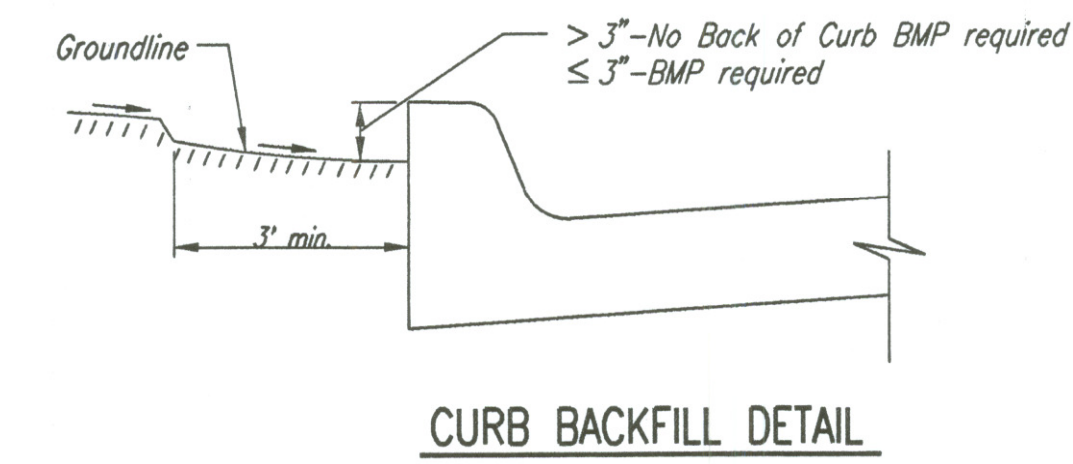

CURB BACKFILL DETAIL

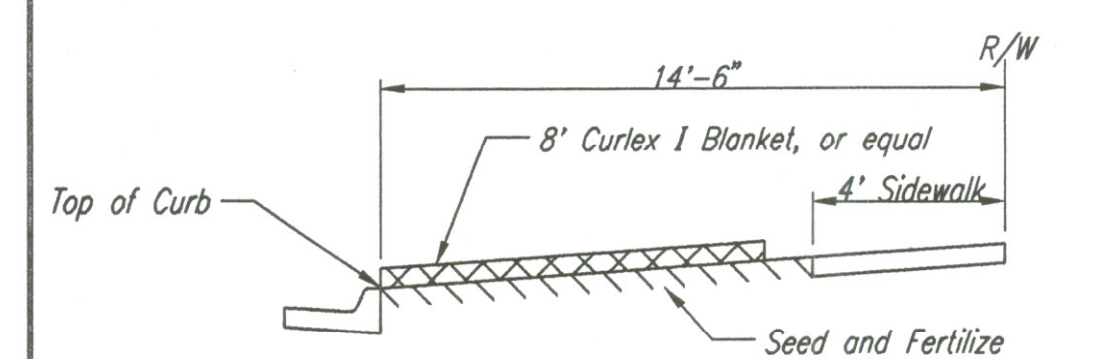
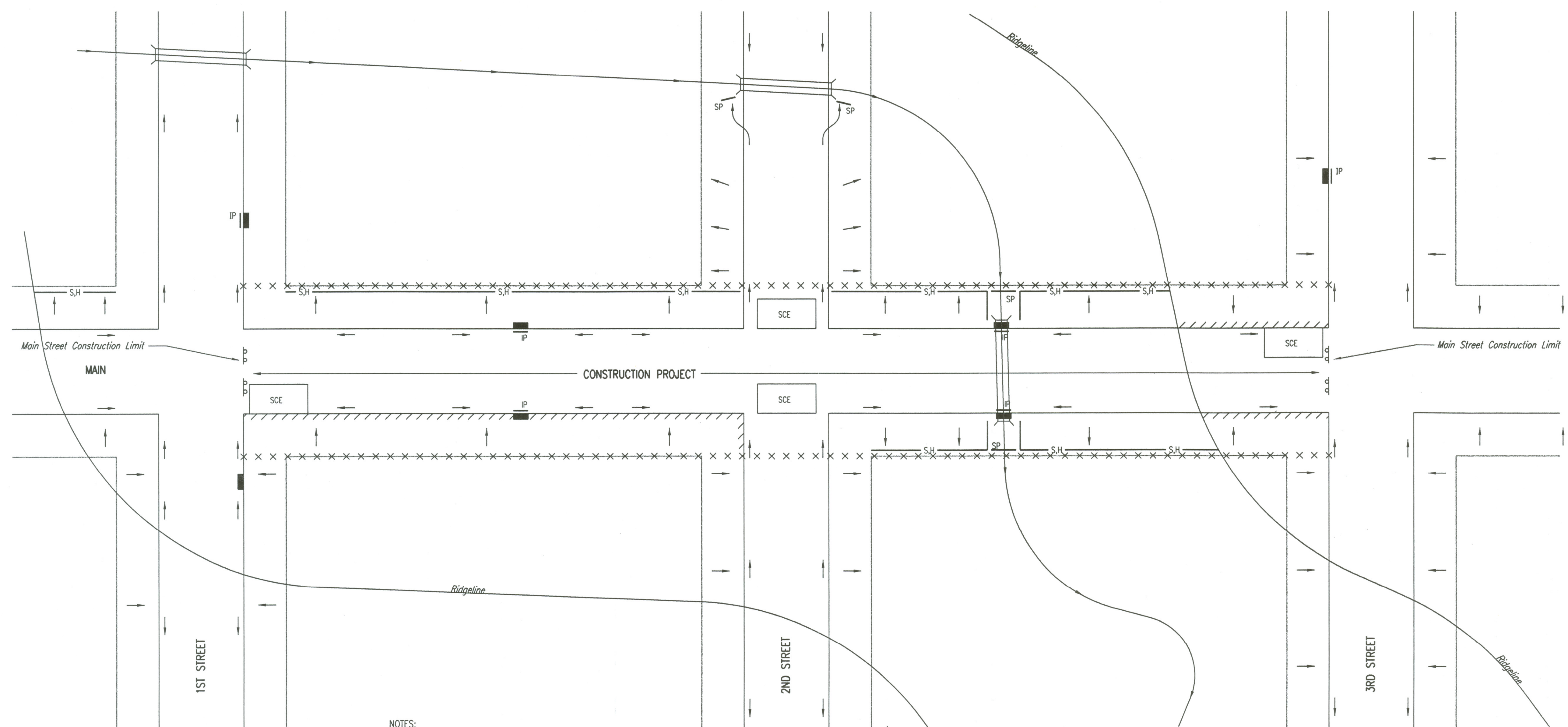

SECTION B-B

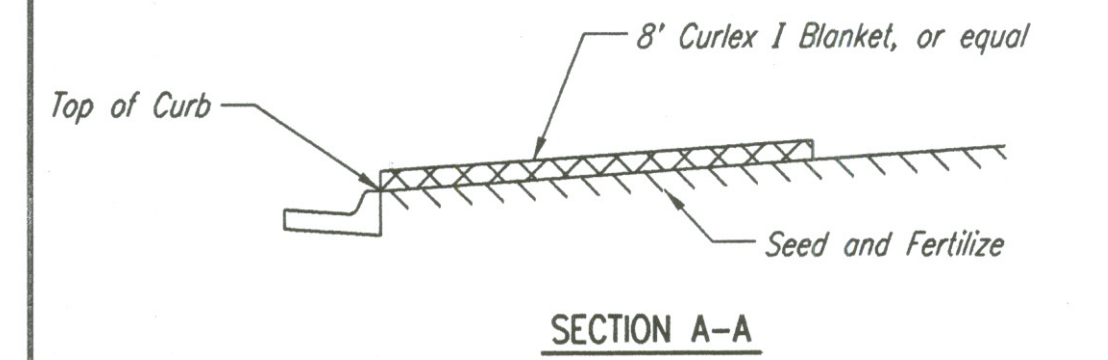

SECTION A-A

BMP-Install 8' wide Curlex I Excelsior Blanket, or equal, on prepared surface back of curb. Edge of blanket will be at back of curb. Install per manufacturer's recommendation, including staples.

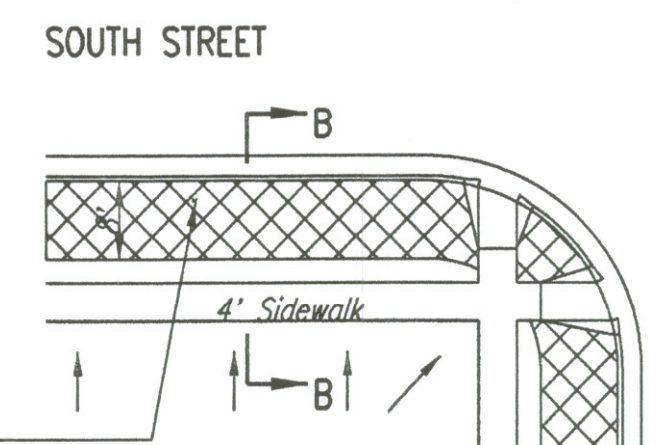
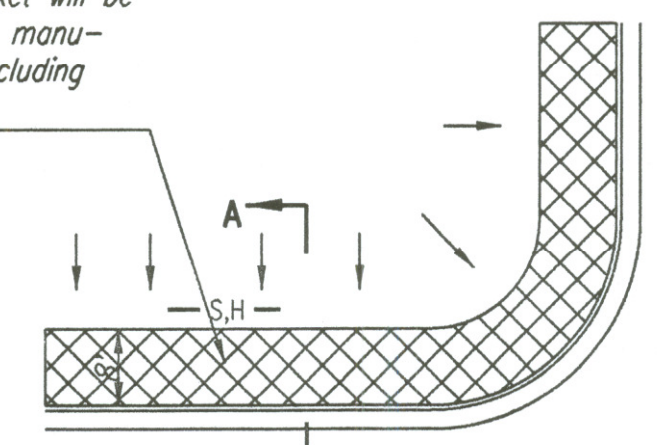

BMP-Install 8' wide Curlex I Excelsior Blanket, or equal, on prepared surface back of curb. Edge of blanket will be at back of curb. Install per manufacturer's recommendation, including staples.

BACK OF CURB PROTECTION DETAIL

NOTES:

- EXCELSIOR MAT TO BE INSTALLED WHEN SOD IS NOT SPECIFIED ON PROJECT.
- EXCELSIOR BLANKET TO BE INSTALLED OVER SEED AND FERTILIZER, AS SPECIFIED IN THE PROJECT SPECIFICATIONS.
- AFTER INSTALLATION OF EXCELSIOR BLANKET, AT LOCATIONS WHERE CONCENTRATED FLOW CARRIES SEDIMENT OVER THE CURB AND INTO THE GUTTER, SUPPLEMENTAL BMP'S WILL BE INSTALLED BY THE CONTRACTOR AS NEEDED, TO FIX THE PROBLEM.

NOTES:

- GENERAL BMP GOAL IS TO KEEP ALL SEDIMENT CONFINED TO THE CONSTRUCTION SITE, AND OUT OF ALL UNDERGROUND PIPES, DITCHES, AND OTHER DRAINAGE FACILITIES.
- THE POINT OF COMPLIANCE IS GENERALLY THE RIGHT-OF-WAY LINES WITHIN THE LIMITS OF CONSTRUCTION.
- BMP'S WILL BE REQUIRED AT ALL POINTS ALONG THE PROJECT WHERE DISTURBED EARTH CAN DRAIN ONTO PRIVATE PROPERTY.
- INLET PROTECTION DEVICES WILL BE REQUIRED WHEREVER WATER CAN DRAIN OFF THE PROJECT SITE INTO AN INLET, INCLUDING ANY SIDE STREET INLETS.
- BMP'S SHALL BE INSTALLED AT CREEK CROSSINGS SO AS TO PREVENT SEDIMENT FROM ENTERING THEREIN.
- STABILIZED CONSTRUCTION ENTRANCES SHALL BE PROVIDED, AS NEEDED, TO PREVENT MUD FROM TRACKING ONTO STREETS NOT UNDER CONSTRUCTION AND ON STREETS WITHIN THE PROJECT LIMITS IF TRAFFIC IS BEING MAINTAINED THROUGH THE PROJECT. THIS WORK SHALL BE SUBSIDIARY.
- ANY MUD TRACKED ONTO STREETS MUST BE REMOVED AT THE END OF EACH WORK DAY.
- THE CONTRACTOR WILL BE REQUIRED TO PLACE BMP'S BACK OF CURB, WHENEVER WATER CAN DRAIN OVER CURB, TO KEEP ERODED SOIL OUT OF THE GUTTERLINES, IN ACCORDANCE WITH THE FOLLOWING:
  - THE BMP REQUIRED WILL BE CURLEX I EXCELSIOR BLANKET, OR EQUAL. SAID BLANKET SHALL BE PLACED OVER THE APPROPRIATE SEED AND FERTILIZER, AS SPECIFIED IN THE PROJECT SPECIFICATIONS. (SEE BACK OF CURB PROTECTION DETAIL)
  - THIS BMP SHALL BE INSTALLED IMMEDIATELY WHENEVER THE CURB IS BACKFILLED TO WITHIN 3" OF THE TOP OF CURB. (SEE CURB BACKFILL DETAIL) OTHER BMP'S MAY BE REQUIRED AT LOCATIONS WHERE CONCENTRATED FLOW CARRIES SEDIMENT OVER THE CURB.
  - ADDITIONALLY, OTHER BMP'S (HAYBALES, SILT FENCE, ETC.) WILL BE INSTALLED AT LOCATIONS OF CONCENTRATED FLOW RESULTING IN SEDIMENT OVERRUNNING THE MAT.
  - SHOULD THE PROJECT PLANS SPECIFY THAT THE RIGHT-OF-WAY IS TO BE SODDED, THE EXCELSIOR MAT WILL NOT BE REQUIRED SO LONG AS THE SOD IS PLACED WITHIN 48 HOURS AFTER CURB BACKFILL REACHES A HEIGHT OF 3" OR LESS FROM TOP OF CURB. (SEE DETAIL)
- THE BMP SPECIFIED IN ITEM A WILL NOT BE REQUIRED DURING TEMPORARY SEEDING, HOWEVER OTHER BMP'S SHALL BE INSTALLED AND MAINTAINED TO CONTROL EROSION.
- NO SEPARATE MEASUREMENT OR PAYMENT WILL BE MADE FOR INSTALLATION OF THE EXCELSIOR MAT. THIS ITEM INCLUDING ALL MATERIALS, TOOLS, EQUIPMENT AND INCIDENTALS NECESSARY TO COMPLETE THE WORK SHALL BE SUBSIDIARY TO OTHER EROSION CONTROL AND SEEDING BID ITEMS.

LEGEND

- R-O-W LIMITS
- DRAINAGE FLOW PATH
- × × × × × R/W LIMIT WITHIN CONSTRUCTION LIMIT
- STORM WATER INLETS
- IP INLET PROTECTION
- S.H.— SILT FENCE OR HAYBALE BMP
- SP— STREAM PROTECTION
- SCE STABILIZED CONSTRUCTION ENTRANCE
- ////// BACK OF CURB PROTECTION

DSNR: 1/1997/9/2602/STANDARDS/EROSION/SEBMP.DGN 12-17-2001 9:34:49 LAST REV: BY:

		<b>SOIL EROSION BMP'S STREET IMPROVEMENT PROJECTS</b>	
		CHRISTOPHER M. CARRIER, P.E. STORM WATER ENGINEER	
PROJECT NUMBER	OCA NO.		
DATE	April, 2002		SHEET 626 OF 1122