

M1-4
0.36 sq m

* OPTICALLY SPACE NUMERALS ABOUT VERTICAL CENTERLINE.

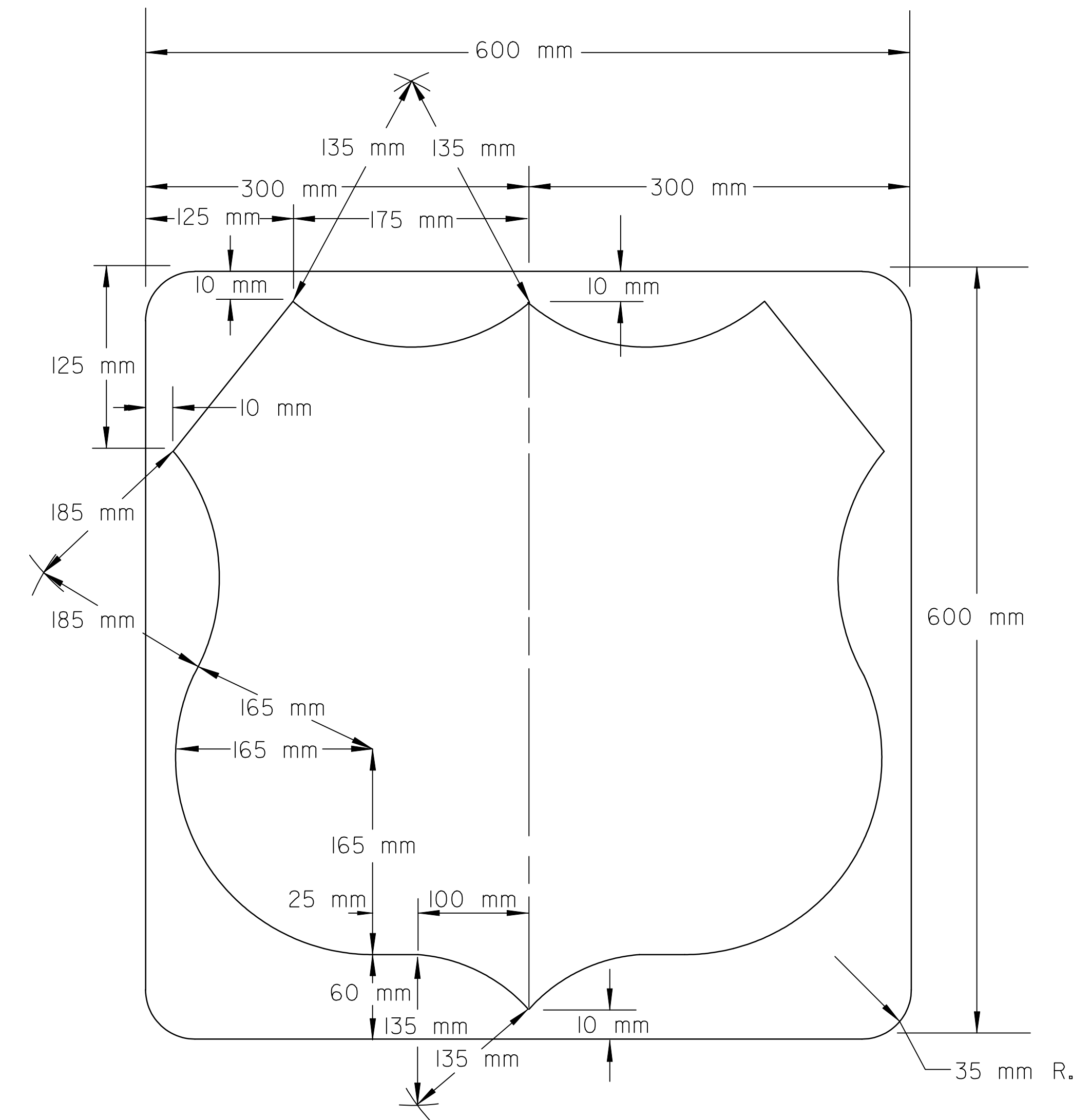

NOTE:

COLOR SPECIFICATIONS (DIRECT SCREEN PROCESS)
SIGN FACE SHALL BE COVERED WITH HIGH PERFORMANCE WHITE RETROREFLECTIVE SHEETING.
DIGITS AND AREA AROUND SHIELD SHALL BE BLACK PROCESS INK.
SEE FLAT SIGN DETAIL SHEET FOR ALUMINUM ALLOYS AND THE THICKNESS REQUIRED.
THE TYPE OF ADHESIVE FOR RETROREFLECTIVE SHEETING SHALL BE HEAT ACTIVATED OR PRESSURE SENSITIVE.

ALL DIMENSIONS ARE IN MILLIMETERS.

3					
2					
1	10-28-99	CHANGED DIMENSIONS	TCP	MPM	
NO.	DATE	REVISION	BY	APP'D	

KANSAS DEPARTMENT OF TRANSPORTATION
DESIGN DETAILS FOR
2 DIGIT US-ROUTE MARKER
(INDEPENDENT USE)
TE518SI 9-1-94

FHWA APPROVAL	11-9-99	APP'D	NELDA A. BUCKLEY
DESIGNED KH	DETAILED KH	QUANTITIES	TRACED KH
DESIGN CK.	DETAIL CK.	QUAN. CK.	TRACE CK.

RECORD DRAWING