

- NOTES FOR DETAIL 'A':
- The anchor bolts for the signal pole shall be tack welded together in a 16" or 20" diameter bolt pattern (on center as is shown) to maintain the required bolt circle pattern and to aid in vertical positioning while the reinforced concrete base is being poured.
  - Use anti-seize compound on all threads.
  - The 12' 0" x 5/8" ground rod is to be positioned in place PRIOR TO pouring the reinforced concrete base.
  - Class 'A' concrete shall be used to construct the reinforced concrete base.
  - Construct a 6" thick x 36" square concrete cap after pole has been erected and plumbed. Chamfer the top edge @ 1". Subject to approval by the engineer PRIOR TO construction of cap.
  - All conduits shall have an approved plastic or metal bushing installed above the base @ 3" ± to prevent cable chafing.
  - Use #6 Bare Copper Ground Conductor from clamp on ground rod to ground bolt in signal pole access hole.
  - A single conductor stranded #8 Green Wire shall carry the equipment ground from the ground lug of all signal poles to the controller cabinet and the power disconnect box. When necessary, the equipment ground can be spliced in the service box with a split bolt connector. (Subject to approval by the engineer)

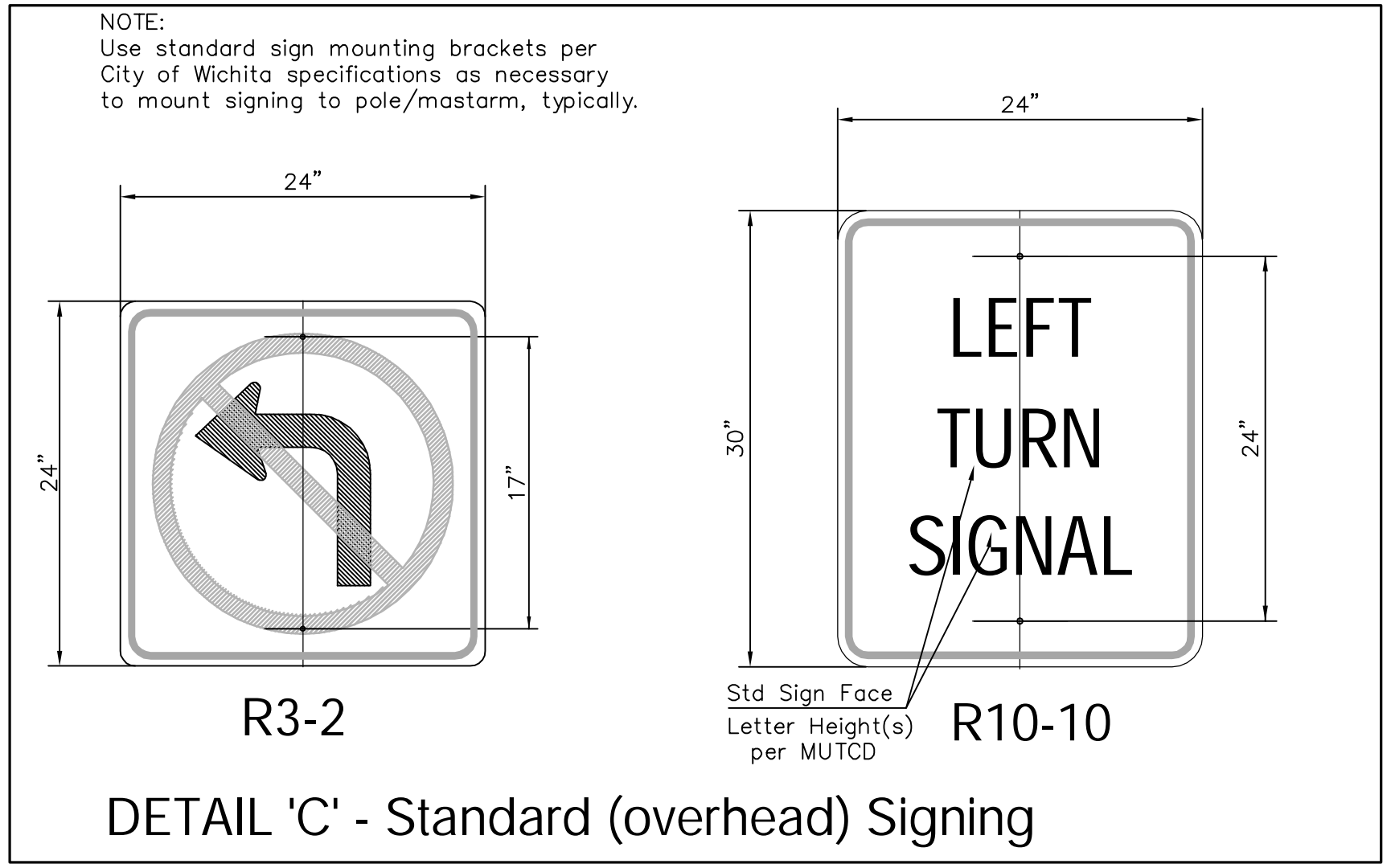

- Pole base shown is for information only. Optional bases that may be purchased may vary in actual appearance in accordance with manufacturing company's specifications
- (\*\*) The back rake for pole is as follows:  
 1" back rake (1/4 bubble) for mastarms 40' and under  
 1 1/2" back rake (1/3 bubble) for mastarms over 40'
- (\*\*\*) The rake for pole base is as follows:  
 2% back rake (1/4 bubble) for mastarms 40' and under  
 2.6% back rake (1/3 bubble) for mastarms over 40'