

DRUMS AND TRIM LINE CHANNELIZERS SHALL BE RETROREFLECTORIZED FULL CIRCUMFERENCE WITH AT LEAST TWO ORANGE AND TWO WHITE 150 mm TO 200 mm WIDE STRIPES. ADDITIONAL STRIPES MAY BE NON-REFLECTIVE. IF THERE ARE NON-REFLECTIVE SPACES BETWEEN ADJACENT STRIPES, THEY SHALL BE NO MORE THAN 50 mm WIDE.

ALL RETROREFLECTIVE STRIPES ON DRUMS SHALL BE TYPE III HIGH PERFORMANCE SHEETING. THE WHITE STRIPES ON TRIM LINE CHANNELIZERS SHALL BE TYPE III HIGH PERFORMANCE SHEETING. PROJECTS LET AFTER JANUARY 1, 2002, WILL REQUIRE THAT THE ORANGE STRIPES ON ALL TRIM LINE CHANNELIZERS BE FLUORESCENT ORANGE PRISMATIC GRADE SHEETING.

FOR RAILS LESS THAN 36" LONG, 4" WIDE STRIPES MAY BE USED.

THE ENTIRE AREA OF BARRICADE RAILS, BOTH FRONT AND BACK, SHALL BE FULLY REFLECTORIZED WITH TYPE III HIGH PERFORMANCE RETROREFLECTIVE SHEETING.

THE STRIPES SHALL SLOPE DOWNWARD TO THE TRAFFIC SIDE FOR CHANNELIZATION.

THE ARROW PANEL SHALL BE BLACK ON FLUORESCENT ORANGE PRISMATIC GRADE SHEETING. THE STRIPES SHALL BE ORANGE AND WHITE TYPE III HIGH PERFORMANCE RETROREFLECTIVE SHEETING SLOPING DOWNWARD IN THE DIRECTION TRAFFIC IS TO PASS.

THE DIRECTION INDICATOR BARRICADE SHOULD BE USED IN SERIES TO DIRECT THE MOTORIST INTO THE INTENDED LANE OF TRAVEL.

THE ARROW PANEL SHOULD NOT BE VISIBLE TO OPPOSING TRAFFIC.

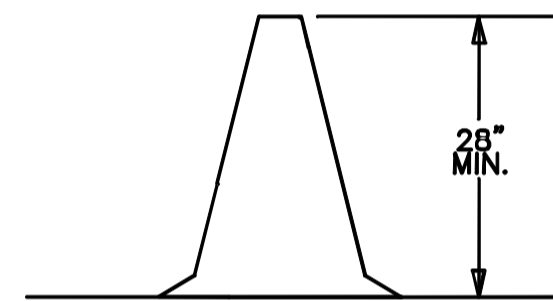

ORANGE CONES

CONES MAY BE USED AS CHANNELIZING DEVICES FOR DAYTIME OPERATIONS ONLY. THEY WILL NOT BE PAID FOR SEPARATELY, BUT WILL BE SUBSIDIARY TO OTHER TRAFFIC CONTROL BID ITEMS. THE ENGINEER MAY REQUIRE THAT CONES BE SUPPLEMENTED BY OTHER TRAFFIC CONTROL DEVICES IN CERTAIN SITUATIONS.

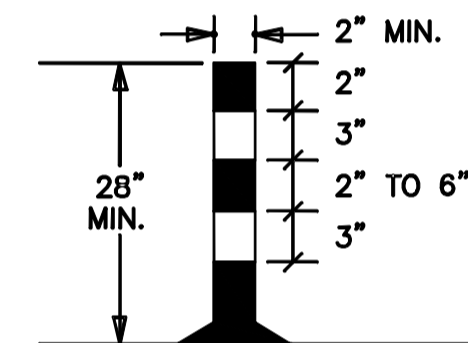

TUBULAR MARKERS

TAPER FORMULAS:

$$L = WS \text{ FOR SPEEDS OF 45 MPH OR MORE}$$

$$L = WS^2 / 60 \text{ FOR SPEEDS OF 40 MPH OR LESS}$$

WHERE: L = MINIMUM LENGTH OF TAPER IN FEET  
S = NUMERICAL VALUE OF POSTED SPEED  
W = WIDTH OF OFFSET IN FEET

CHANNELIZER PLACEMENT:

(A) THE SPACING BETWEEN DEVICES IN THE TAPER SHOULD NOT EXCEED A DISTANCE IN FEET EQUAL TO THE POSTED SPEED LIMIT IN MPH PRIOR TO WORK STARTING.

(B) THE SPACING BETWEEN DEVICES IN THE WORK ZONE SHOULD NOT EXCEED A DISTANCE IN FEET EQUAL TO TWO TIMES THE POSTED SPEED LIMIT IN MPH PRIOR TO WORK STARTING.

(C) CHANNELIZING DEVICES SHALL BE PLACED FOR OPTIMUM VISIBILITY, NORMALLY AT RIGHT ANGLES TO THE TRAFFIC FLOW.

(D) CHANNELIZING DEVICES PLACED ALONG SHOULDER EDGES OR IN DROPOFFS SHALL HAVE A MINIMUM OF 24' FROM THE TOP OF THE CHANNELIZING DEVICE TO THE TOP OF THE PAVEMENT.

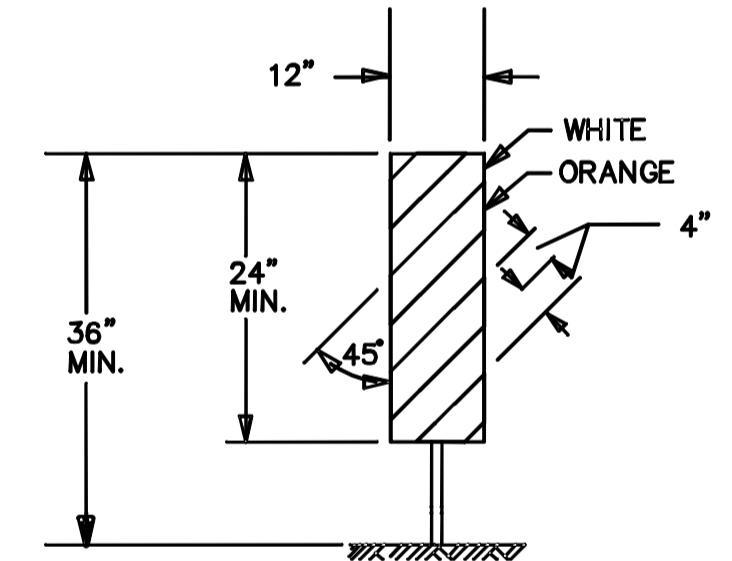

VERTICAL PANEL

THE ENTIRE AREA OF VERTICAL PANELS, BOTH FRONT AND BACK, SHALL BE FULLY REFLECTORIZED WITH TYPE III HIGH PERFORMANCE RETROREFLECTIVE SHEETING. THE STRIPES SHALL SLOPE DOWNWARD TO THE TRAFFIC SIDE FOR CHANNELIZATION.

ITEM	LOCATION	CROSS-OVERS	DIVERSIONS	TANGENTS	TAPERS	RAMPS	HEAD TO HEAD	OBJECT IDENTIFIER
		PORTABLE	DRUMS	YES	YES	YES	YES	YES
	TRIM LINES	YES	YES	YES	YES	YES	(1)	YES
	VERTICAL PANELS	(2)	(2)	(2)	(2)	(2)	(1,2)	YES
	DIRECTION INDICATOR BARRICADE	NO	NO	NO	YES	NO	NO	NO
	TYPE II BARRICADE	(2)	(2)	(2)	(2)	NO	NO	YES
FIXED	TUBULAR MARKERS	(3)	(3)	(3)	NO	(3)	YES	NO
	VERTICAL PANELS	(3)	(3)	(3)	(3)	(3)	(3)	YES

- (1) Not allowed on centerline delineation along freeways or expressways.
- (2) The stripes shall slope downward to the traffic side for channelization.
- (3) May be used upon the approval of the Engineer.

3	11-19-03	CHANGED BORDER	B.H.	S.A.B.
2	9-26-02	MODIFIED NOTES	M.H.	S.A.B.
1	11-13-01	REVISED CHANNELIZING DEVICE MATRIX	J.H.	S.A.B.
NO.	DATE	REVISION	BY	APP'D

KANSAS DEPARTMENT OF TRANSPORTATION

CHANNELIZING DEVICES

TE702SI 9/1/00

DESIGNED	L.E.R.	DESIGNED	B.A.H.	APP'D	Michael P. McKenna
DESIGN CK.	DETAIL CK.	QUANTITIES	TRACED		