

STATE	PROJECT NO.	YEAR	SHEET NO.	TOTAL SHEETS
KANSAS	472-84639	2008	89	142

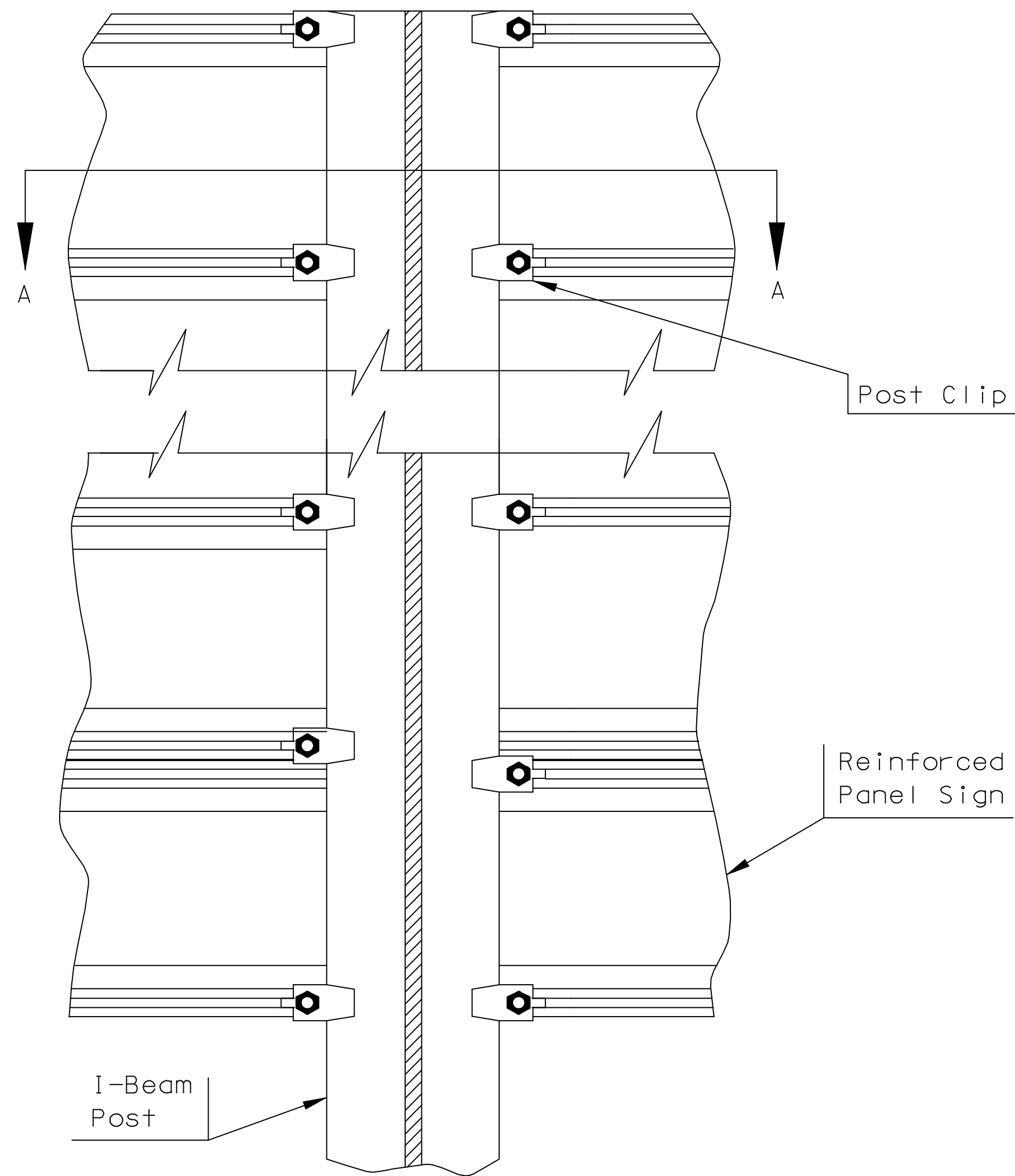

Mounting of Reinforced Panels to I-Beam Post

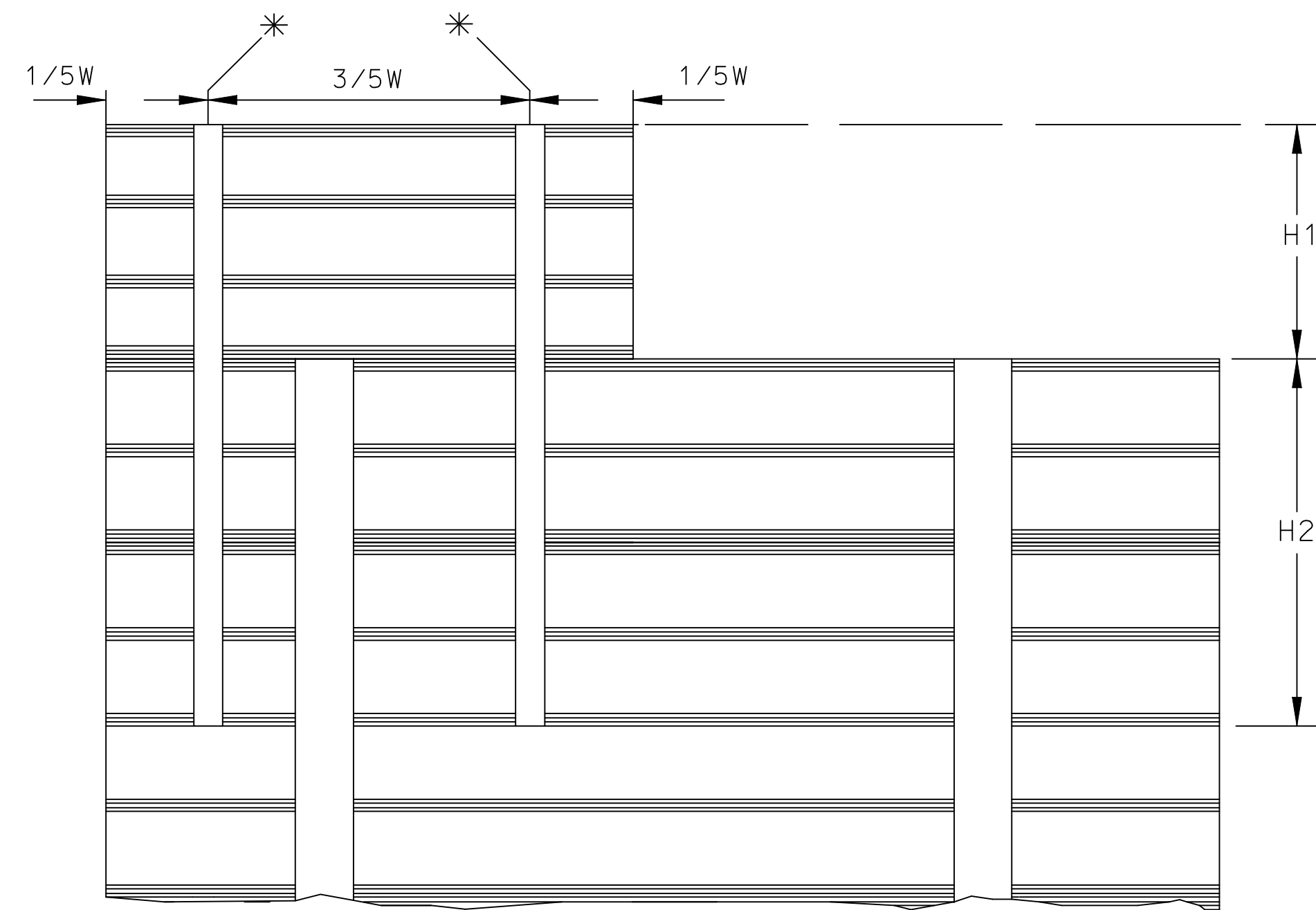
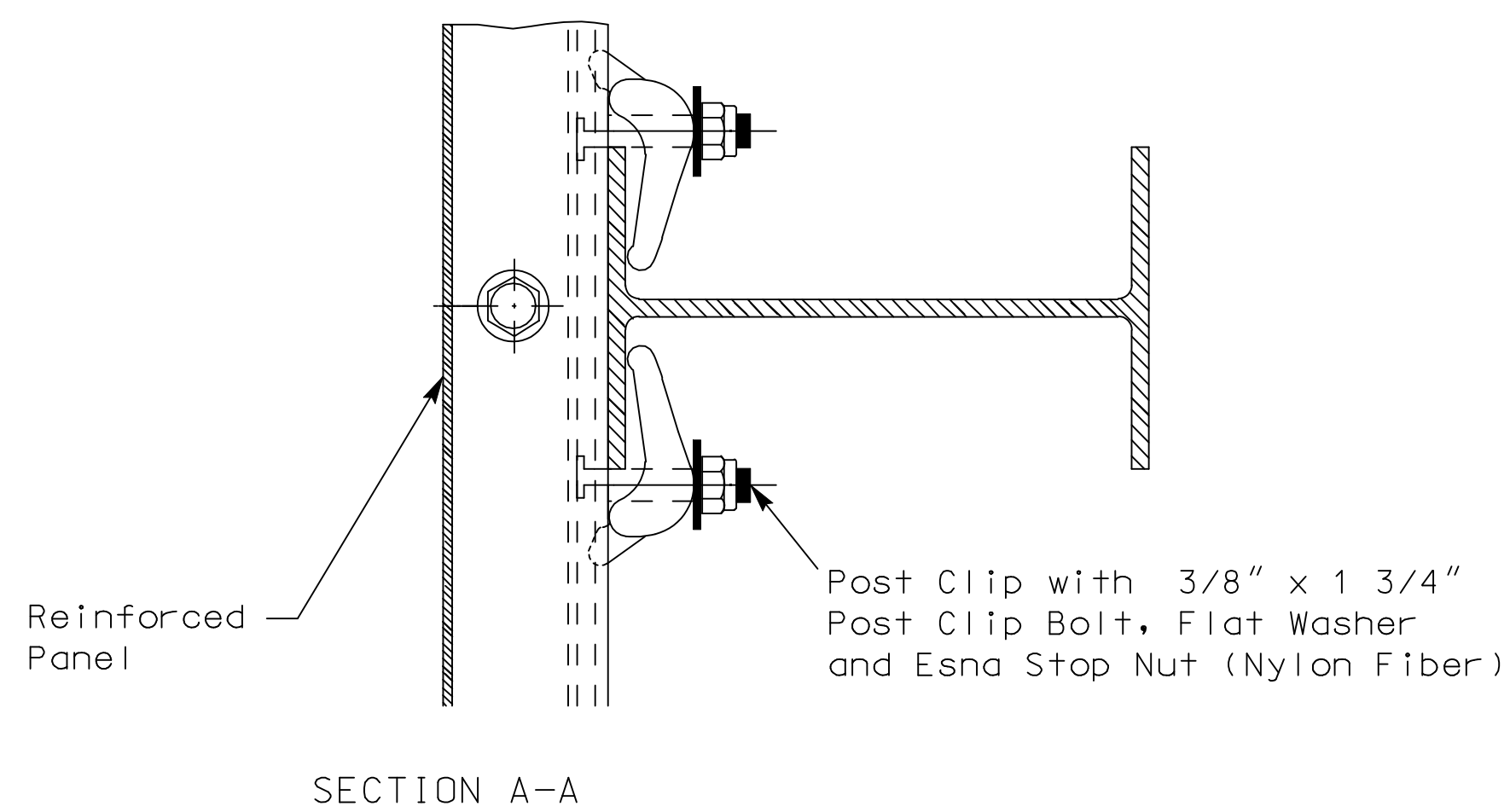

E1-5 Mounting from Right Exit
(2 I-Beams)

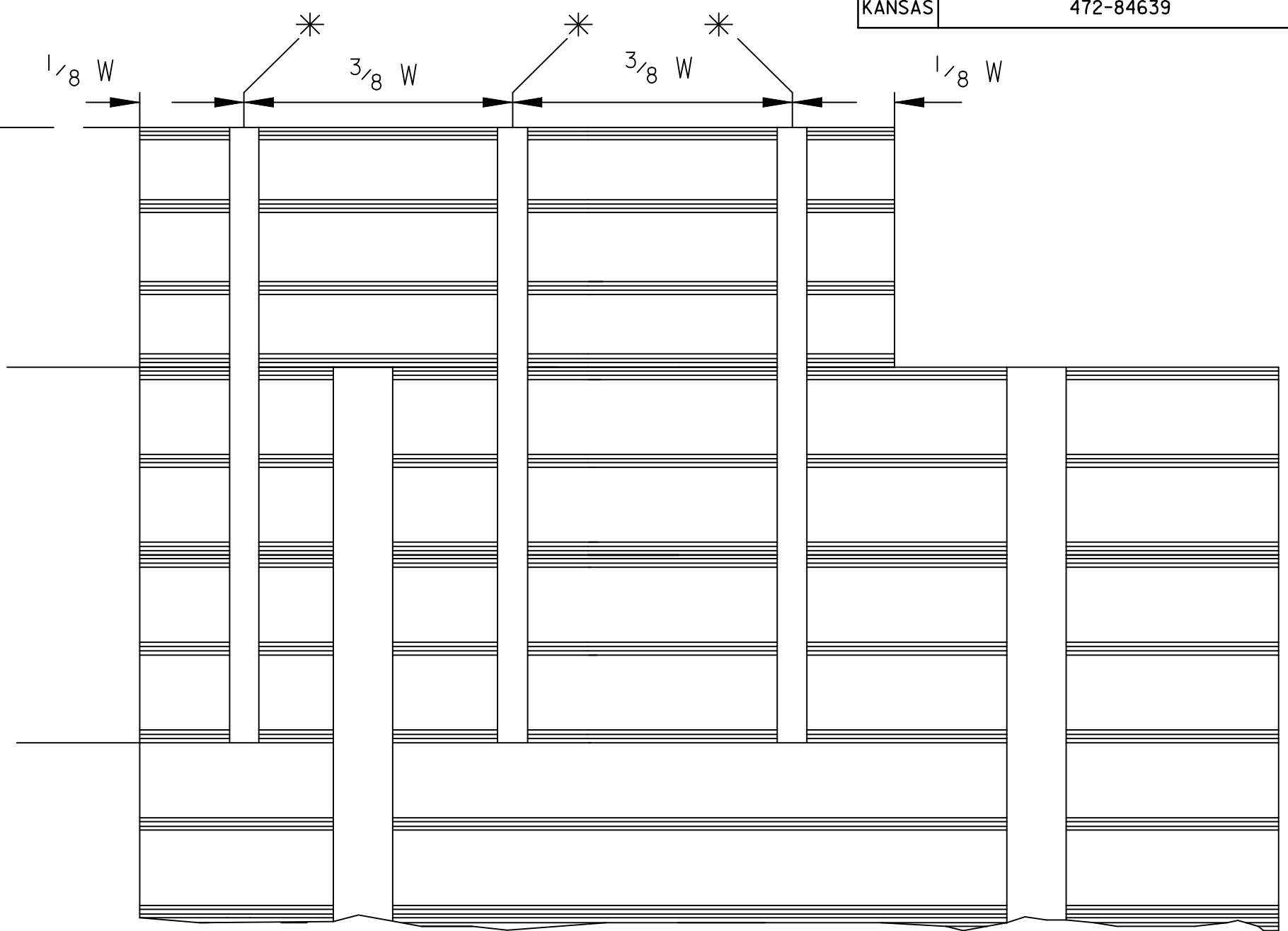

E1-5 Mounting from Right Exit
(3 I-Beams)

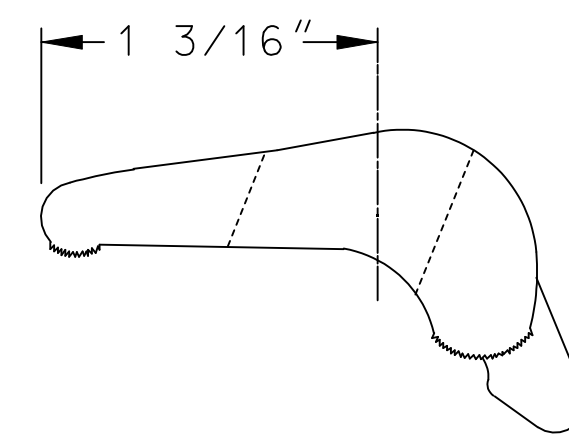
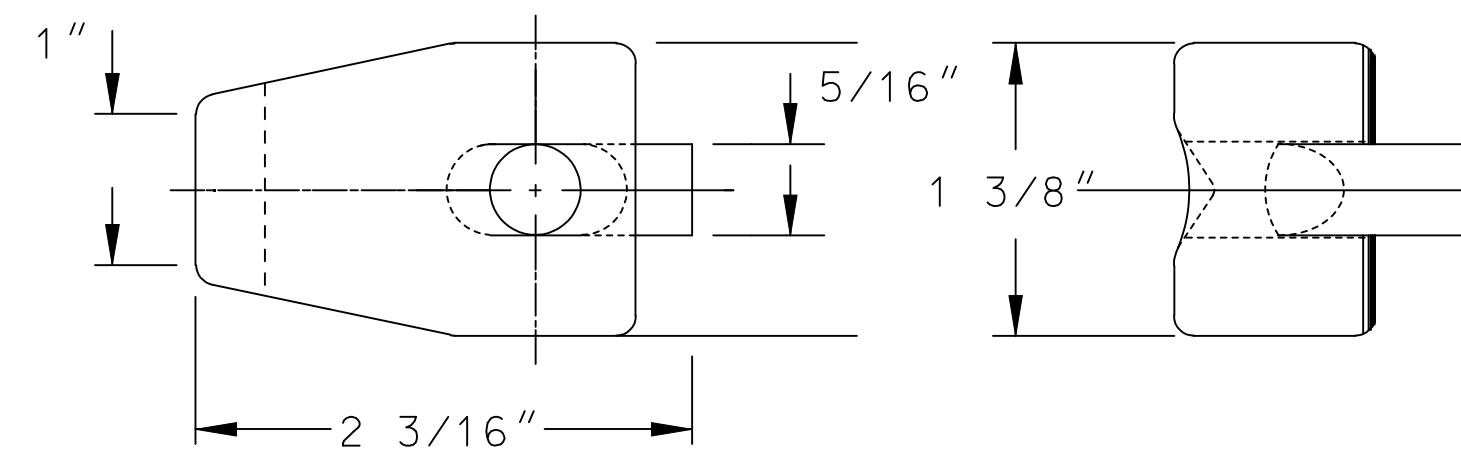

POST CLIP
ALUMINUM

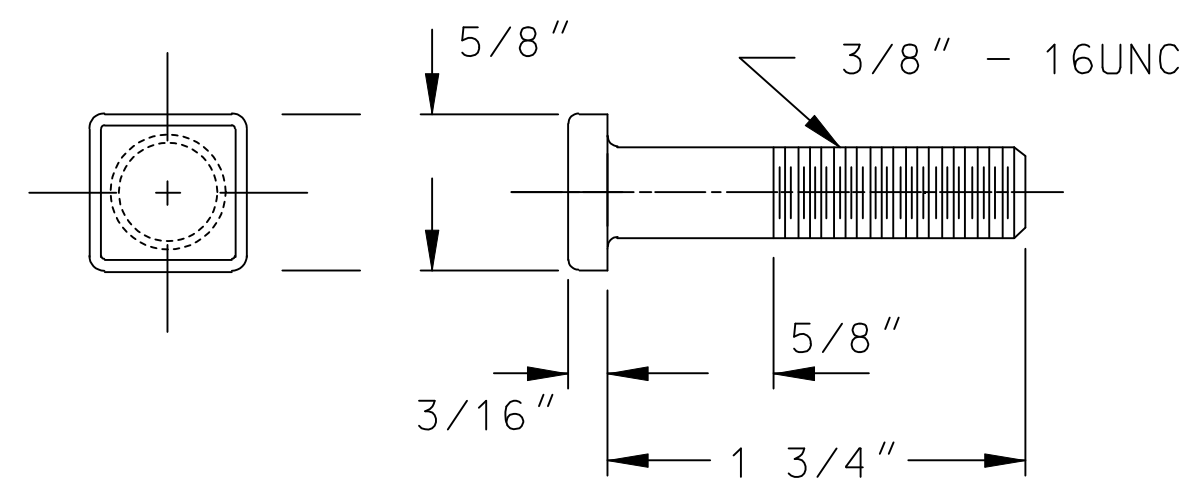

POST CLIP BOLT
ALUMINUM

NOTES:

- * - Centerline of Aluminum I-Beam
- H1 - Height of added sign (E1-5)
- H2 - H1 + 12" or to the bottom of the next stiffener
- The E1-5 sign shall be positioned above the guide sign according to the direction of the exit:
- Right exit - right edge of sign
- Left exit - left edge of sign
- Two exits (one left and one right) - center of sign
- The aluminum I-Beams are to be mounted at the spacings shown. If the I-Beam spacing conflicts with the sign posts, then the I-Beam is to be moved to the side of the sign post that more closely fits the spacings and as determined by the Engineer.
- The post clip bolt may have a rectangular head, if the smaller dimension is equal to the square head dimension.

All dimensions are in inches.

3				
2				
1				
NO.	DATE	REVISIONS	BY	APP'D

KANSAS DEPARTMENT OF TRANSPORTATION
DETAILS FOR MOUNTING
REINFORCED PANEL SIGN
ON I-BEAM POST

TE490	07-01-03	APP'D Steven A. Buckley
DESIGNED DDG	DETAILED BXM	QUANTITIES TRACED
DESIGN CK. SAB	DETAIL CK. DDG	QUAN. CK. TRACE CK.

Plotted By : drp
 Plot File : I:\2006\06655\Standards\06655-TE490.dgn
 Plot Date : 1/16/2008