

REBAR SCHEDULE

Bar	Shape	No.	Length	Weight
a1	U	1	9'5"	6.29
a2	U	1	7'7"	5.07
a3	U	1	7'2"	4.79
a4	U	1	6'9"	4.51
a5	U	1	6'4"	4.23
a6	U	1	6'1"	4.06
b1	—	2	2'9"	3.67
b2	—	2	5'10"	7.79
c	—	6	6'11"	27.72
d	—	1	5'0"	3.37
e	—	1	3'10"	2.56
Total Rebar			74.03 Lbs.	
Concrete			1.40 C.Y.	

A Deduction in Concrete Quantities Has Been Made for Pipe Openings Through the Headwall
 * Field Bend or Cut Reinforcing as Required for Clearance.
 All Concrete Reinforcement to be #4 Rebar
 All Rebar to Have Min. of 1 1/2" Conc. Cover

HEADWALL FOR 24" RCP

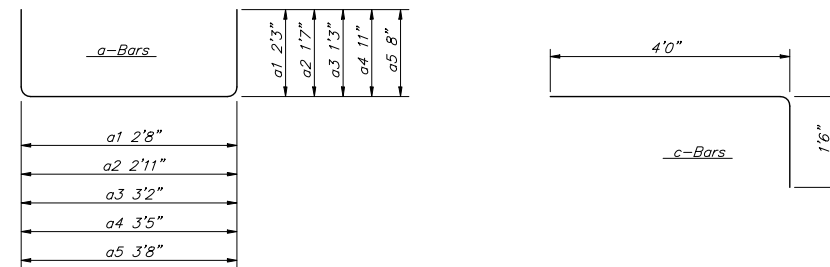
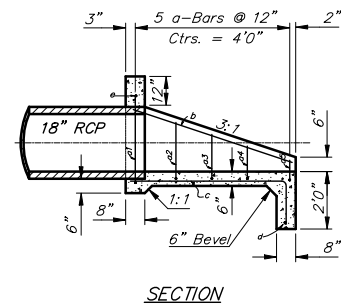
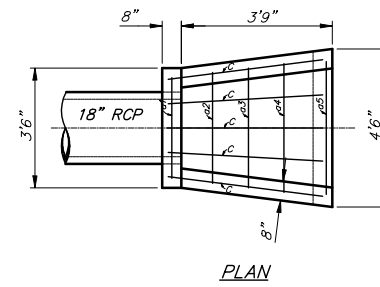

REBAR SCHEDULE

Bar	Shape	No.	Length	Weight
a1	U	1	7'2"	4.79
a2	U	1	6'1"	4.06
a3	U	1	5'8"	3.79
a4	U	1	5'3"	3.51
a5	U	1	5'0"	3.34
b	—	2	4'0"	5.34
c	—	5	5'6"	18.37
d	—	1	4'0"	2.67
e	—	1	3'2"	2.12
Total Rebar			47.99 Lbs.	
Concrete			0.91 C.Y.	

A Deduction in Concrete Quantities Has Been Made for Pipe Openings Through the Headwall
 * Field Bend or Cut Reinforcing as Required for Clearance.
 All Concrete Reinforcement to be #4 Rebar
 All Rebar to Have Min. of 1 1/2" Conc. Cover

HEADWALL FOR 18" RCP

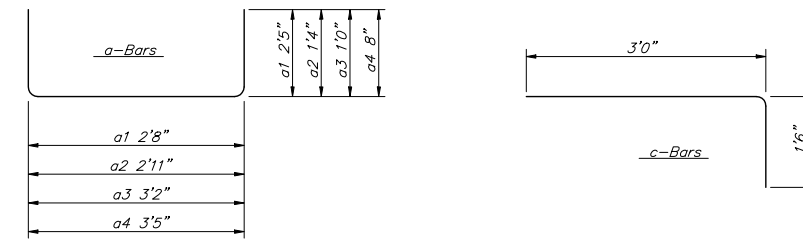
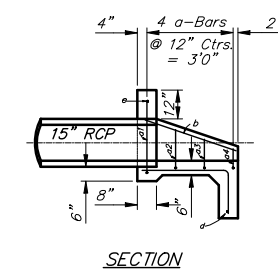
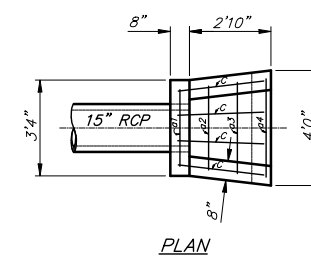

REBAR SCHEDULE

Bar	Shape	No.	Length	Weight
a1	U	1	7'6"	5.01
a2	U	1	5'7"	3.73
a3	U	1	5'2"	3.45
a4	U	1	4'9"	3.17
b	—	2	4'0"	5.34
c	—	4	5'6"	14.70
d	—	1	3'5"	2.28
e	—	1	2'8"	1.78
Total Rebar			39.46 Lbs.	
Concrete			0.67 C.Y.	

A Deduction in Concrete Quantities Has Been Made for Pipe Openings Through the Headwall
 * Field Bend or Cut Reinforcing as Required for Clearance.
 All Concrete Reinforcement to be #4 Rebar
 All Rebar to Have Min. of 1 1/2" Conc. Cover

HEADWALL FOR 15" RCP

- GENERAL NOTES**
- ALL PIPES SHALL BE FLUSH CUT PRIOR TO BEING CAST INTO CONCRETE HEADWALL
 - CONCRETE USED IN HEADWALL CONSTRUCTION SHALL BE SAME AS PER CITY STANDARD PAVING MIX EXCEPT THAT IT SHALL HAVE A MINIMUM 28 DAY COMPRESSIVE STRENGTH OF 4000 PSI.
 - ALL EXPOSED EDGES SHALL BE BEVELED 1/2"
 - REINFORCING STEEL SHALL COMPLY TO A.S.T.M. DESIGNATION A615 GRADE 60. ALL DIMENSIONS RELATIVE TO REINFORCING STEEL ARE TO CENTERLINE OF BAR UNLESS OTHERWISE NOTED.
 - THE "REIN. CONC. HEADWALL" SHALL BE PAID FOR AT THE UNIT PRICE BID PER EACH IN PLACE WHICH SHALL INCLUDE ALL LABOR, MATERIALS, EXCAVATION, CONCRETE, REINFORCING STEEL AND ALL OTHER INCIDENTAL ITEMS NECESSARY TO COMPLETE THE WORK. MATERIAL QUANTITIES SHOWN ARE FOR INFORMATION ONLY.

Baughman		HEADWALL DETAIL	
Baughman Company, P.A. 315 Elm St. Woburn, MA 02111 F 3162627271 F 3162620149			
ENGINEERING SURVEYING PLANNING LANDSCAPE ARCHITECTURE			
PROJECT NUMBER 472-84249	DESIGN BLP/DMV	DRAWN JAK	
REVISIONS:	APPROVED	DATE 01/06	
	SCALE Noted	SHEET	
			24 OF 39