

**EXPANSION JOINT**

NOTE: Extra Thickness to be Subsidiary to Price of Square Yards Pavement

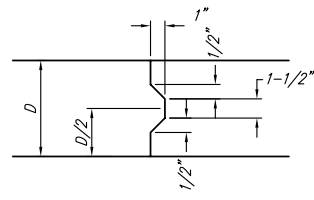

**KEYWAY DETAIL**

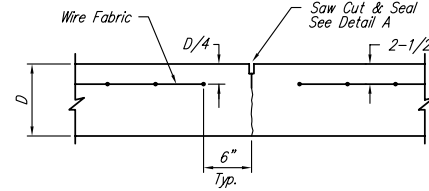

**CONTRACTION JOINT DETAIL (C.J.)**

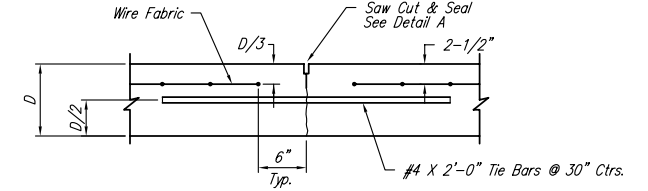

**LONGITUDINAL JOINT DETAIL (L.J.)**

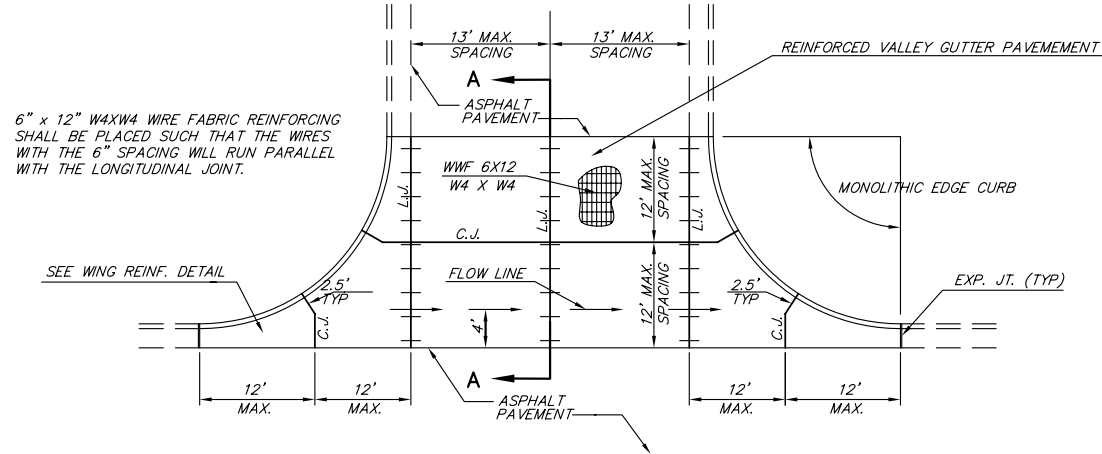

**PLAN**



**OPTIONAL LONGITUDINAL JOINT DETAIL (L.J.)**

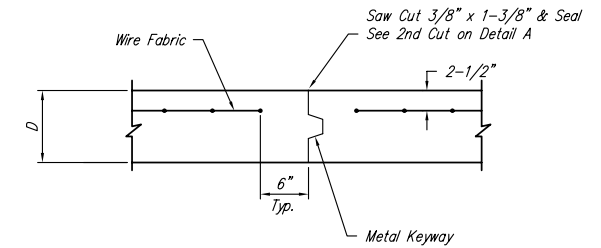

**OPTIONAL CONTRACTION JOINT**

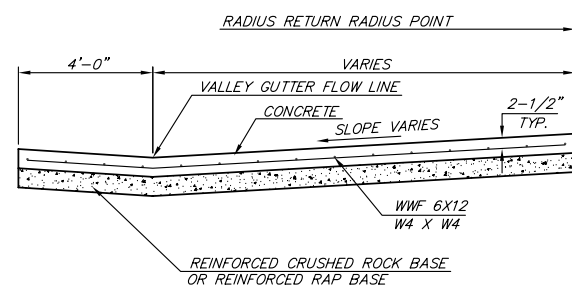

**SECTION A-A**

**REINFORCED VALLEY GUTTER DETAIL**

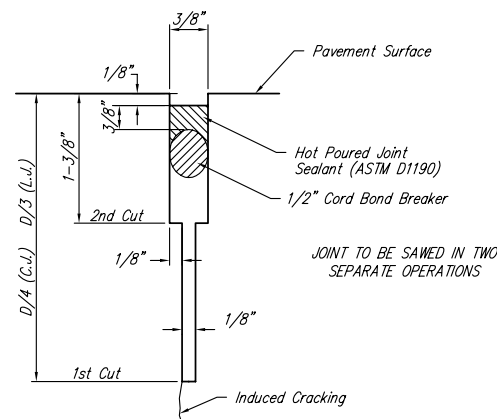

**SAW JOINT DETAIL**

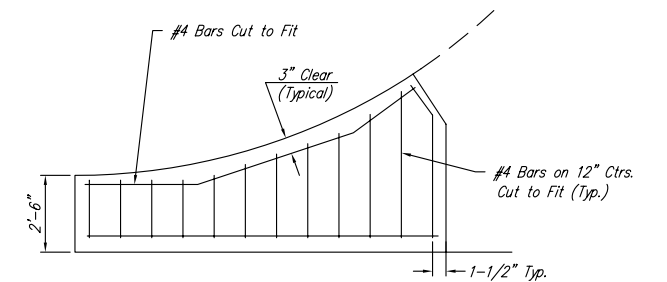

**WING REINFORCING DETAIL**

H:\CIVIL\00062\PAV\PHASE3\00062ED2.DWG   <b>THE CITY OF WICHITA</b> CITY ENGINEER'S OFFICE CITY HALL - SEVENTH FLOOR 455 NORTH MAIN STREET WICHITA, KANSAS 67202 (316) 268-4501 (316) 268-4114 FAX	<b>VALLEY GUTTER DETAILS</b>	
	JIM ARMOUR - ACTING CITY ENGINEER	
	PROJECT NUMBER 472-83269	OCA NUMBER 765884
	DATE JULY 2004	SHEET 3 OF 18