

**EXPANSION JOINT**

NOTE: Extra Thickness to be Subsidiary to Price of Square Yards Pavement

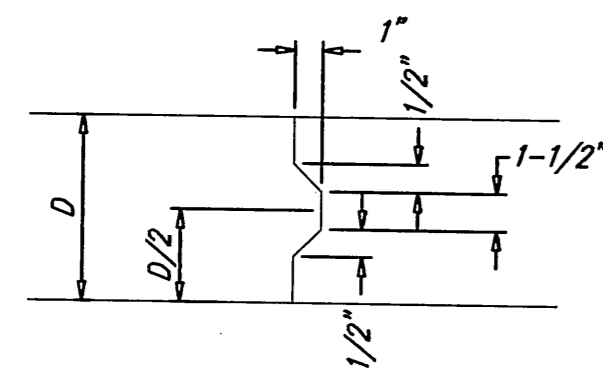

**KEYWAY DETAIL**

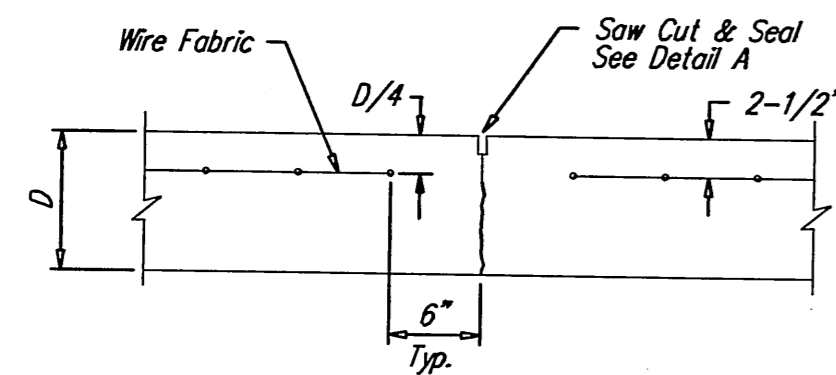

**CONTRACTION JOINT DETAIL (C.J.)**

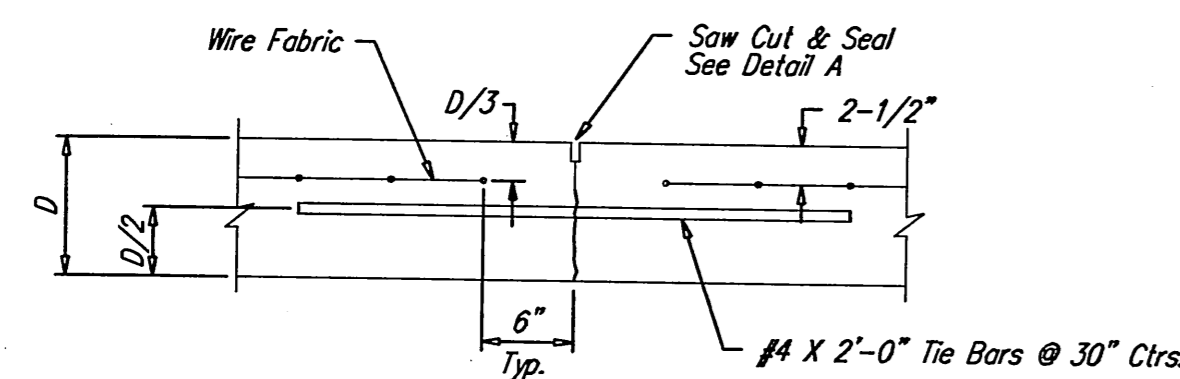

**LONGITUDINAL JOINT DETAIL (L.J.)**

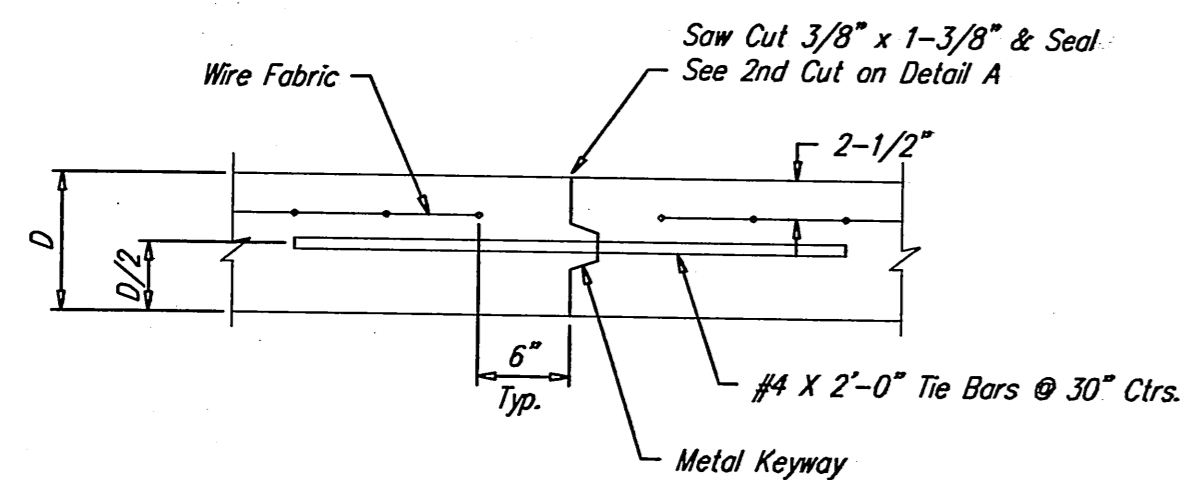

**OPTIONAL LONGITUDINAL JOINT DETAIL (L.J.)**

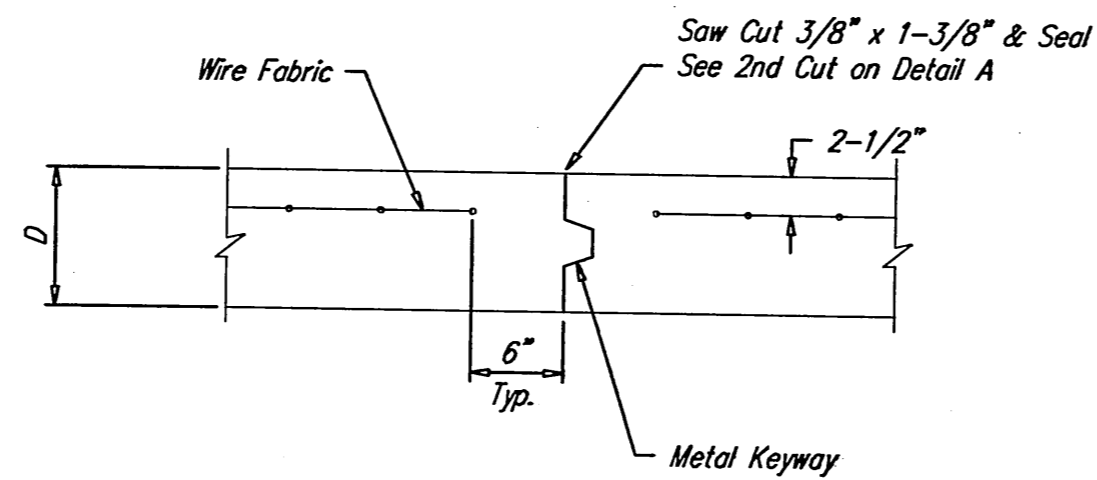

**OPTIONAL CONTRACTION JOINT**

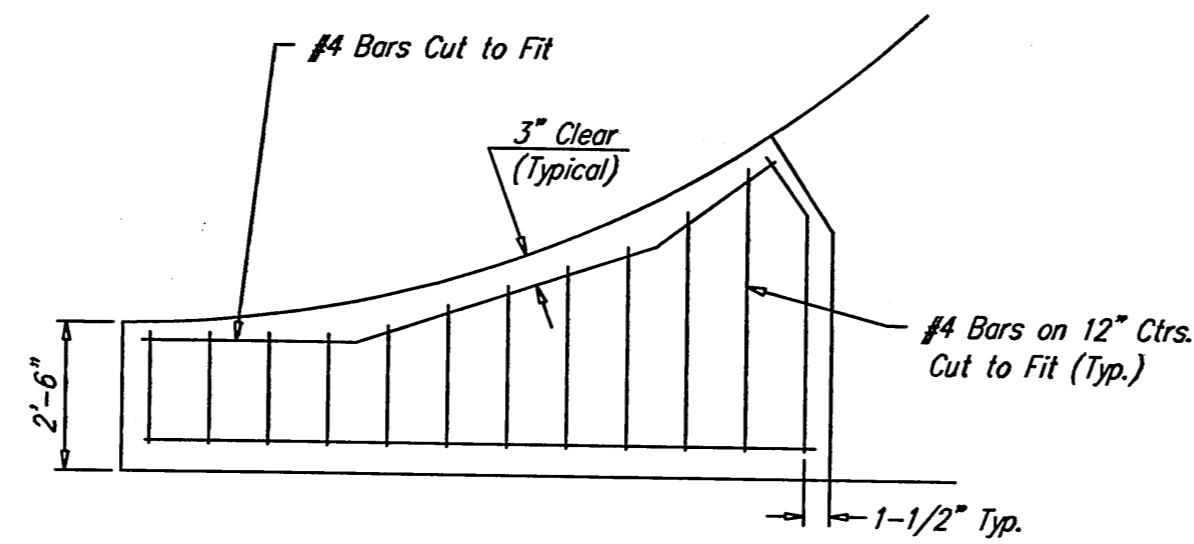

**WING REINFORCING DETAIL**

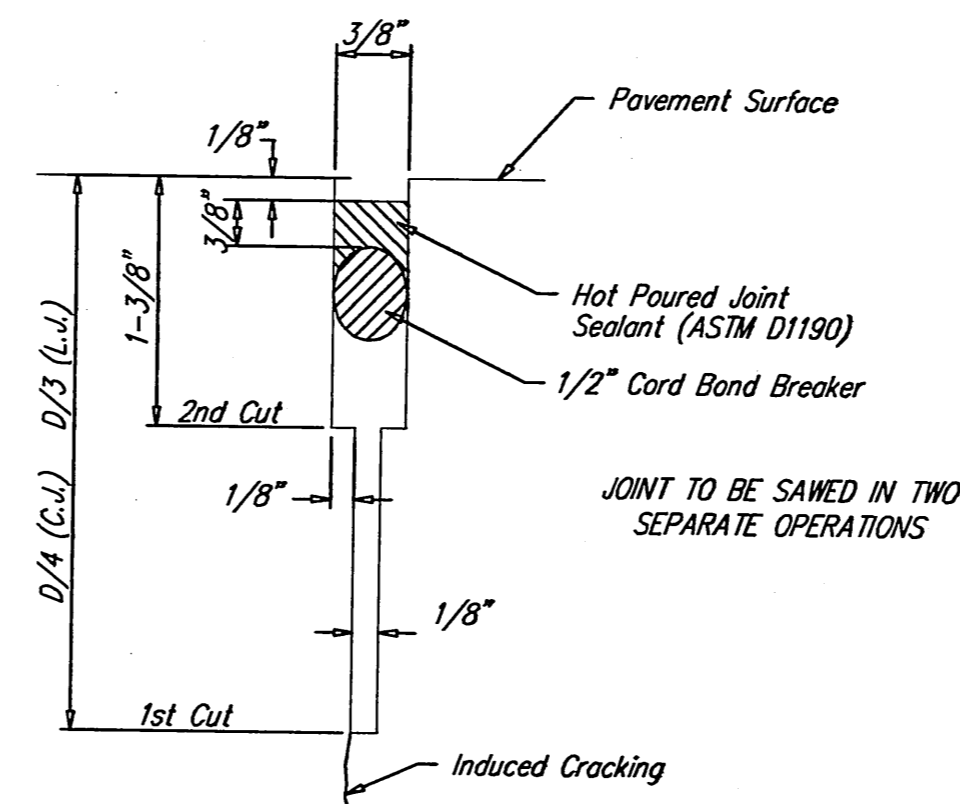

**SAW JOINT DETAIL**

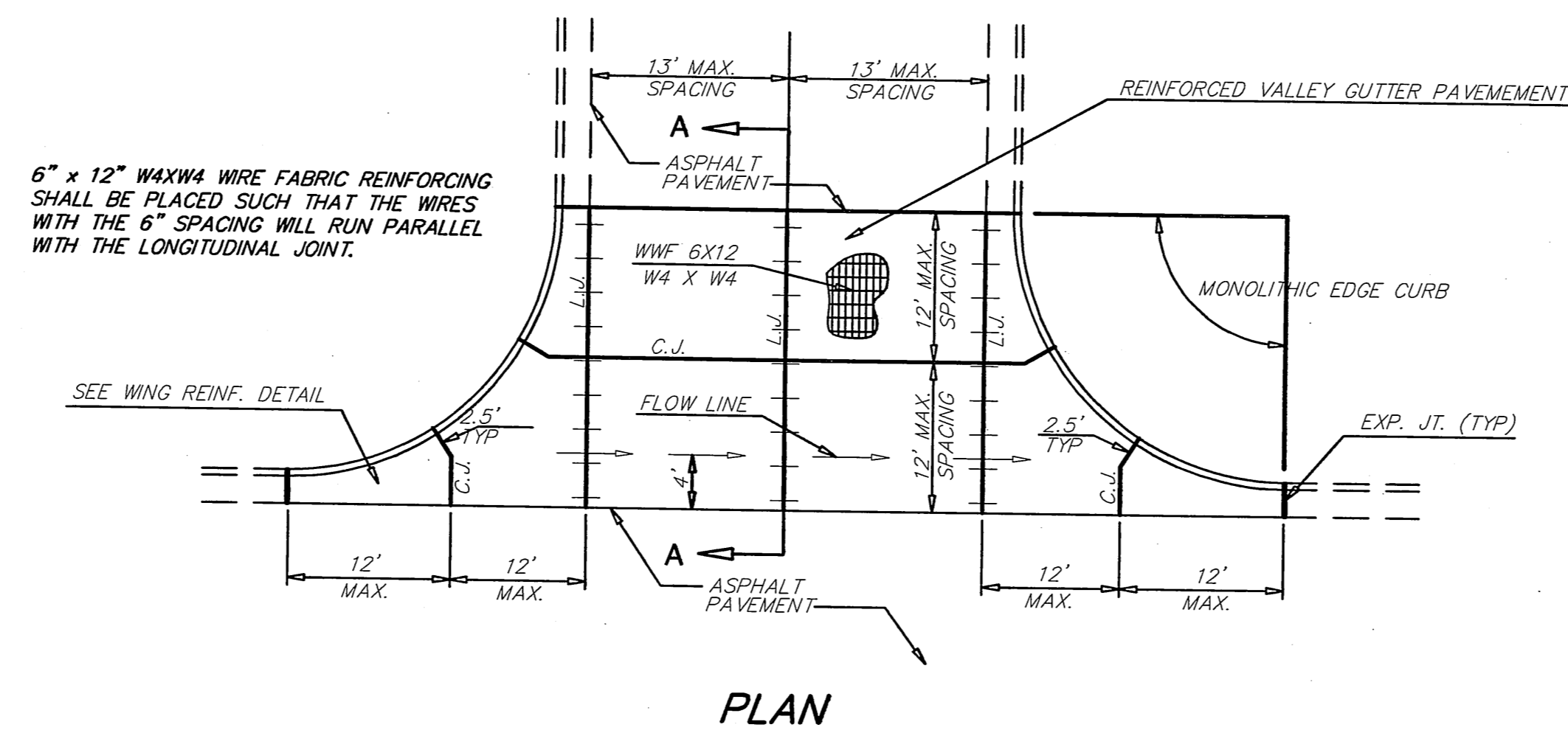

**PLAN**

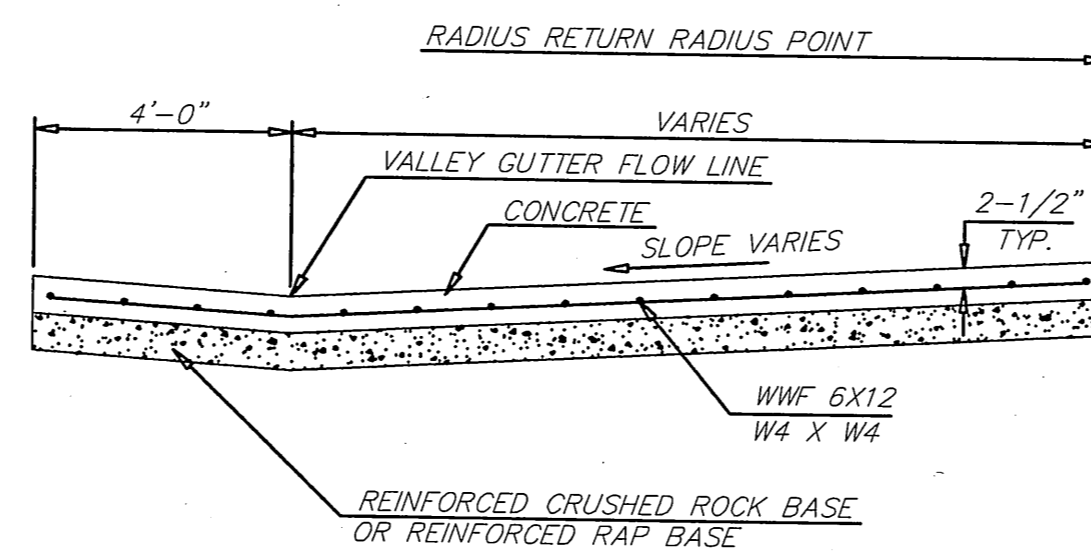

**SECTION A-A**

**REINFORCED VALLEY GUTTER DETAIL**

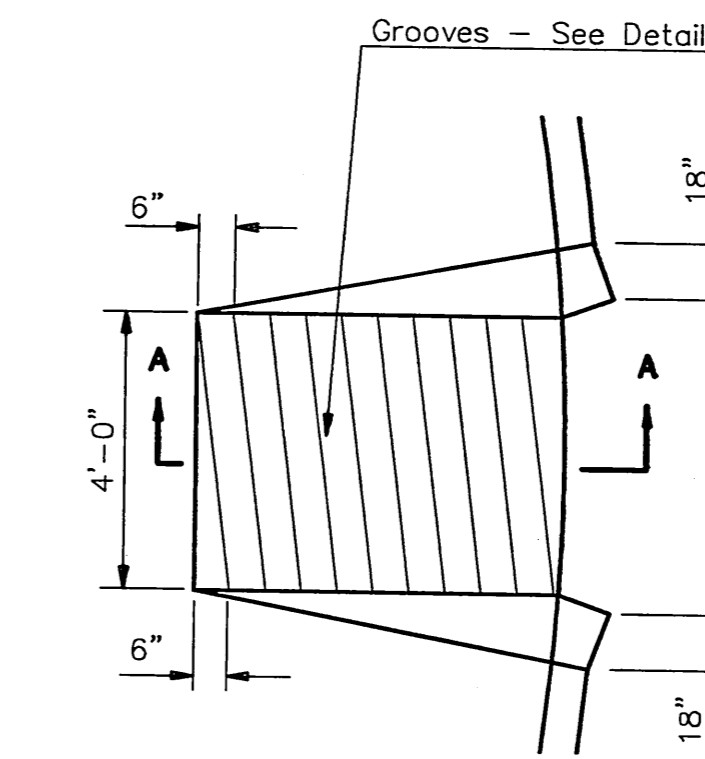

**WHEELCHAIR RAMP PLAN VIEW**

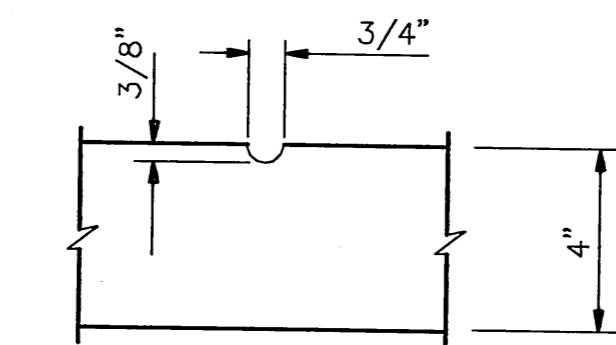

**GROOVE DETAIL**

**WHEELCHAIR RAMP DETAIL**

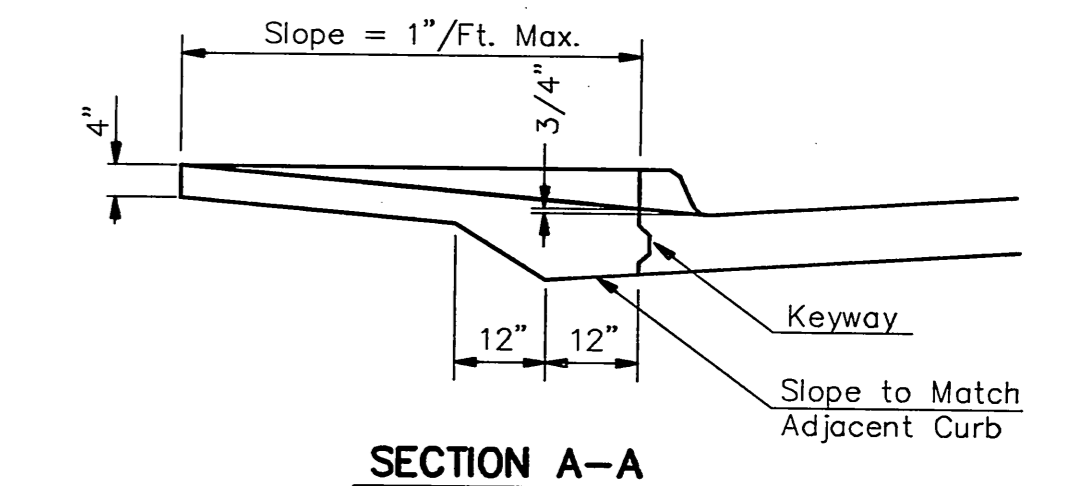

**SECTION A-A**

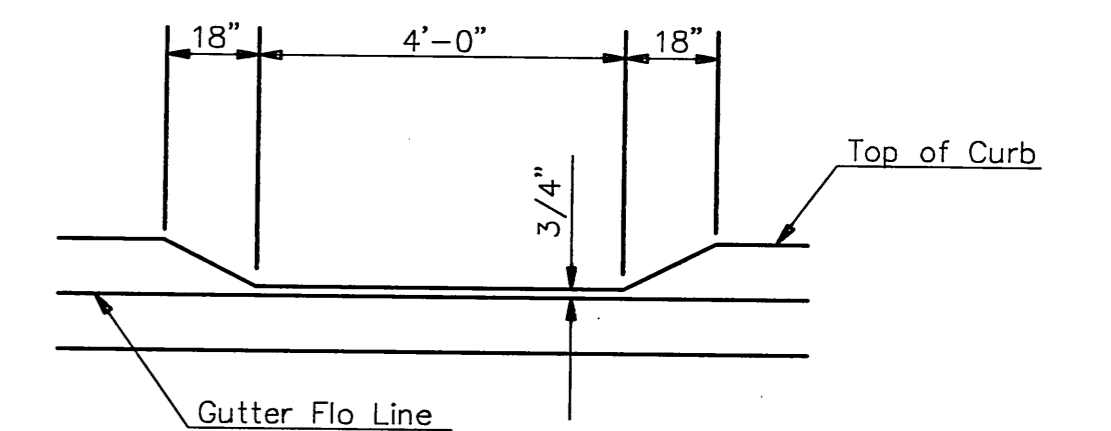

**DEPRESSED CURB DETAIL**

MOORINGS NORTH ADDITION

**VALLEY GUTTER DETAILS  
WHEELCHAIR RAMP  
DETAILS**

M. E. LINDEBAK P.E. - CITY ENGINEER

PROJECT NUMBER 468-82879	INDEX CODE 764654
-----------------------------	----------------------

DATE OCT 96	SHEET 43 OF 48
----------------	----------------