

**PLAN**

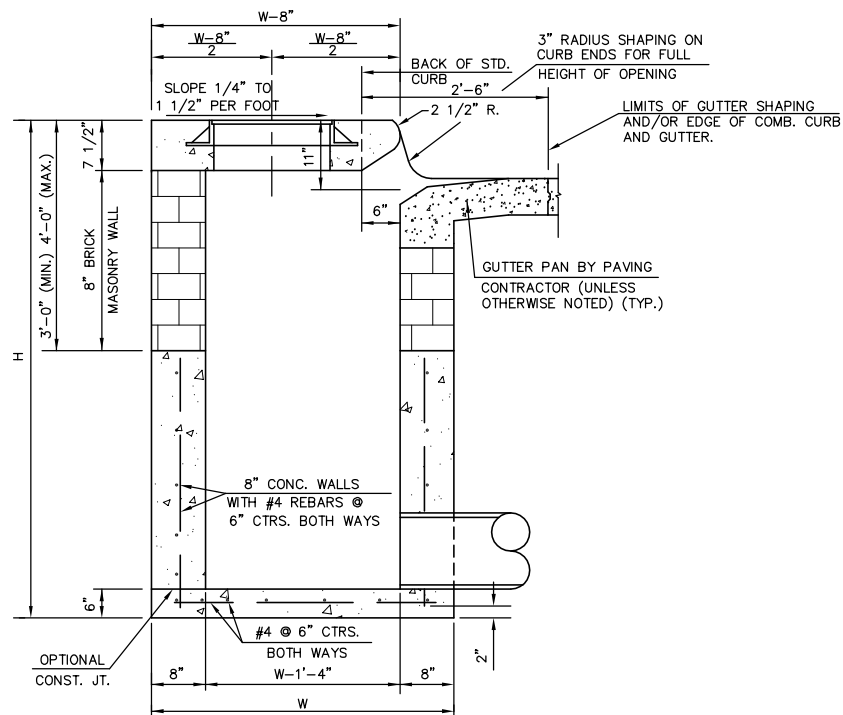

**SECTION A-A**

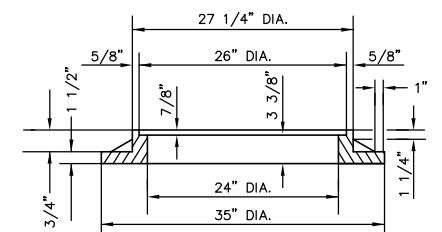
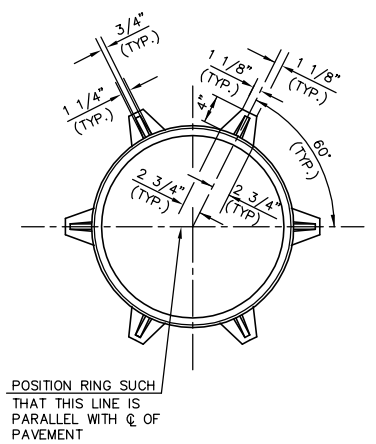

**INLET FRAME**

**GENERAL NOTES**

- CONCRETE SHALL BE C.O.W. STANDARD PAVING MIX. ALL EXPOSED EDGES SHALL BE FINISHED WITH AN EDGING TOOL. REINFORCING BARS SHALL BE FIELD BENT OR CUT TO CLEAR PIPES. ALL BARS ARE #4 BARS AT 6" SPACING AND SHALL HAVE A MINIMUM CLEARANCE OF 1 1/2" UNLESS OTHERWISE NOTED. FLOORS OF INLET SHALL BE SHAPED WITH 8.0 SACKS PER CU. YD. SAND MIX CONCRETE TO INCREASE HYDRAULIC EFFICIENCY SUCH THAT THE INLET WILL BE SELF CLEANING BETWEEN ALL INLET AND/OR OUTFALL PIPE(S). THE CONTRACTOR WILL BE REQUIRED TO CONSTRUCT 8" BRICK MASONRY WALLS BETWEEN THE CONCRETE INLET BASE AND TOP ON THIS INLET WHEN H= 7'-0" OR LESS AND W= 6'-4" OR LESS.
- THE ENDS OF ALL PIPES INSTALLED IN INLETS SHALL BE CUT OFF FLUSH WITH THE INSIDE FACE OF THE INLET WALL.

SEE CITY OF WICHITA STANDARD MANHOLE FRAME AND COVER DETAIL SHEET FOR COVER DETAILS TO BE USED WITH INLET FRAME.

**STEEL SCHEDULE**

MARK	SIZE	W=4'-4"		W=5'-4"		W=6'-4"		W=7'-4"		W=8'-4"	
		NO.	LENGTH	NO.	LENGTH	NO.	LENGTH	NO.	LENGTH	NO.	LENGTH
a1	#4	4	5'-7"	4	7'-7"	4	9'-7"	4	11'-7"	4	13'-7"
a2	#4	4	6'-7"	4	8'-7"	4	10'-7"	4	12'-7"	4	14'-7"
a3	#4	2	4'-0"	2	5'-0"	2	6'-0"	2	7'-0"	2	8'-0"
b1	#4	1	6'-1"	3	6'-1"	5	6'-1"	7	6'-1"	9	6'-1"
b2	#4	6	1'-9"	6	1'-9"	6	1'-9"	6	1'-9"	6	1'-9"
b3	#4	1	6'-2"	1	6'-2"	1	6'-2"	1	6'-2"	1	6'-2"
b4	#4	6	4'-8"	6	4'-8"	6	4'-8"	6	4'-8"	6	4'-8"
WEIGHT (LBS)		±60.0		±81.0		±101.0		±121.0		±141.0	

NOTE: a3 BARS TO BE PLACED APPROX. 2" BELOW TOP OF INLET COVER.

STANDARD CURB INLET PRECAST TOPS			
W	PRE-CAST TOP SIZE	PIPE SIZE	CU. YD. CONC.
4'-4"	3'-8"x6'-4"x7 1/2"	21" & SMALLER	± 0.38
5'-4"	4'-8"x6'-4"x7 1/2"	24" & 30"	± 0.51
6'-4"	5'-8"x6'-4"x7 1/2"	36" & 42"	± 0.64
7'-4"	6'-8"x6'-4"x7 1/2"	48" & 54"	± 0.77
8'-4"	7'-8"x6'-4"x7 1/2"	60" & 66"	± 0.90

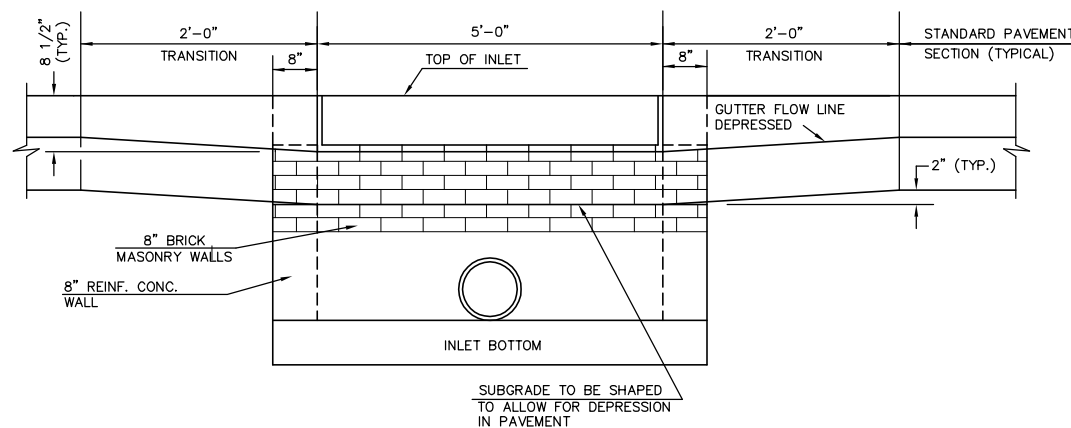
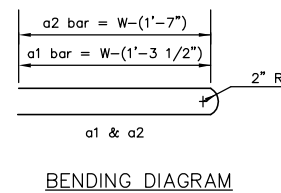

**SECTION C-C**

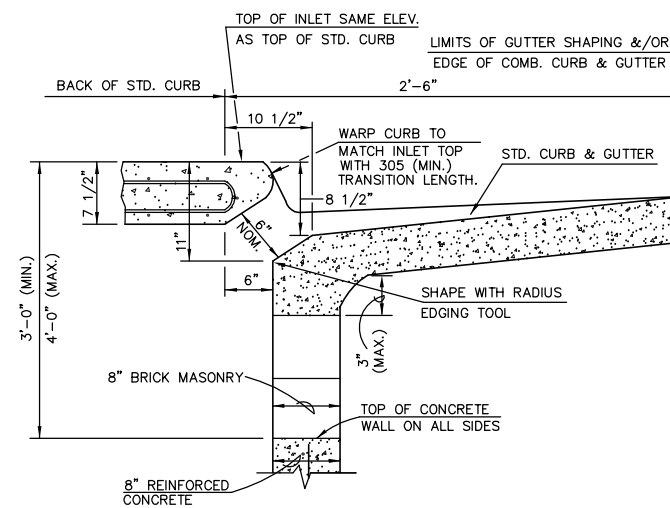

THE CITY OF WICHITA

CITY ENGINEER'S OFFICE  
CITY HALL - SEVENTH FLOOR  
455 NORTH MAIN STREET  
WICHITA, KANSAS 67202  
(316) 268-4501  
(316) 268-4114 FAX

**STANDARD TYPE 1  
CURB INLET**

**OPENING = 6" x 5'-0"**

NEIL D. CABLE, P.E. - CITY ENGINEER

PROJECT NUMBER	INDEX CODE
472-84362	XXXXXX
DATE	SHEET
MAR 96	18 OF 68