

**PLAN VIEW**  
Scale 1" = 8'

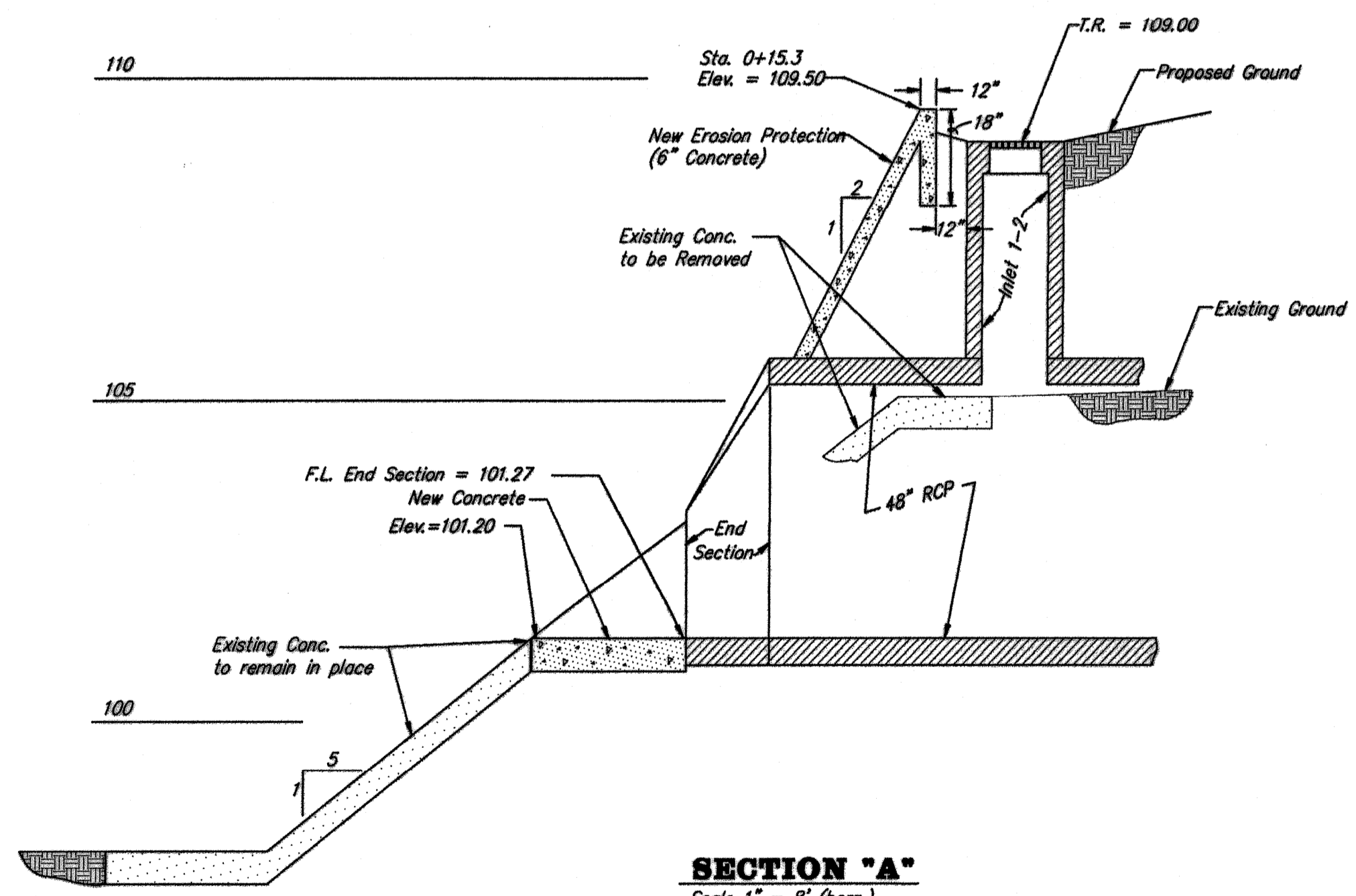

**SECTION "A"**  
Scale 1" = 8' (horz.)  
1" = 2' (vert.)

**END SECTION #1-1 DETAIL**

**INLET SCHEDULE**

INLET NUMBER	LENGTH "L"	WIDTH "W"
1-3	3.0'	6.0'
1-4	3.0'	6.0'
1-5	5.0'	6.0'

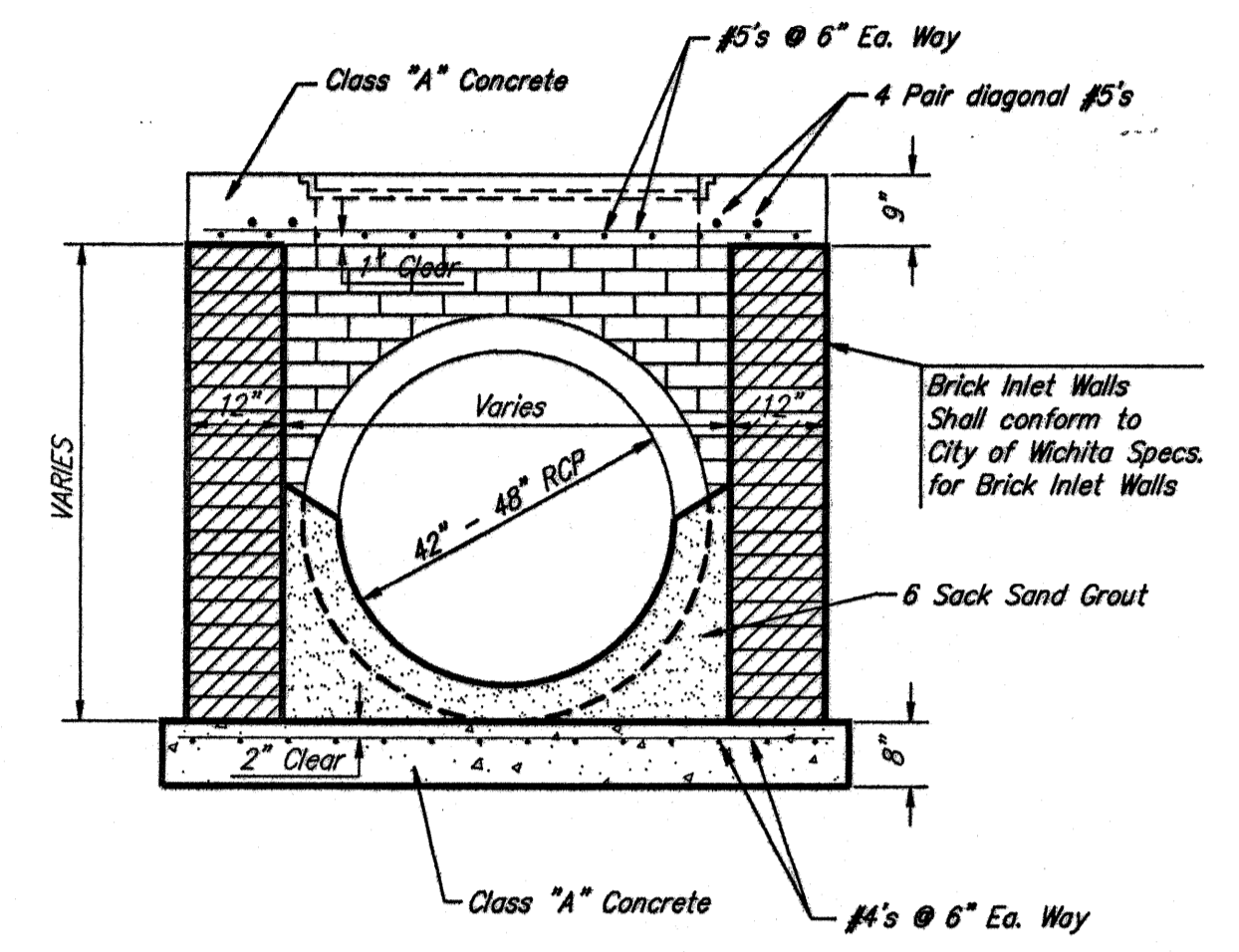

**TYPICAL SECTION**  
SCALE: 1/2"=1'-0"

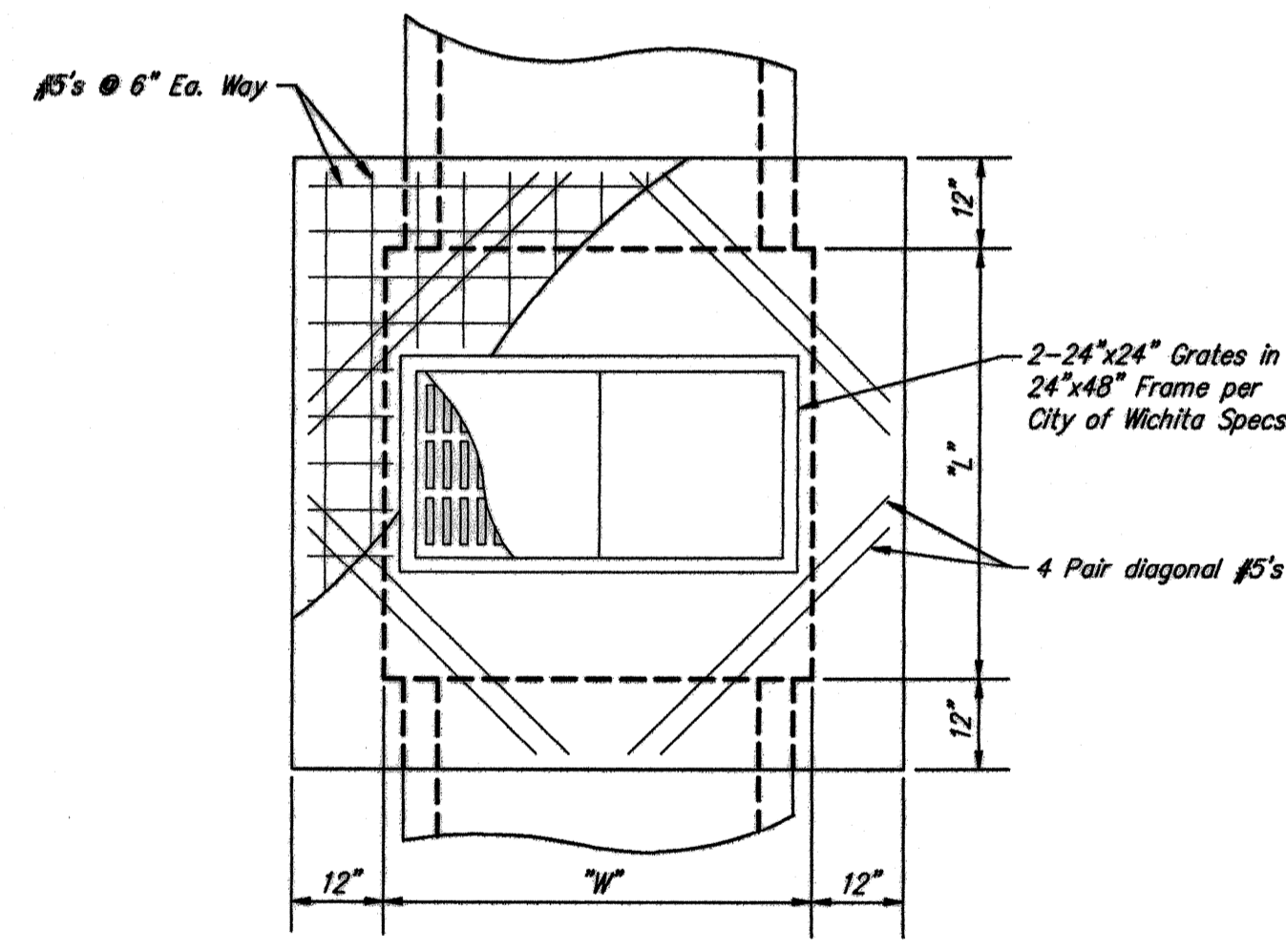

**PLAN VIEW TYPE "A" INLET**  
SCALE: 1/2"=1'-0"

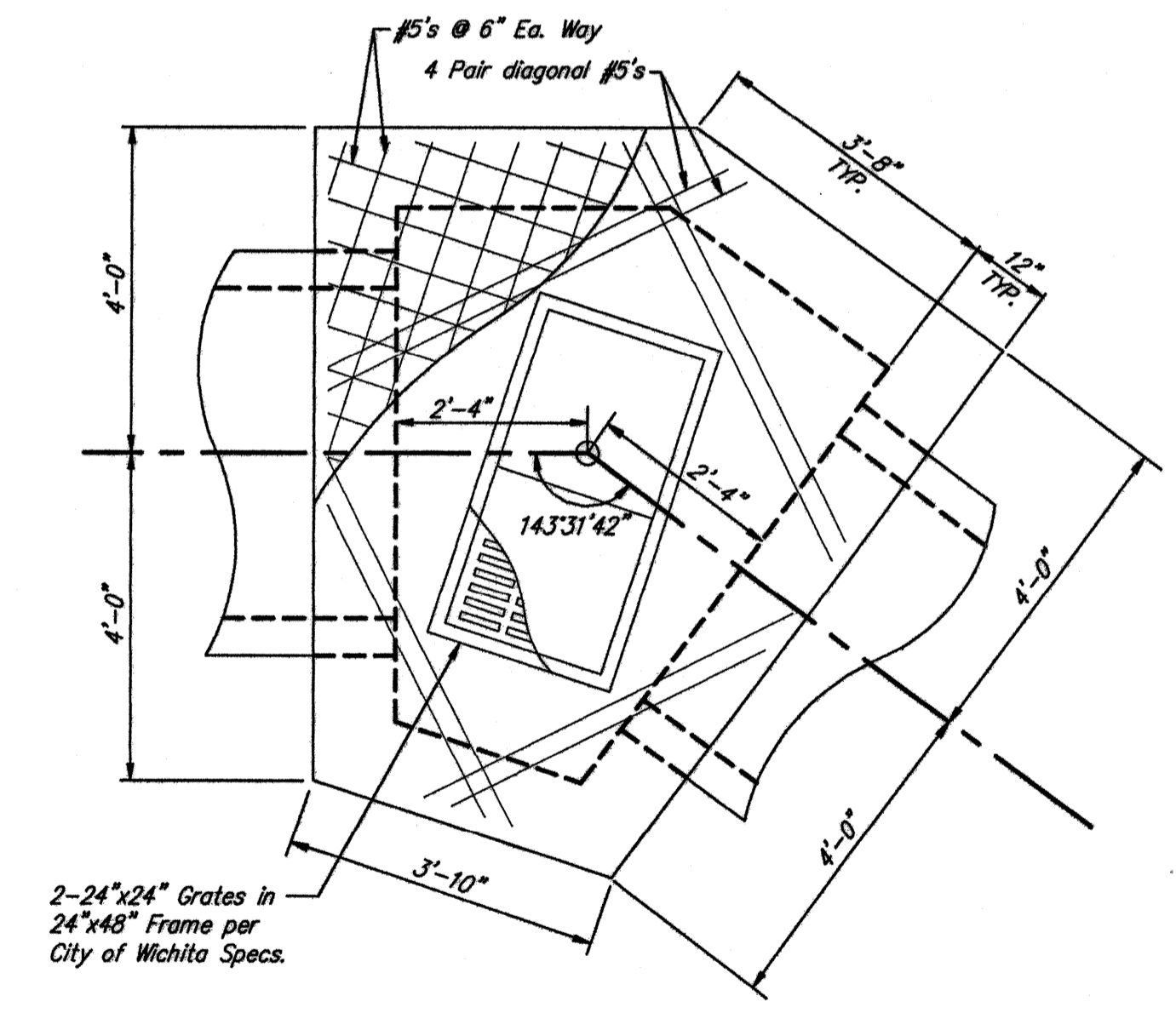

**PLAN VIEW TYPE "B" INLET**  
SCALE: 1/2"=1'-0"

**INLET DETAILS**

PRIVATE STORM WATER SEWER  
EXTENSION TO SERVE  
GOEBEL 4th ADDITION

**DETAIL SHEET**

City of Wichita Project No. 14533142

No.	Revision	By	Date
1			

BAUGHMAN COMPANY P. A.  
SURVEYING & ENGINEERING  
316/282-7271 • 315 ELLIS • WICHITA, KANSAS 67211

Drawn by: [Signature] Date: December 16, 1998 08/08